

Plastics Sorting
Mineral Analysis
Crystal Inspection
X-Ray Fluorescence
Plating Measurement
X-Ray Diffraction
Thickness Gauging
Cargo Screening
Food Inspection
NDT Analysis
Undersea Telecom
Security Applications
Radiography
Fluoroscopy
Extraoral Dental X-Ray
Bone Densitometry
Mammography
Mass Spectrometry
Capillary Electrophoresis
Electrostatic Printing
Ion Beam Implantation
Semiconductor Processing
Electron Beam Welding
Capacitor Charging
High Power RF Transmitters



Spellman High Voltage... Your Global Resource for High Voltage Power Conversion

MEETING CUSTOMER NEEDS

For 70 years, Spellman has been helping technology companies grow by providing standard and custom high voltage power converters and X-Ray generators of exceptional value and performance and by aligning our procedures, processes and infrastructure to support our customers' goals – a process we call homologation. At Spellman, homologation is in everything we do. From initial product concept through final delivery, we dedicate a team of experts to work with each customer.

YOUR VISION IS OUR MISSION

Spellman advances medical care, industrial processes, quality control, scientific research, security and telecommunications by providing innovative high voltage power conversion solutions that enable equipment manufacturers to improve their systems' performance, reliability, cost and bottom line.

■ **Innovation & Quality:**

With 70 years of high voltage innovation, world-class ISO certified production facilities and global support network, Spellman can meet the needs of discriminating global OEM's system manufacturers

■ **Compliance and Safety:**

Safety and Regulatory Agency approvals such as: UL, CSA, and IEC can be provided. In addition, Spellman is authorized to conduct UL sanctioned testing

■ **Risk Management:**

Consistent processes across multiple facilities ensures a secure supply chain. Products can be manufactured at multiple Spellman sites. With standardized manufacturing, training and equipment, you can be assured of quality products and service for years to come

■ **Support and Service:**

Our globally situated technical support centers are strategically located to provide rapid local response to customer needs. Support Centers are linked through a common ERP system and real-time data reporting so information is always available about your product and delivery status



spellmanhv.com



Spellman's MS Modules have been designed for printed circuit board mounting with high reliability, small size and light weight. Each module provides 3W of output power to 3kV with well regulated low ripple, high stability and high voltage in a versatile, compact cost-effective design. The modules incorporate remote control and arc & short-circuit protection. Radiated pickup is eliminated by sealing each module in an aluminum enclosure.

TYPICAL APPLICATIONS

Photomultiplier Tubes
Precision Lenses
Image Intensifiers
Nuclear Instruments
Spectroscopy

OPTIONS

I Isolated Input to Output
Isolation Voltage: 40V for units up to 1kV
100V for units >1kV

SPECIFICATIONS

Input Voltage:

+12Vdc \pm 1V. Other input voltages also available.

Input Current:

< 0.56A at full output.

Output Voltage:

Continuously adjustable over each entire range
Models available in either positive or negative polarity.
See table for voltage ranges.

- **Low Cost**
- **Output Voltages up to 3kV**
- **3 Watts Power Rating**
- **Positive or Negative Polarity**
- **Arc and Continuous Short Circuit Protected**
- **Low Stored Energy**
- **High Reliability**
- **Internal 5V Reference**
- **OEM Customization Available**

Line Regulation:

< 0.005% for input change of 1V

Load Regulation:

< 0.05% for 100 μ A to full load change. (at max. voltage)

Output Voltage Control:

Remote voltage programming such that 0-5Vdc gives 0 to full rated output

Output Power: 3W continuous.

Voltage Regulation:

Line: 0.005% for input change of 1V
Load: 0.05% for 100 μ A to full load change at maximum voltage.

Ripple: < 0.01% p-p of full output voltage.

5Vdc Reference: +5.0V (\pm 0.2V)

A maximum of 1mA can be drawn from this output.

Temperature:

Operating: 0°C to +50°C.
Storage: -35°C to +85°C.

Temperature Coefficient: 50ppm/°C typical.

Stability:

< 0.05%/8 hrs at constant operating conditions after one hour warm-up.

Humidity: 0 to 90% non-condensing.

Dimensions:

Up to 1000Vdc:
.87"H x 2.1"W x 3.1"D (23mm x 53mm x 78mm).
1000V to 3000Vdc:
1.1"H x 2.36"W x 4.2"D (28mm x 60mm x 106mm).

Weight:

Up to 1000V: 0.2lb (80g).
Over 1000V: 0.4lb (160g).

Regulatory Approvals:

Compliant to EEC EMC Directive. Compliant to EEC Low Voltage Directive. RoHS compliant.

MS SELECTION TABLE

OUTPUT VOLTAGE (V)	OUTPUT CURRENT (mA)	RIPPLE V (p-p)	MODEL
300	10	0.03	MS0.3*/C
500	6	0.05	MS0.5*/C
750	4	0.075	MS0.75*/C
1000	3	0.10	MS1*/C
1500	2	0.15	MS1.5*/C
2000	1.5	0.20	MS2*/C
2500	1.2	0.25	MS2.5*/C
3000	1	0.30	MS3*/C

*Specify "P" for positive polarity or "N" for negative polarity.

DIMENSIONS: in.[mm]

UNIT UP TO 1000V

SIDE VIEW

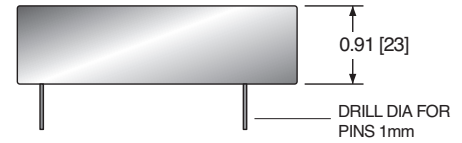

BOTTOM VIEW

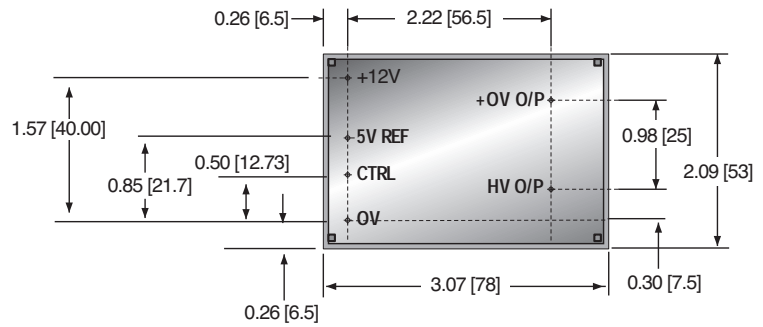

UNIT > 1000V UP TO 3000V

SIDE VIEW

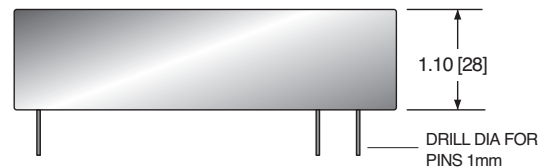

BOTTOM VIEW

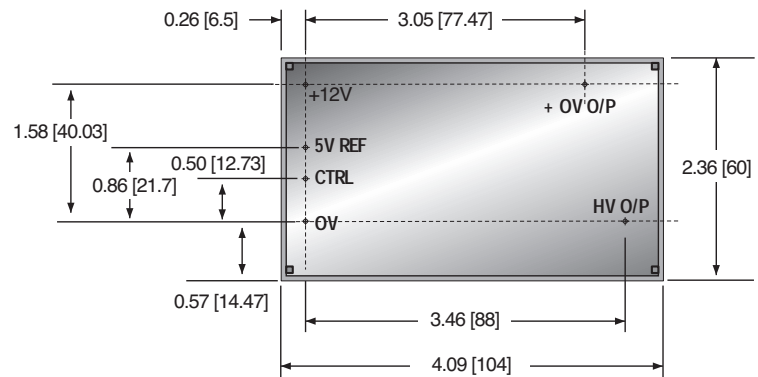

View on pins.
Recommended hole size
for terminals 1mm.





Spellman's Bertan brand of PMT modular high voltage power supplies offer well regulated, fixed polarity outputs up to 7.5kV, which operate off a low voltage DC input voltage. These fully enclosed modules are specifically designed with proprietary linear power conversion techniques to provide exceptionally low ripple and noise. The PMT is ideal for precision applications including: photomultiplier tubes, solid state detectors and ultrasonic transducers.

The output voltage can be controlled by either a local internal potentiometer or by a customer provided ground referenced signal for remote operation. Additionally a ground referenced output voltage monitor signal is provided. The PMT can be powered from either a single positive voltage source or a split \pm voltage source, providing application flexibility.

TYPICAL APPLICATIONS

Photomultiplier tubes
Ultrasonic transducers
Solid state detectors

SPECIFICATIONS

Input Voltage:

Option 1: +24Vdc to +30Vdc @ 400mA
Option 3: \pm 12Vdc to \pm 18Vdc @ 400mA
specify "-1" (option 1) or "-3" (option 3) when ordering

Efficiency:

\approx 50%, typical

Output Polarity:

Positive or negative, specify at time of order

Output Voltage:

See "model selection" table

Output Current:

See "model selection" table

Output Power:

1.875W, 2W, 2.5W, 3W, 4W

Voltage Regulation:

Line: \pm 0.001% of rated output voltage for a +1% input line change

Load: \pm 0.001% of rated output voltage for a full load change

- **500V to 7.5kV @ 1.9 to 4 Watts**
- **Low Cost Modular Design**
- **Excellent Stability & Regulation**
- **Low Noise & Ripple**
- **Arc & Short Circuit Protected**
- **UL Recognized and RoHS Compliant**

Ripple:

See "model selection" table

Stability:

\leq 0.005% per hour, 0.02% per 8 hours, after a 1/2 hour warm up

Accuracy:

Remote Programming \pm (2% of setting, +0.5% of maximum)
Voltage Monitor \pm 2%

Temperature Coefficient:

\leq 50ppm/ $^{\circ}$ C

Arc/Short Circuit:

All units are fully arc and short circuit protected and will limit continuous short circuit output current to less than 150% of maximum rated output current.

Operating Temperature

0 $^{\circ}$ C to +50 $^{\circ}$ C

Storage Temperature:

-40 $^{\circ}$ C to +85 $^{\circ}$ C

Humidity:

20% to 85% RH, non-condensing

Interface Connector:

12 position card edge connector, mate provided with unit

Output Connector:

A captive 24" (610mm) of RG-59B/U shielded cable, unterminated is provided

Cooling:

Convection cooled.

Dimensions:

3.875" W X 1.25" H X 6.3125" D (98mm x 32mm x 160mm)

Weight:

\leq 2.0 pounds (0.9kg)

Regulatory Approvals:

Designed to meet EEC EMC Directive. Compliant to EEC Low Voltage Directive. UL/CUL recognized File E148969. RoHS compliant.

MODEL SELECTION TABLE

Model	Output Voltage	Output Current	Ripple (Vpp)
PMT-05C-P,N	0 to 500V	0 to 8mA	5mV
PMT-10C-P,N	0 to 1kV	0 to 4mA	4mV
PMT-20C-P,N	0 to 2kV	0 to 2mA	2mV
PMT-30C-P,N	0 to 3kV	0 to 1mA	6mV
PMT-50C-P,N	0 to 5kV	0 to 0.5mA	10mV
PMT-75C-P,N	0 to 7.5kV	0 to 0.25mA	100mV

Specify "P" for positive polarity or "N" for negative polarity

INTERFACE CONNECTOR

Signal	Parameters	Option 1 Pin Number	Option 3 Pin Number
+ Power Input	+24Vdc to +30Vdc or +12Vdc to +18Vdc	3&4	3 & 4 & 5
- Power Input	-12Vdc to -18Vdc	n/a	2 & 6
Ground	Ground	1 & 12	1 & 12
Voltage Monitor	See Voltage Monitor Table	11	11
+9Vdc Reference	+9.0Vdc, 10mA maximum	10	10
Voltage Program Input	0 to 9Vdc = 0 to 100% rated output, 100kΩ Zin	8	8
Local Voltage Program	Internal program potentiometer wiper, 0 to 9Vdc	9	9

VOLTAGE MONITOR TABLE

Model	Signal Voltage	Signal Impedance
PMT-05C-P,N	0 to 5 volts	50k ohms
PMT-10C-P,N	0 to 1 volts	10k ohms
PMT-20C-P,N	0 to 2 volts	25k ohms
PMT-30C-P,N	0 to 3 volts	30k ohms
PMT-50C-P,N	0 to 5 volts	100k ohms
PMT-75C-P,N	0 to 7.5 volts	200k ohms

Note: The Voltage Monitor polarity matches the high voltage output polarity

DIMENSIONS: in.[mm]

TOP VIEW

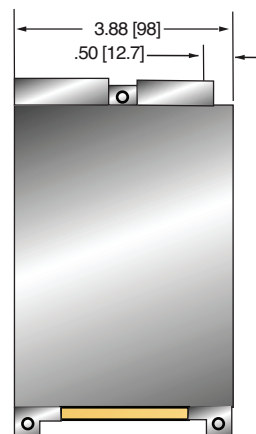

BOTTOM VIEW

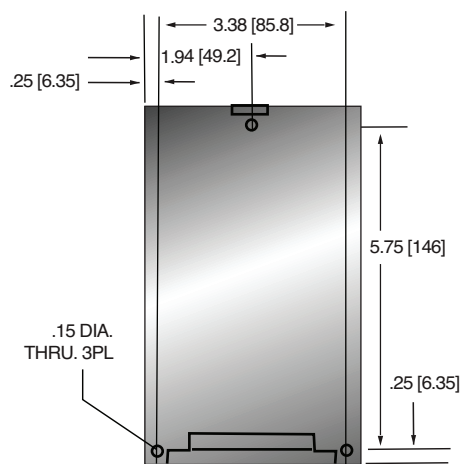

FRONT VIEW

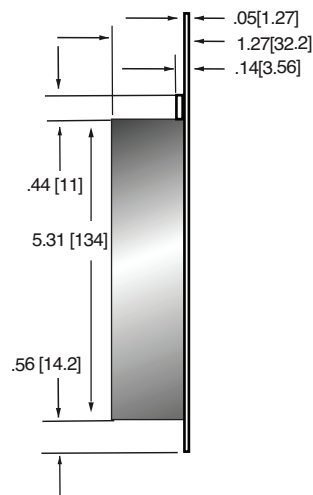



- **8 Voltage Ranges from 62.5V to 6kV, Fixed Negative or Positive Polarity**
- **Available Output Power Increments of 4, 20 and 30 Watts**
- **Voltage/Current Regulation with Automatic Crossover Control**
- **Voltage and Current Monitor Signals**
- **Fully Arc and Short Circuit Protected**
- **Precision +5V Reference Output**
- **Comprehensive Standard Interface**
- **CE Listed, UL Recognized and RoHS Compliant**

www.spellmanhv.com/manuals/UM

Form, Fit and Function Design:

Spellman's UM Series of printed circuit board mountable, high voltage modules offer a form, fit and function replacement for presently available commercially made units, while providing additional features and benefits at competitive pricing. Utilizing proprietary power conversion technology and Spellman's six decades of high voltage experience, these SMT based high voltage modules provide improved performance/reliability and easier system integration at a lower cost when compared to the competition.

Advanced Power Conversion Topology:

UM converters use a proprietary zero voltage switching power conversion topology providing exceptional efficiency and inherent low noise and ripple. Radiated emissions are reduced compared to conventional switching topologies, minimizing or even eliminating the need to shield the unit from adjacent circuitry.

The high voltage output is generated using a ferrite core high voltage step up transformer which feeds the output circuitry. Units at 1kV or higher utilize an arrangement of half wave Cockcroft-Walton voltage multiplier stages to obtain the specified high voltage output, while lower voltage units use a robust rectification and filter circuit.

Due to the fixed, high frequency conversion rate the output capacitance is small resulting in minimal stored energy. Through the use of generously rated surge limiting resistors and a fast acting current loop, all units are fully arc and short circuit protected.

Control and Regulation:

The actual output voltage generated is sampled via a high impedance divider to create a voltage feedback signal. A current feedback signal is created via a current sense resistor in the low end return of the high voltage output circuitry. These two accurate ground referenced feedback signals are used to precisely regulate and control the units in addition to external monitoring purposes.

Due to the UM's unique converter topology it can provide full current into low impedance loads or even a short circuit. Standard units limit at 103% of maximum rated output current.

Standard Interface:

The Spellman UM Series interface provides current programming capability and positive polarity, buffered, low output impedance voltage and current monitor signals (zero to +4.64Vdc equals zero to full scale rated). A voltage programming input is provided where 0 to +4.64Vdc equals 0 to 100% of rated voltage.

Current programmability allows the user to set where the unit will current limit, anywhere from 0 to 100% of maximum rated current. This feature is beneficial where less than full output current is desired, like in the case of protecting a sensitive load.

The buffered low impedance voltage and current monitor signals can drive external circuitry directly, while minimizing loading and pickup effects. These features save the user the expense and implementation of external interface buffering circuitry while improving overall signal integrity.

This standard interface is made available via a row of 13 pins with 0.1" pin spacing. A legacy interface (7 pins on a 0.2" spacing) that is compatible with presently available commercially made units can be provided by ordering the "L" option.

Mechanical and Environmental Considerations:

The UM Series are solid encapsulated, printed circuit board mountable, plastic cased converters measuring only 2.97" X 1.5" X 0.83" (75.4mm X 38.1mm X 21.1mm). All units are encapsulated using a silicon based potting material which is considerably lighter in weight than epoxy. Two isolated, non grounded 2-56 machine screws thread into the module to securely mount it to the printed circuit board, relieving any stress on the interface pins. Mounting plates, brackets and flanged mounting options are also available

Regulatory Approvals:

Compliant to EEC EMC Directive. Compliant to EEC Low Voltage Directive. UL/CUL recognized, File E227588. RoHS Compliant.

SPECIFICATIONS

Input Voltage:

12Vdc for 4W, 24Vdc for 20W and 30W

Nominal Voltage Range:

11Vdc to 30Vdc for 4W, 23Vdc to 30Vdc for 20W and 30W

Input Current: (typical)

Disabled: 30mA
 No load: 90mA
 Full load:
 4 watt units: 0.5A
 20 watt units: 1.0A
 30 watt units: 1.5A

Efficiency:

80-85%, typical

Voltage Regulation:

Line: <0.01%
 Load: <0.01%

Current Regulation:

Line: <0.01%
 Load: <0.01%

Stability:

0.01% per 8 hours, 0.02% per day after 30 min. warmup

Accuracy:

2% on all programming and monitoring, except I Sense 10%

Temperature Coefficient: (typical)

Standard: 100ppm/°C
 Optional: 25ppm/°C (T Option)

Environmental:

Temperature Range:
 Operating: 0°C to 65°C case temperature
 Storage: -55°C to 85°C, non operational
 Humidity:
 10% to 90%, non-condensing.

Cooling:

Convection cooled, typical. 30 watt units operating at full power might require additional cooling to maintain case temperature below 65°C. Methods may include: forced air cooling, use of heat sink or metal case, etc. It is the user's responsibility to maintain the case temperature below 65°C. Damage to the power supply due to inadequate cooling is considered misuse and repairs will not be covered under warranty.

Dimensions:

2.96" L X 1.49" W X 0.81" H
 (75.2mm X 37.9mm X 20.6mm)

Weight:

4 oz. (113g), typical

UM 4W SELECTION TABLE

Model Number	Output V	Output Current	Low Freq. Ripple %Vp-p @ 1Hz-1kHz	High Freq. Ripple %Vp-p @ 1kHz-1MHz	Output Capacitance	Arc Limiting Resistance	I Sense Scaling Full Scale Signal	High Voltage Divider Resistance
UM0.062*4	0 to 62.5V	64mA	0.030	0.028	8.8µF	1Ω	1.5V	0.5MΩ
UM0.125*4	0 to 125V	32mA	0.045	0.014	8.8µF	4.4Ω	2.75V	0.88MΩ
UM0.25*4	0 to 250V	16mA	0.034	0.017	2.2µF	20Ω	4.9V	1.50MΩ
UM0.5*4	0 to 500V	8mA	0.036	0.040	0.8µF	94Ω	10.1V	2.65MΩ
UM1*4	0 to 1KV	4mA	0.025	0.015	0.2µF	470Ω	10.75V	20MΩ
UM2*4	0 to 2kV	2mA	0.022	0.015	0.097µF	1.0KΩ	10.4V	30MΩ
UM4*4	0 to 4kV	1mA	0.019	0.017	0.012µF	9.4KΩ	11.1V	100MΩ
UM6*4	0 to 6kV	0.67mA	0.016	0.015	0.007µF	20KΩ	9.9V	150MΩ

UM 20W SELECTION TABLE

Model Number	Output V	Output Current	Low Freq. Ripple %Vp-p @ 1Hz-1kHz	High Freq. Ripple %Vp-p @ 1kHz-1MHz	Output Capacitance	Arc Limiting Resistance	I Sense Scaling Full Scale Signal	High Voltage Divider Resistance
UM0.062*20	0 to 62.5V	320mA	0.060	0.088	8.8µF	1Ω	330mV	0.5MΩ
UM0.125*20	0 to 125V	160mA	0.067	0.044	8.8µF	4.4Ω	675mV	0.88MΩ
UM0.25*20	0 to 250V	80mA	0.035	0.019	2.2µF	20Ω	1.135V	1.50MΩ
UM0.5*20	0 to 500V	40mA	0.041	0.040	0.8µF	94Ω	2.25V	2.65MΩ
UM1*20	0 to 1KV	20mA	0.039	0.095	0.2µF	470Ω	4.35V	20MΩ
UM2*20	0 to 2kV	10mA	0.026	0.016	0.097µF	1.0KΩ	6.6V	30MΩ
UM4*20	0 to 4kV	5mA	0.023	0.028	0.012µF	9.4KΩ	6.65V	100MΩ
UM6*20	0 to 6kV	3.3mA	0.017	0.018	0.007µF	20KΩ	6.74V	150MΩ

UM 30W SELECTION TABLE

Model Number	Output V	Output Current	Low Freq. Ripple %Vp-p @ 1Hz-1kHz	High Freq. Ripple %Vp-p @ 1kHz-1MHz	Output Capacitance	Arc Limiting Resistance	I Sense Scaling Full Scale Signal	High Voltage Divider Resistance
UM0.062*30	0 to 62.5V	480mA	0.075	0.112	8.8µF	1Ω	500mV	0.5MΩ
UM0.125*30	0 to 125V	240mA	0.075	0.056	8.8µF	4.4Ω	930mV	0.88MΩ
UM0.25*30	0 to 250V	120mA	0.055	0.031	2.2µF	20Ω	1.65V	1.50MΩ
UM0.5*30	0 to 500V	60mA	0.085	0.041	0.8µF	94Ω	3.4V	2.65MΩ
UM1*30	0 to 1KV	30mA	0.032	0.171	0.2µF	220Ω	6.5V	20MΩ
UM2*30	0 to 2kV	15mA	0.031	0.112	0.097µF	470Ω	9.85V	30MΩ
UM4*30	0 to 4kV	7.5mA	0.028	0.071	0.012µF	4.4KΩ	9.85V	100MΩ
UM6*30	0 to 6kV	5mA	0.020	0.051	0.007µF	9.4KΩ	10.0V	150MΩ

Note: Total ripple is the sum of the low frequency and high frequency ripple. Grayed text indicates Legacy interface signals.

STANDARD INTERFACE

PIN	SIGNAL	PARAMETERS
1	Power Ground Return	+12Vdc or +24Vdc power return/HV return
1A	Signature Resistor	Unique Identifying resistor connected to ground
2	+ Power Input	+12Vdc or +24Vdc power input
2A	N/C	
3	I Sense	See I Sense text and tables
3A	I Mon	0 to 4.64Vdc = 0 to 100% rated output. Zout < 10kΩ
4	Enable Input	Low (<0.7V, Isink@1mA)=HV OFF, High (open or >2V)=HV ON
4A	V Mon	0 to 4.64Vdc = 0 to 100% rated output. Zout < 10kΩ
5	Signal Ground	Signal Ground
5A	I Pgm	0 to 4.64Vdc = 0 to 100% rated output. Zin > 47kΩ Leave open for preset current limit @103% of rated output current
6	Remote Adjust	Positive Polarity Unit: 0 to +4.64VDC = 0 to 100% rated voltage, Zin > 1MΩ Negative Polarity Unit: +5VDC to 0.36V = 0 to 100% rated voltage, Zin > 100kΩ Leave open if pin 6A (VPgm) is used for programming
6A	V Pgm	0 to 4.64Vdc = 0 to 100% rated voltage. Zin > 100kΩ Leave open if pin 6 (remote adjust) is used for programming
7	+5V Reference Output	+5Vdc ±0.5%, 50ppm/°C. Zout =475Ω
8	HV Ground Return	HV Ground Return
9	E Out Monitor	10:1 ratio for models below 1kV, 100:1 ratio for models 1kV and above. Polarity of Voltage Monitor signal equals polarity of unit. Accuracy is ±2%, 100ppm/°C. Calibrated with DVM with 10MΩ input impedance
10	HV Output	HV Output
11	HV Output	HV Output

Grayed out signals are provided for backward legacy compatability and their use is not required

Power Ground Return, Signal Ground and HV Ground Return are connected internally. For best performance they should not be connected externally.

LEGACY INTERFACE (L OPTION)

PIN	SIGNAL	PARAMETERS
1	Power Ground Return	+12Vdc or +24Vdc power return/HV return
2	+ Power Input	+12Vdc or +24Vdc power input
3	I Sense	See I Sense text and tables for details
4	Enable Input	Low (<0.7V, Isink@1mA)=HV OFF, High (open or >2V)=HV ON
5	Signal Ground	Signal Ground
6	Remote Adjust	Positive Polarity Unit: 0 to +4.64VDC = 0 to 100% rated voltage, Zin > 1MΩ Negative Polarity Unit: +5VDC to 0.36V = 0 to 100% rated voltage, Zin > 100kΩ
7	+5V Reference Output	+5Vdc ±0.5%, 50ppm/°C. Zout =475Ω
8	HV Ground Return	HV Ground Return
9	E Out Monitor	10:1 ratio for models below 1kV, 100:1 ratio for models 1kV and above. Polarity of Voltage Monitor signal equals polarity of unit. Accuracy is ±2%, 100ppm/°C. Calibrated with DVM with 10MΩ input impedance
10	HV Output	HV Output
11	HV Output	HV Output

Power Ground Return, Signal Ground and HV Ground Return are connected internally. For best performance they should not be connected externally.

Standard Interface Connections

Seventeen (17) gold plated 0.025" (0.64mm) square pins suitable for direct PCB mounting. See mechanical drawing for location and spacing details.

Programming and Monitor Signals

Voltage and current programming is done via positive polarity, high input impedance, 0 to 4.64Vdc signals. Voltage and current monitors are positive polarity, buffered low output impedance 0 to 4.64Vdc signals.

I Mon

The I Mon signal is a true output current monitoring signal. All internal offsets due to feedback divider currents have been compensated for.

Signature Resistor

A unique identifying signature resistor for each type of unit is connected from Pin 1A to ground. Details if desired are available upon request.

Legacy Interface Connections

Eleven (11) gold plated 0.025" (0.64mm) square pins suitable for direct PCB mounting. See mechanical drawing for location and spacing details.

I Sense Signal

The I Sense signal polarity is opposite of the output polarity of the module. This signal is protected via a transorb and provided via a series connected 47k isolation resistor. Internal HV dividers create a small, linear offset voltage on the I sense signal that can be compensated for.

Adhesive Backed Heat Sink

UM modules are provided with an uninstalled top mounted adhesive backed heat sink. Label removal is not required if the customer elects to install and use the provided heat sink.

The UM's internal power dissipation causes a case temperature rise. If the case exceeds 65°C, the unit needs external cooling (fan or heat sink). Even if the case is below 65°C, it is prudent to keep it much lower. Like a semiconductor device; the hotter it is, the shorter the life. For every 10°C reduction of temperature the lifetime will be increased by a factor of ~2.35. The thermal resistance from internal circuitry to ambient is 8°C/watt without a heat sink (still air). This reduces to 6°C/watt with the heat sink.

Example:

Assuming ~80% efficiency for a 20 watt UM module, the 5 watts of internal power dissipation would create a 40°C rise. Using the heat sink there would be only a 30°C rise. Ultimately it is up to the user to determine what cooling method is applicable for their application, but the general recommendation is to keep the module as cool as possible.

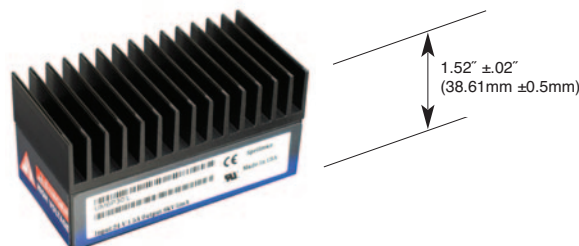

UM OPTIONS

C Option

Fast Rise Time Applications-

If applications demand a power supply that is optimized for fast rise time/low overshoot requirements, then the C Option should be considered. A Hysteretic control circuit is employed providing improved performance in these unique applications with higher ripple observed (1% Vpp typical). If used for capacitor charging, a Spellman Capacitor Charging Questionnaire should be filled out to assure all aspects of the intended usage is understood assuring the appropriate unit is provided. Speak to a Spellman sales person for more details.

T Option

Low Temperature Coefficient-

The T Option offers the UM with an improved temperature coefficient. The standard voltage feedback divider is replaced with one having a superior temperature coefficient, resulting in a unit with 25ppm/C° (typical) temperature coefficient.

Maximum short circuit discharge rate:

$$\frac{CV^2}{2} (f) < 1 \text{ watt}$$

- C = Output capacitance of unit
- C ext = External capacitance
- V = Maximum rated voltage
- f = Frequency of discharge
- I = Nominal output current
- t_R = Rise time

Typical Rise Time:

$$t_R = \frac{C + C_{ext}}{I} (V)$$

Minimum rise time is 3ms

PHYSICAL INTERFACING

A Option

Adapter Board-

Spellman's UM module can be fitted with an adapter board that will allow a drop in replacement for other commercially available modules of a physically larger size, while providing identical functionality with superior performance.

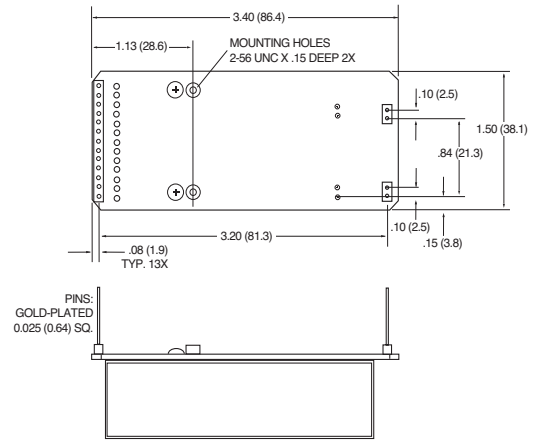
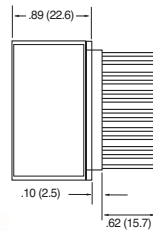

B Option

Terminal Block-

The B Option provides terminal block connections for both the customer interface and high voltage output/return. This feature can be helpful in situations where frequent wiring changes are anticipated, as in a testing or prototype environment.

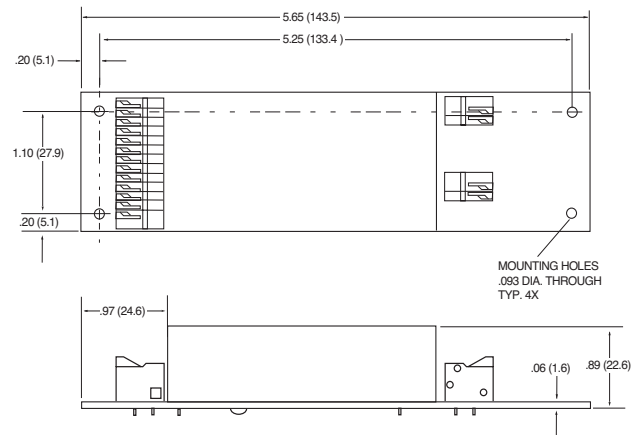
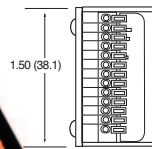

SHIELDING

M Option

Mu Metal Shield-

UM modules can be fitted with an adhesive backed Mu Metal foil shield to help protect sensitive adjacent circuitry.



Same as standard unit.
See page 6 of 6 for dimensional drawings

SHIELDING continued

S Option

RF Tight Shielded Can-

The S Option mounts the UM module inside of a flanged RF tight aluminum can.

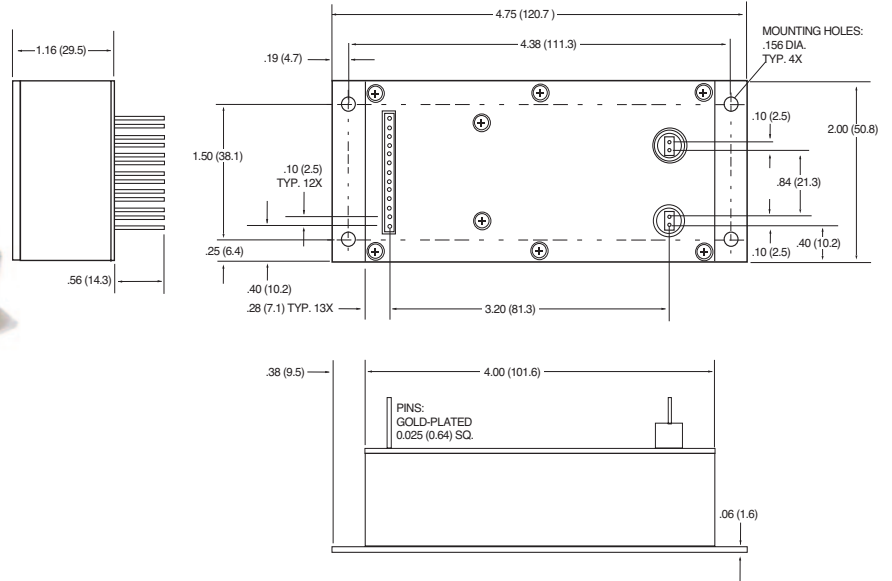

CHASSIS MOUNTING

E Option

Eared Mounting Plate-

An eared mounting plate is affixed to the top surface of the UM module allowing simple chassis mounting of unit.

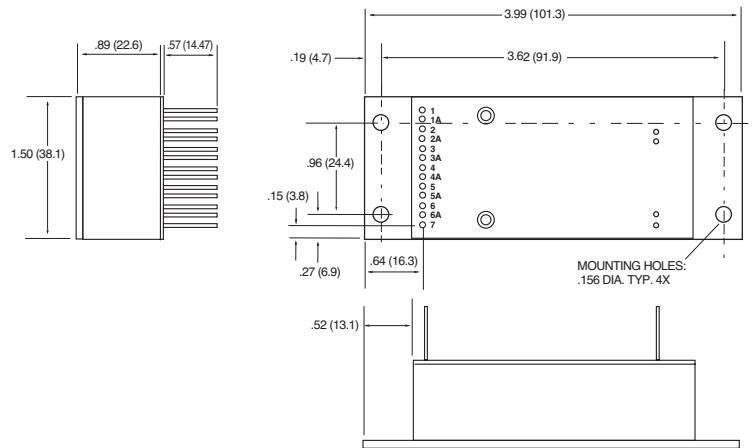
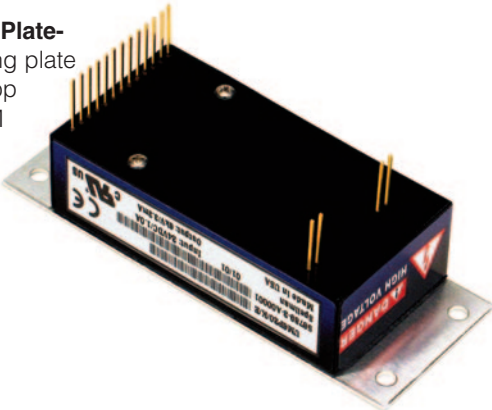

E2 Option

Eared Mounting Plate-

An eared mounting plate is affixed to the top surface of the UM module allowing simple chassis mounting of units ordered with the Adapter Board (A Option).

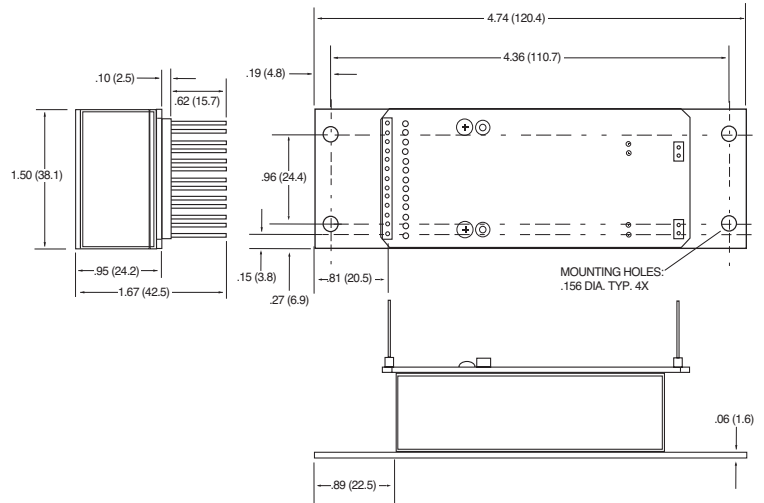
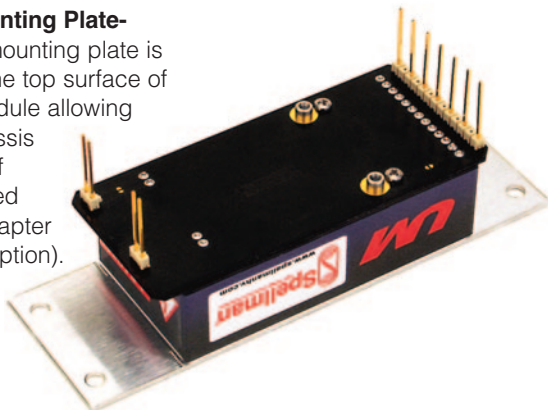

DIMENSIONS: in.[mm]

17 PIN - Standard Interface

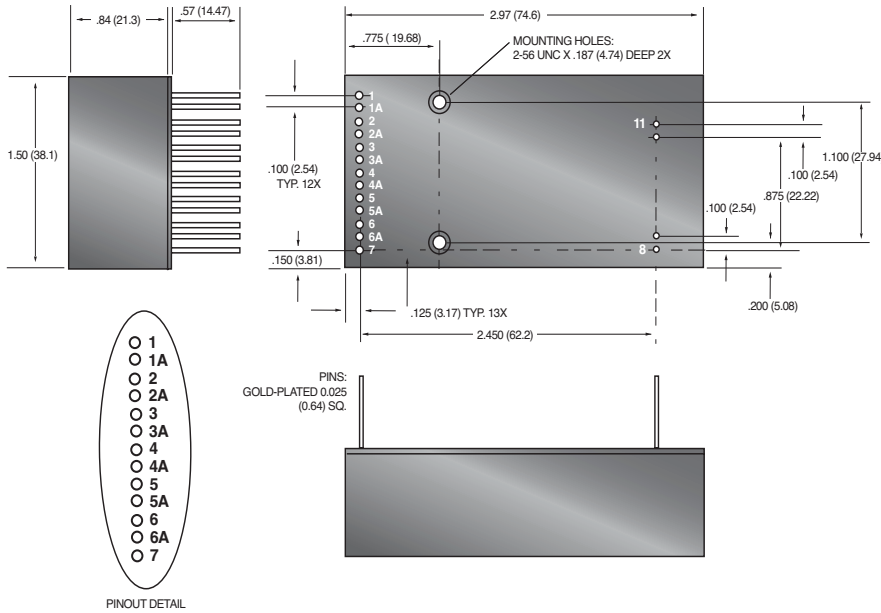

11 PIN - Legacy Interface

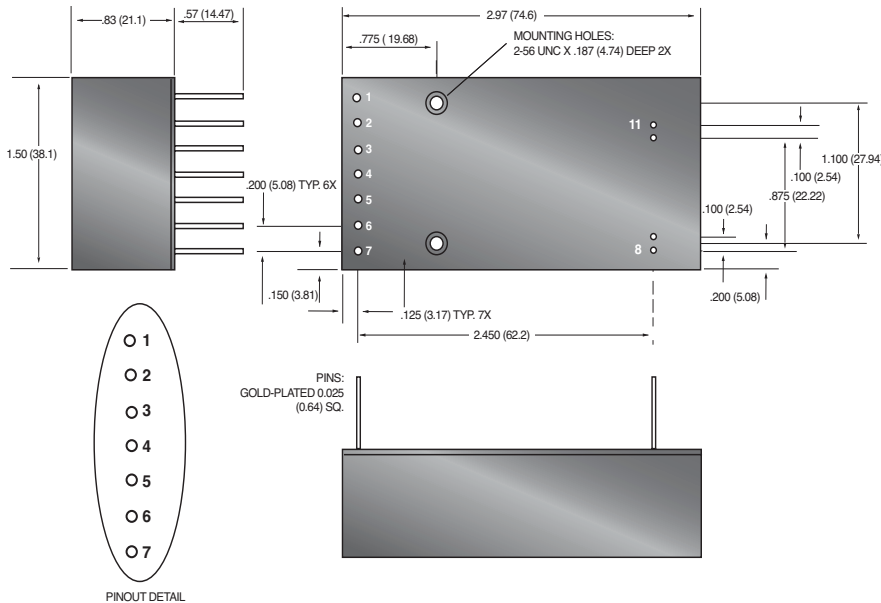

ORDERING INFORMATION

Voltage	0 to 62.5Vdc	0.062
	0 to 125Vdc	0.125
	0 to 250Vdc	0.25
	0 to 500Vdc	0.5
	0 to 1000Vdc	1
	0 to 2000Vdc	2
	0 to 4000Vdc	4
Polarity	Positive	P
	Negative	N
Power	Watts Output	4
	Watts Output	20
	Watts Output	30

STANDARD UNIT ORDERING EXAMPLE

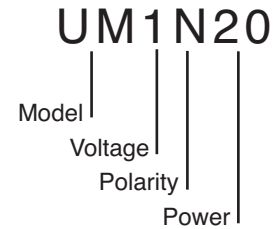

OPTION ORDERING INFORMATION

OPTION	OPTION CODE
Legacy Interface	L
Fast Rise Time	C
Low Temperature Coefficient	T
Adapter Board	A
Terminal Block	B
Mu Metal Shield	M
RF Tight Shielded Can	S
Eared Mounting Plate	E
Eared Mounting Plate/Adapter Board	E2

OPTION ORDERING EXAMPLE

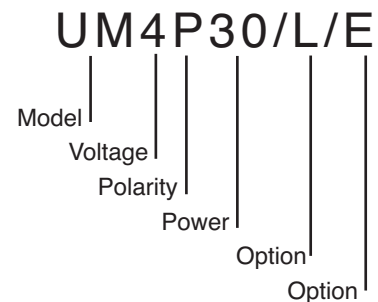

Note: There may be some restrictions on multiple option combinations. Please contact our sales department for more details.





- **9 Voltage Ranges from 8kV to 40kV, Fixed Negative or Positive Polarity**
- **Available Output Power Increments of 4, 15 and 30 Watts**
- **Voltage/Current Regulation with Automatic Crossover Control**
- **Voltage and Current Monitor Signals**
- **Fully Arc and Short Circuit Protected**
- **Precision +5V Reference Output**
- **Comprehensive Standard Interface**
- **CE listed and RoHS compliant**

www.spellmanhv.com/manuals/UM8-40

Form, Fit and Function Design:

Spellman's UM Series of printed circuit board mountable, high voltage modules offer a form, fit and function replacement for presently available commercially made units, while providing additional features and benefits at competitive pricing. Utilizing proprietary power conversion technology and Spellman's six decades of high voltage experience, these SMT based high voltage modules provide improved performance/reliability and easier system integration at a lower cost when compared to the competition.

Advanced Power Conversion Topology:

UM converters use a proprietary zero voltage switching power conversion topology providing exceptional efficiency and inherent low noise and ripple. Radiated emissions are reduced compared to conventional switching topologies, minimizing or even eliminating the need to shield the unit from adjacent circuitry.

The high voltage output is generated using a ferrite core high voltage step up transformer which feeds a half wave Cockcroft-Walton voltage multiplier to obtain the specified high voltage output.

Due to the fixed, high frequency conversion rate the output capacitance is small resulting in minimal stored energy. Through the use of generously rated surge limiting resistors and a fast acting current loop, all units are fully arc and short circuit protected.

Control and Regulation:

The actual output voltage generated is sampled via a high impedance divider to create a voltage feedback signal. A current feedback signal is created via a current sense resistor in the low end return of the high voltage output circuitry. These two accurate ground referenced feedback signals are used to precisely regulate and control the units in addition to external monitoring purposes.

Due to the UM's unique converter topology it can provide full current into low impedance loads or even a short circuit. Standard units limit at 103% of maximum rated output current.

Standard Interface:

The Spellman UM Series interface provides current programming capability and positive polarity, buffered, low output impedance voltage and current monitor signals (zero to +4.64Vdc equals zero to full scale rated). A voltage programming input is provided where 0 to +4.64Vdc equals 0 to 100% of rated voltage.

Current programmability allows the user to set where the unit will current limit, anywhere from 0 to 100% of maximum rated current. This feature is beneficial where less than full output current is desired, like in the case of protecting a sensitive load.

The buffered low impedance voltage and current monitor signals can drive external circuitry directly, while minimizing loading and pickup effects. These features save the user the expense and implementation of external interface buffering circuitry while improving overall signal integrity.

This standard interface is made available via a row of 13 pins with 0.1" pin spacing. A legacy interface (7 pins on a 0.2" spacing) that is compatible with presently available commercially made units can be provided by ordering the "L" option.

Mechanical and Environmental Considerations:

The UM Series are solid encapsulated, printed circuit board mountable, plastic cased converters. All units are encapsulated using a silicon based potting material which is considerably lighter in weight than epoxy. Isolated, non grounded 2-56 machine screws thread into the module to securely mount it to the printed circuit board, relieving any stress on the interface pins. Mounting plates, brackets and flanged mounting options are also available. High voltage output is provided via a 36" (914.4mm) minimum length of appropriately rated high voltage wire.

Regulatory Approvals:

Compliant to EEC EMC Directive. Compliant to EEC Low Voltage Directive. UL/CUL recognized, File E227588. RoHS Compliant.

SPECIFICATIONS

Input Voltage:

12Vdc for 4W, 24Vdc for 15W and 30W

Nominal Voltage Range:

11Vdc to 30Vdc for 4W, 23Vdc to 30Vdc for 15W and 30W
 4W units can operate at 24Vdc input with no deratings or damage to unit

Input Current: (typical)

Disabled: 10mA @ 24Vdc
 Full output, no load: 160mA @ 24Vdc, 300mA @ 12Vdc
 Full output, full load:
 4 watt units: 330mA @ 24Vdc, 640mA @ 12Vdc
 15 watt units: 850mA @ 24Vdc
 30 watt units: 1590mA @ 24Vdc

Voltage Regulation:

Line: <0.01% Load: <0.01%

Current Regulation:

Line: <0.01% Load: <0.01%

Stability:

0.01% per 8 hours, 0.02% per day after 30 min. warmup

Accuracy:

2% on all programming and monitoring, except I Sense 10%

Temperature Coefficient: (typical)

Standard: 100ppm/°C
 Optional: 25ppm/°C (T Option)

Environmental:

Temperature Range:
 Operating: -40°C to 65°C case temperature
 Storage: -55°C to 105°C, non operational
 Humidity:
 10% to 90%, non-condensing.

Cooling:

Convection cooled, typical. 30 watt units operating at full power might require additional cooling to maintain case temperature below 65°C. Methods may include: forced air cooling, use of heat sink or metal case, etc. It is the user's responsibility to maintain the case temperature below 65°C. Damage to the power supply due to inadequate cooling is considered misuse and repairs will not be covered under warranty.

Dimensions:

8kV-12kV:
 3.700" L X 1.500" W X 0.990" H (93.98mm X 38.10mm X 25.03mm)
 15kV-20kV:
 4.700" L X 1.500" W X 0.990" H (119.38mm X 38.10mm X 25.03mm)
 25kV-40kV:
 6.960" L X 1.600" W X 1.14" H (176.78mm X 40.84mm X 28.87mm)

Weight:

8kV-12kV: 5.7 ounces (162 grams), typical
 15kV-20kV: 7.2 ounces (204 grams), typical
 25kV-40kV: 13.1 ounces (371 grams), typical

Output Cable:

UM8, UM10, UM12, UM15: TV20 (min. length, 36" (914.4mm)
 UM20, UM25: TV30 (min. length, 36" (914.4mm)
 UM30, UM35, UM40: TV40 (min. length, 36" (914.4mm)

UM 4W, 8kV TO 40kV SELECTION TABLE

Model Number	Output V	Output Current	Ripple(max) %Vp-p	Output Capacitance	Arc Limiting Resistance	I Sense Scaling Full Scale Signal	High Voltage Divider Resistance
UM8*4	0 to 8kV	0.5mA	0.05	6830pF	50kΩ	5V	200MΩ
UM10*4	0 to 10kV	0.4mA	0.05	4380pF	50kΩ	2.4V	300MΩ
UM12*4	0 to 12kV	0.333mA	0.05	4380pF	50kΩ	3.33V	300MΩ
UM15*4	0 to 15kV	0.266mA	0.05	3220pF	100kΩ	1.69V	400MΩ
UM20*4	0 to 20kV	0.2mA	0.05	2310pF	100kΩ	1.316V	550MΩ
UM25*4	0 to 25kV	0.16mA	0.05	1540pF	100kΩ	1.1V	800MΩ
UM30*4	0 to 30kV	0.133mA	0.05	1370pF	120kΩ	0.95V	900MΩ
UM35*4	0 to 35kV	0.115mA	0.05	1370pF	140kΩ	0.72V	900MΩ
UM40*4	0 to 40kV	0.1mA	0.05	1370pF	140kΩ	1.3V	900MΩ

UM 15W, 8kV TO 40kV SELECTION TABLE

Model Number	Output V	Output Current	Ripple(max) %Vp-p	Output Capacitance	Arc Limiting Resistance	I Sense Scaling Full Scale Signal	High Voltage Divider Resistance
UM8*15	0 to 8kV	1.875mA	0.05	6830pF	50kΩ	3.75V	200MΩ
UM10*15	0 to 10kV	1.5mA	0.05	4380pF	50kΩ	8.152V	300MΩ
UM12*15	0 to 12kV	1.25mA	0.05	4380pF	50kΩ	5V	300MΩ
UM15*15	0 to 15kV	1mA	0.05	3220pF	100kΩ	5.53V	400MΩ
UM20*15	0 to 20kV	0.75mA	0.05	2310pF	100kΩ	4.21V	550MΩ
UM25*15	0 to 25kV	0.6mA	0.05	1540pF	100kΩ	3.42V	800MΩ
UM30*15	0 to 30kV	0.5mA	0.05	1370pF	120kΩ	2.89V	900MΩ
UM35*15	0 to 35kV	0.429mA	0.05	1370pF	140kΩ	2.39V	900MΩ
UM40*15	0 to 40kV	0.375mA	0.05	1370pF	140kΩ	4.21V	900MΩ

UM 30W, 8kV TO 40kV SELECTION TABLE

Model Number	Output V	Output Current	Ripple(max) %Vp-p	Output Capacitance	Arc Limiting Resistance	I Sense Scaling Full Scale Signal	High Voltage Divider Resistance
UM8*30	0 to 8kV	3.75mA	0.05	6830pF	50kΩ	5.36V	200MΩ
UM10*30	0 to 10kV	3mA	0.05	4380pF	50kΩ	7.87V	300MΩ
UM12*30	0 to 12kV	2.5mA	0.05	4380pF	50kΩ	5V	300MΩ
UM15*30	0 to 15kV	2mA	0.06	3220pF	100kΩ	5.29V	400MΩ
UM20*30	0 to 20kV	1.5mA	0.06	2310pF	100kΩ	8.15V	550MΩ
UM25*30	0 to 25kV	1.2mA	0.06	1540pF	100kΩ	6.56V	800MΩ
UM30*30	0 to 30kV	1mA	0.06	1370pF	120kΩ	5.52V	900MΩ
UM35*30	0 to 35kV	0.857mA	0.05	1370pF	140kΩ	4.66V	900MΩ
UM40*30	0 to 40kV	0.75mA	0.05	1370pF	140kΩ	8.15V	900MΩ

Grayed text indicates Legacy interface signals.



Corporate Headquarters
 Hauppauge, New York USA
 +1-631-630-3000 FAX: +1-631-435-1620
 e-mail: sales@spellmanhv.com

www.spellmanhv.com

128074-001 REV. M

Spellman High Voltage is an ISO 9001:2008 and ISO 14001:2004 registered company

Copyright © 2010 Spellman High Voltage Electronics Corp.

STANDARD INTERFACE

PIN	SIGNAL	PARAMETERS
1	Power Ground Return	+12Vdc or +24Vdc power return/HV return
1A	Signature Resistor	Unique Identifying resistor connected to ground
2	+ Power Input	+12Vdc or +24Vdc power input
2A	OT Output	+5Vdc @ 1mA = Over Temp fault
3	I Sense	See I Sense text and tables for details
3A	I Mon	0 to 4.64Vdc = 0 to 100% rated output. Zout < 10kΩ
4	Enable Input	Low (<0.7V, Isink@1mA)=HV OFF, High (open or >2V)=HV ON
4A	V Mon	0 to 4.64Vdc = 0 to 100% rated output. Zout < 10kΩ
5	Signal Ground	Signal Ground
5A	I Pgm	0 to 4.64Vdc = 0 to 100% rated output. Zin > 47kΩ Leave open for preset current limit @103% of rated output current
6	Remote Adjust	Positive Polarity Unit: 0 to +4.64VDC = 0 to 100% rated voltage, Zin > 1MΩ Negative Polarity Unit: +5VDC to 0.36V = 0 to 100% rated voltage, Zin > 100kΩ Leave open if pin 6A (VPgm) is used for programming
6A	V Pgm	0 to 4.64Vdc = 0 to 100% rated voltage. Zin > 100kΩ Leave open if pin 6 (remote adjust) is used for programming
7	+5V Reference Output	+5Vdc ±1%, 25ppm/°C. Zout =475Ω
8	HV Ground Return	HV Ground Return
9	E Out Monitor	1000:1 ratio. Polarity of Voltage Monitor signal equals polarity of unit. Accuracy is ±2%, 100ppm/°C. Calibrated with DVM with 10MΩ input impedance

Grayed out signals are provided for backward legacy compatibility and their use is not required.

Power Ground Return, Signal Ground and HV Ground Return are connected internally. For best performance they should not be connected externally.

LEGACY INTERFACE (L OPTION)

PIN	SIGNAL	PARAMETERS
1	Power Ground Return	+12Vdc or +24Vdc power return
2	+ Power Input	+12Vdc or +24Vdc power input
3	I Sense	See I Sense text and tables for details
4	Enable Input	Low (<0.7V, Isink@1mA)=HV OFF, High (open or >2V)=HV ON
5	Signal Ground	Signal Ground
6	Remote Adjust	Positive Polarity Unit: 0 to +4.64VDC = 0 to 100% rated voltage, Zin > 1MΩ Negative Polarity Unit: +5VDC to 0.36V = 0 to 100% rated voltage, Zin > 100kΩ
7	+5V Reference Output	+5Vdc ±1%, 25ppm/°C. Zout =475Ω
8	HV Ground Return	HV Ground Return
9	E Out Monitor	1000:1 ratio. Polarity of Voltage Monitor signal equals polarity of unit. Accuracy is ±2%, 100ppm/°C. Calibrated with DVM with 10MΩ input impedance

Power Ground Return, Signal Ground and HV Ground Return are connected internally. For best performance they should not be connected externally.

Standard Interface Connections

Fifteen (15) gold plated 0.025" (0.64mm) square pins suitable for direct PCB mounting.

Legacy Interface Connections

Nine (9) gold plated 0.025" (0.64mm) square pins suitable for direct PCB mounting.

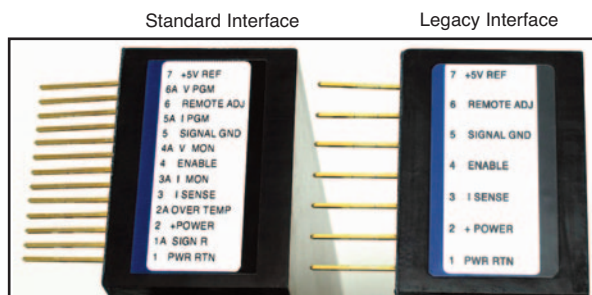

See mechanical drawing for location and spacing details

Programming and Monitor Signals

Voltage and current programming is done via positive polarity, high input impedance, 0 to 4.64Vdc signals. Voltage and current monitors are positive polarity, buffered low output impedance 0 to 4.64Vdc signals.

I Mon

The I Mon signal is a true output current monitoring signal. All internal offsets due to feedback divider currents have been compensated for.

Signature Resistor

A unique identifying signature resistor for each type of unit is connected from Pin 1A to ground. Details if desired are available upon request.

I Sense Signal

The polarity of the I Sense signal is opposite of the polarity of the output voltage of the unit that generated it. So a positive output polarity unit creates a negative polarity current monitor signal; while a negative output polarity unit creates a positive polarity current monitoring signal. This signal is clamped to ground internally via a bidirectional transient protection device and the signal is made available via a series connected 47kΩ isolation resistor. Internal HV dividers create a small, linear offset voltage on this current monitor signal that can be compensated for.

OT Output

The unit is protected by an internal thermostat that will shut the unit off if the case temperature exceeds 65°C. The OT Output signal will change states indicating an over temperature fault has occurred. In order to clear the OT signal and re-enable the unit, the temperature has to drop below 55 degrees C and input power needs to be recycled. For details on unit cooling requirements and the OT Output signal please see the operator's manual.

SHIELDING OPTIONS (CONT)

M Option

Mu Metal Shield-

UM modules can be fitted with an adhesive backed Mu Metal foil shield to help protect sensitive adjacent circuitry.



Same as standard unit.
See page 6 of 6 for dimensional drawings

CHASSIS MOUNTING OPTION

E Option

Eared Mounting Plate-

An eared mounting plate is affixed to the top surface of the UM module allowing simple chassis mounting of unit.

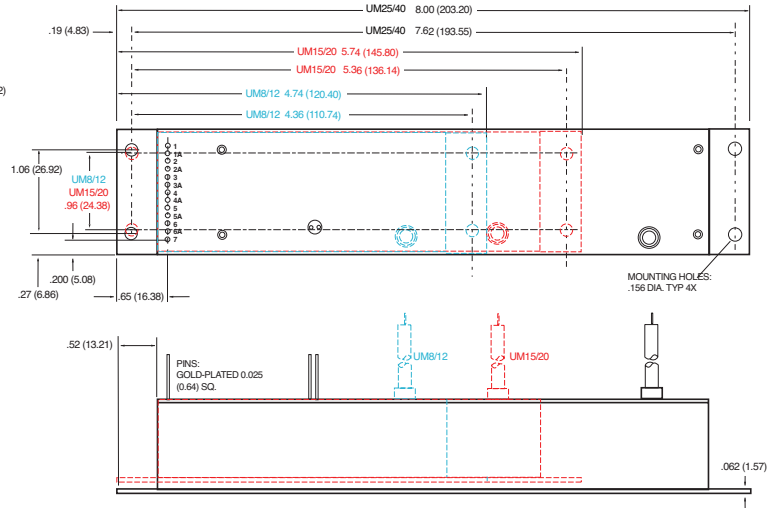
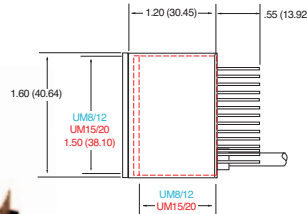
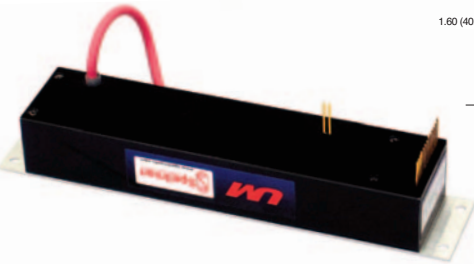

ORDERING INFORMATION

Voltage	0 to 8kV	8
	0 to 10kV	10
	0 to 12kV	12
	0 to 15kV	15
	0 to 20kV	20
	0 to 25kV	25
	0 to 30kV	30
	0 to 35kV	35
	0 to 40kV	40
Polarity	Positive	P
	Negative	N
Power	Watts Output	4
	Watts Output	15
	Watts Output	30

STANDARD UNIT ORDERING EXAMPLE

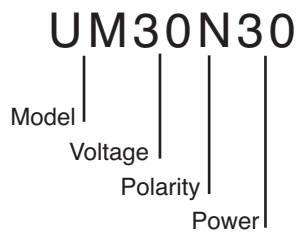

OPTION ORDERING INFORMATION

OPTION	OPTION CODE
Legacy Interface	L
Fast Rise Time	C
Low Temperature Coefficient	T
Mu Metal Shield	M
RF Tight Shielded Can	S
Eared Mounting Plate	E
Terminal Block	B

OPTION ORDERING EXAMPLE

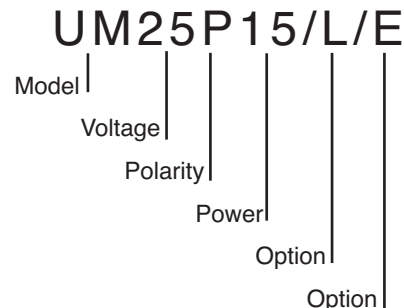

DIMENSIONS: in.[mm]

15 PIN - Standard Interface

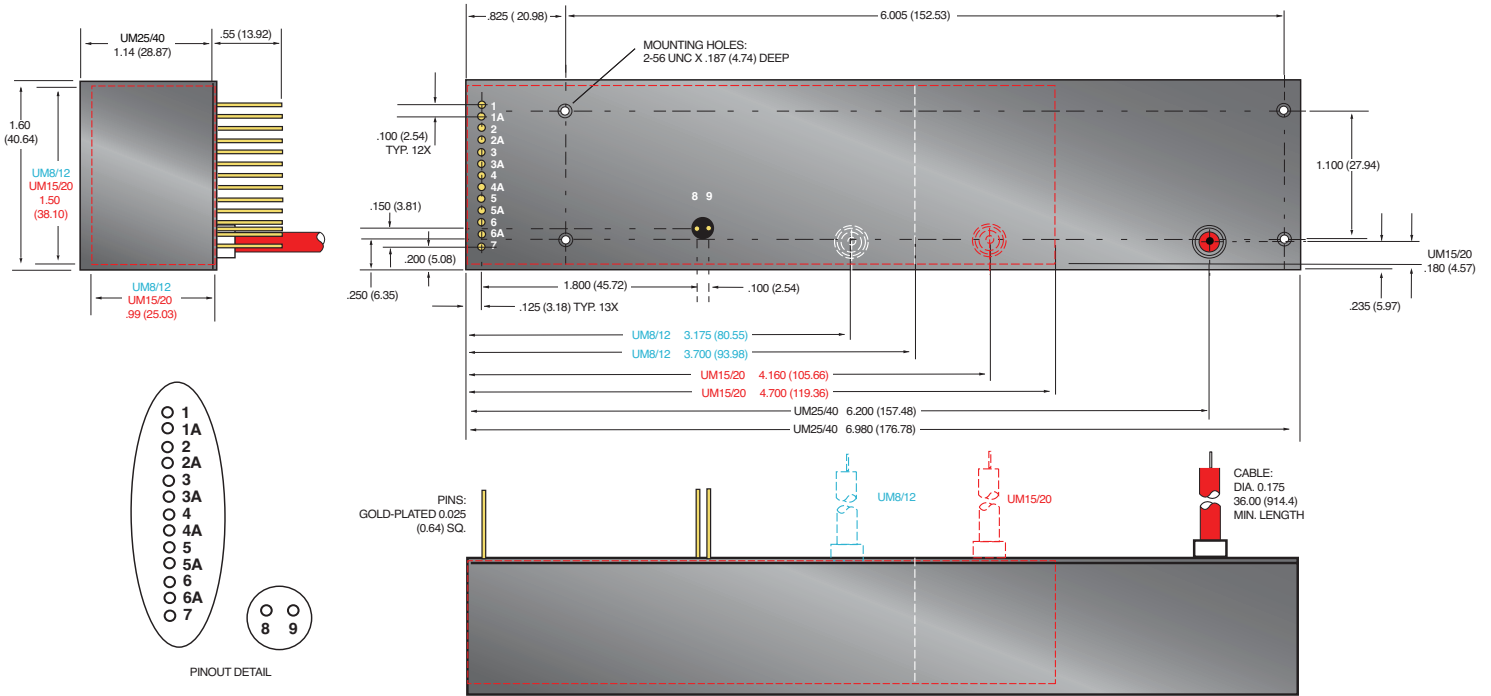

9 PIN - Legacy Interface

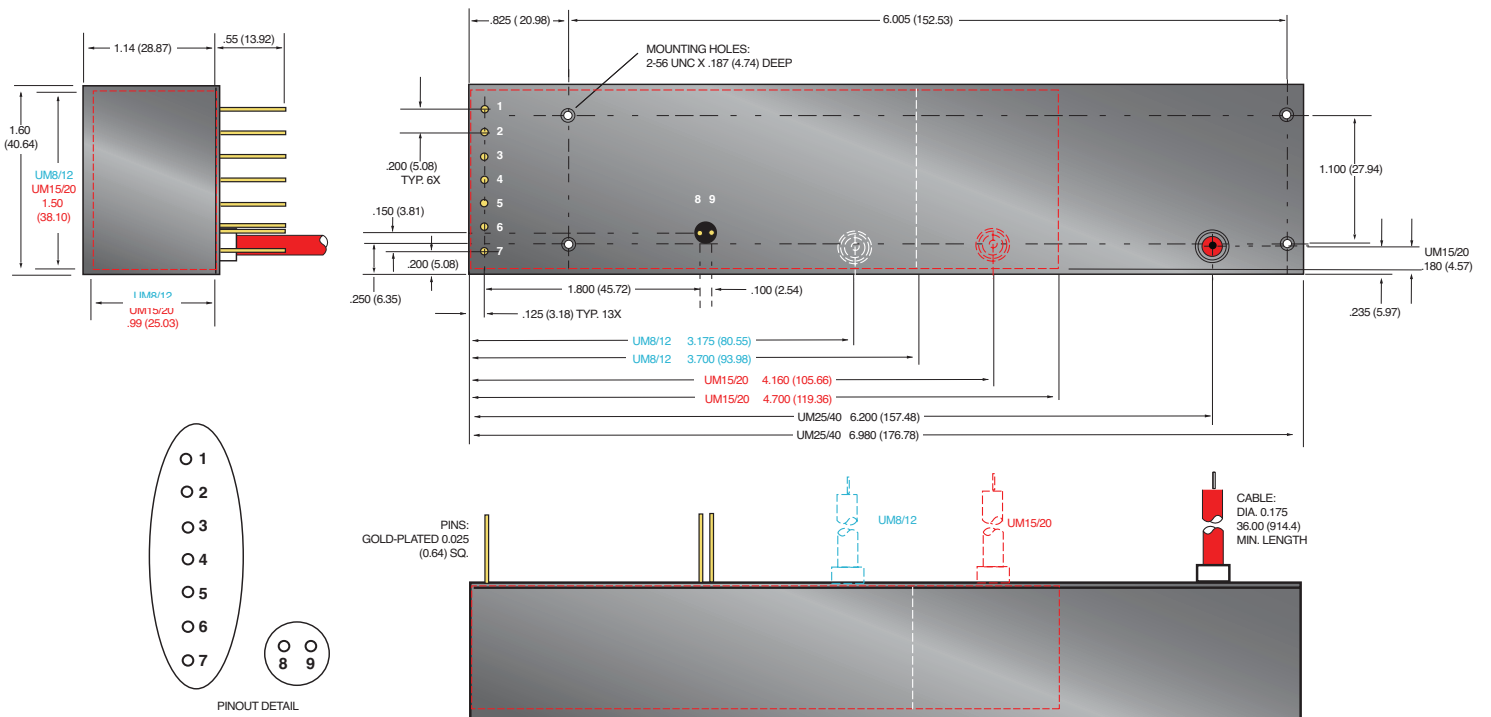



- **Differential Input for Voltage Program**
- **Optional RS-232/RS-485 Control**
- **10 Watts Output Power**
- **Voltage and Current Monitors and Controls**
- **High Stability**
- **Ultra Low Ripple and Noise**
- **CE Marked and UL61010-1 Certified**

www.spellmanhv.com/manuals/MPS

Operators Manual

www.spellmanhv.com/MPS/faq

FAQ's

www.spellmanhv.com/MPS/dcc

Digital Interface

Spellman's new MPS series are a family of high voltage 10 Watt modules that provide output voltages ranging from 1kV to 30kV.

The MPS series are high performance products designed with Spellman's hybrid topology of linear and switch mode power conversion techniques delivering lower noise with higher efficiency. The MPS series produces excellent ripple and stability performance specifications from a compact footprint. Additionally the MPS series features, as standard, a differential amplifier input for the voltage programming signal to improve immunity from external system noise and addressing any offset issues. Alternatively the output voltage may be pre-set by an internal potentiometer.

A fully featured remote user interface is provided via 15-pin D-type connector as standard and an optional RS-232 or RS-485 serial interface is also available.

Spellman's proprietary HV technology coupled with SMT circuitry results in an ultra compact and lightweight module that is available as either a positive or negative supply that is ideal for OEM applications.

TYPICAL APPLICATIONS

Photomultiplier Tubes	Electrostatic Printing
Electron and Ion Beams	Scintillators
Electronmultiplier Detectors	Mass Spectrometry
Microchannel Plate Detectors	Electrostatic Lenses
Nuclear Instruments	

OPTIONS

VCC	Variable Current Control
HS	High Stability
DCC 2	RS-232
DCC 4	RS-485

Note: It is not possible to supply the unit with both full HS and DCC options

SPECIFICATIONS

Input Voltage:

+24 Vdc, ±2Vdc

Input Current:

≤1 amp maximum

Output Voltage:

9 models available from 1kV to 30kV

Output Polarity:

Positive or negative, specify at time of order

Power:

10 watts, maximum

Voltage Regulation:

Line: ≤0.001% of rated output voltage over specified input voltage

Load: ≤0.001% of rated output voltage for full load change

Current Regulation (VCC Option):

Line: ≤0.01% for 1V input voltage change under any load conditions

Load: ≤0.01% for full load to short circuit

Ripple:

See "model selection" table

Stability:

≤0.007% per hour, 0.02% per 8 hours after 1.0 hour warm up period.
 ≤0.05% per 1000 hours after 1.0 hour warm up period (HS option)

Temperature Coefficient:

≤25ppm per degree C

≤10ppm per degree C (HS option)

Environmental:

Temperature Range:

Operating: 0°C to 50°C

Storage: -35°C to 85°C

Humidity:

20% to 85% RH, non-condensing

Cooling:

Convection cooled

Dimensions:

- 1-10kV: 1.18" H X 2.75" W X 5.12" D
(30mm x 70mm x 130mm)
- 15-20kV: 1.18" H X 2.75" W X 6.49" D
(30mm x 70mm x 165mm)
- 30kV: 1.37" H X 2.95" W X 8.47" D
(65mm x 75mm x 215mm)

Weight:

- 1-3kV: 9.88 oz. (280g)
- 5-10kV: 14.82 oz. (420g)
- 15-20kV: 22.92 oz. (650g)
- 30kV: 35.51 oz. (950g)

Interface Connector:

15 pin male D connector

Output Connector:

A captive 39.4" (1 meter) long shielded HV cable is provided

Regulatory Approvals:

Compliant to EEC EMC Directive. Compliant to EEC Low Voltage Directive. UL/CUL recognized, File E227588. RoHS compliant.

**MPS ANALOG INTERFACE—
15 PIN D CONNECTOR (DCC UNITS)**

PIN	SIGNAL	SIGNAL PARAMETERS
1	Power/Signal Ground	Ground
2	+24Vdc Input	+24Vdc @ 1 amp maximum
3	No Connection	No Connection
4	Local Programming Potentiometer Wiper Output	Potentiometer connected to +10Vdc and Ground, 0 to 10Vdc adjustable wiper output provided
5	No Connection	No Connection
6	No Connection	No Connection
7	No Connection	No Connection
8	No Connection	No Connection
9	No Connection	No Connection
10	No Connection	No Connection
11	No Connection	No Connection
12	Enable Input	Low = Enable, TTL, CMOS, open collector compliant
13	No Connection	No Connection
14	TxD	Transmit data (output) with respect to ground (pin 1)
15	RxD	Receive data (input) with respect to ground (pin 1)

Notes: 1.) The DCC option operated via a simple ASCII protocol. Contact us for more information.
2.) The HS and DCC option cannot be offered together

**MPS ANALOG INTERFACE—
15 PIN D CONNECTOR (NON-DCC UNITS)**

PIN	SIGNAL	SIGNAL PARAMETERS
1	Power/Signal Ground	Ground
2	+24Vdc Input	+24Vdc @ 1 amp maximum
3	Voltage Monitor Output	0 to 10Vdc=0 to 100% Rated Output, Zout =10kΩ
4	Local Programming Potentiometer Wiper Output	Potentiometer connected to +10Vdc and Ground, 0 to 10Vdc adjustable wiper output provided
5	Voltage Program Input	0 to 10Vdc=0 to 100% Rated Output, Zin=10MΩ
6	Voltage Program Differential Amplifier Output	0 to 10Vdc=0 to 100% Rated Output, Zout =10kΩ
7	Voltage Program Differential Amplifier Input—Positive	0 to 10Vdc differential between pin 7 and pin 9 = 0 to 100% of rated output, diode clamped to ground, Zin =38kΩ
8	Current Monitor Output	0 to 10Vdc = 0 to 100% Rated Output, Zout =10kΩ
9	Voltage Program Differential Amplifier Input—Negative	0 to 10Vdc differential between pin 7 and pin 9 = 0 to 100% of Rated Output, diode clamped to ground, Zin =38kΩ
10	No Connection	No Connection
11	Current Program Input	Standard: Internally connected to provide 110% fixed current limit VCC Option: 0 to 10Vdc=0 to 100% Rated Output, Zin=1MΩ
12	Enable Input	Low = Enable, TTL, CMOS, Open Collector Compliant
13	Internal Connection	No Connection
14	Vref (/HS unit only)	+10V ultra high stability reference output. On standard units the reference voltage is available on pin 4
15	Analog Signal Ground (15kV to 20kV units)	Analog Signal Ground (No connection for (1kV to 10kV units)

MPS SELECTION TABLE

Model	Output Voltage	Output Current	Ripple (Vpp)
MPS1*10/24	1kV	10mA	<10mV
MPS2*10/24	2kV	5.00 mA	<20mV
MPS2.5*10/24	2.5kV	4.00 mA	<25mV
MPS3*10/24	3kV	3.3mA	<25mV
MPS5*10/24	5kV	2mA	<30mV
MPS10*10/24	10kV	1mA	<50mV
MPS15*10/24	15kV	0.66mA	<100mV
MPS20*10/24	20kV	0.5mA	<150mV
MPS30*10/24	30kV	0.33mA	<250mV

*Specify "P" for positive polarity or "N" for negative polarity. Custom units available.

DIMENSIONS: in.[mm]

**1-20kV
FRONT VIEW**

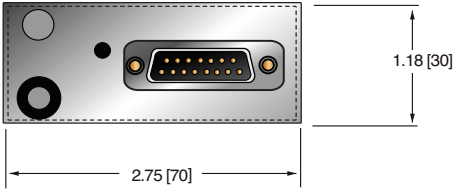

**30kV
FRONT VIEW**

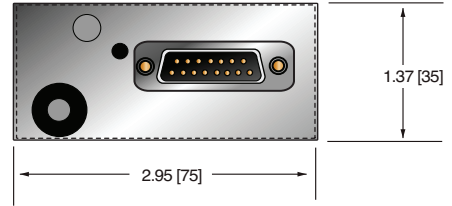

BOTTOM VIEW

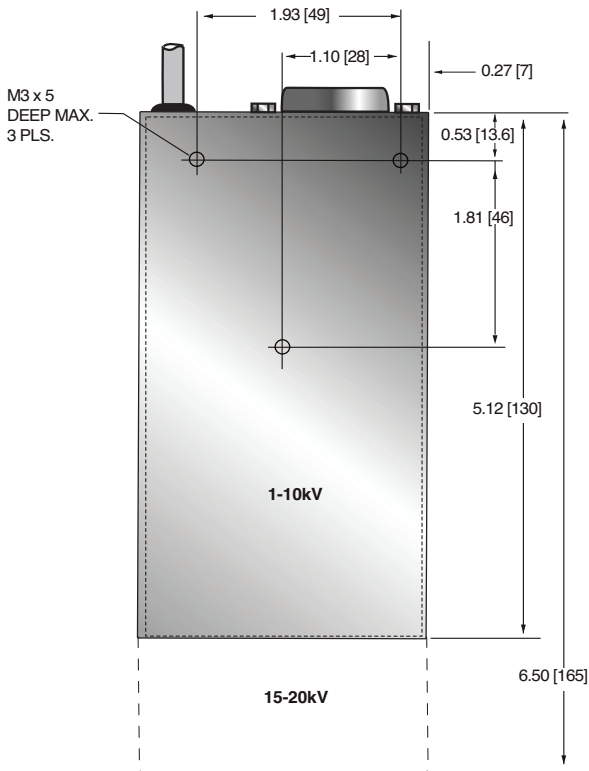

BOTTOM VIEW

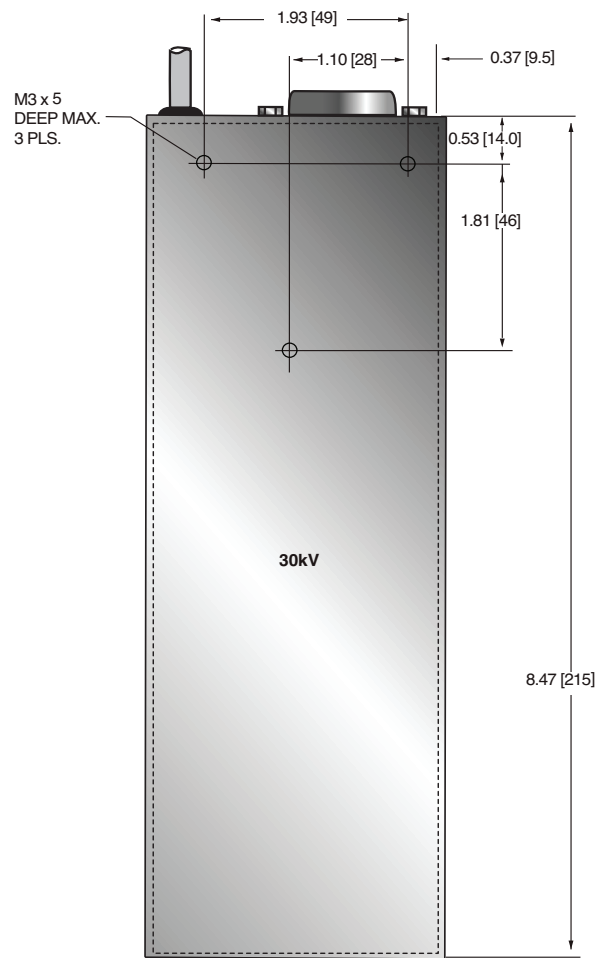

SIDE VIEW



SIDE VIEW





- **Extremely Compact High Performance Module**
- **Digital or Differential Analog Voltage Program**
- **Standard RS-232/RS-485 Control**
- **10 Watts Output Power**
- **Voltage and Current Monitors**
- **High Stability, Low TC**
- **Digital Oscillator Provides Ultra Low Ripple and Noise, Down to 1/f Band**

Spellman's new MPD series are a family of high voltage 10 Watt modules that provide output voltages ranging from 2.5kV to 20kV.

The MPD series are high performance products designed with Spellman's hybrid topology of linear and switch mode power conversion techniques delivering lower noise with higher efficiency. The MPD series produces excellent ripple and stability performance specifications from a compact footprint. The MPD series features a differential amplifier input for the voltage programming signal to improve immunity from external system noise and addressing any offset issues.

A fully featured remote user interface is provided via 15-pin D-type connector as well as RS-232/RS-485 serial interface. The unit can be full analog or full digital control defined by interface connector links.

Spellman's proprietary HV technology coupled with SMT circuitry results in an ultra compact and lightweight module that is available as either a positive or negative supply that is ideal for OEM applications.

TYPICAL APPLICATIONS

Photomultiplier Tubes	Electrostatic Printing
Electron and Ion Beams	Scintillators
Electronmultiplier Detectors	Mass Spectrometry
Microchannel Plate Detectors	Electrostatic Lenses
Nuclear Instruments	

SPECIFICATIONS

Input Voltage:

+24 Vdc, ±2Vdc

Input Current:

≤1 amp maximum

Output Voltage:

5 models available from 2.5kV to 20kV

Output Polarity:

Positive or negative, specify at time of order

Power:

10 watts, maximum

Voltage Regulation:

Line: For a 1V line change 10ppm
Load: 0-100% load 10ppm

Current Limit:

110% of rated output current

Ripple:

See "drift, ripple and noise" table

Stability:

70ppm per hour after one hour warm up period.
500ppm per 1000 hours after one hour warm up period.

Temperature Coefficient:

10ppm per degree C

Protection:

Arc and short circuit protected. Not designed to withstand continuous arcing

Environmental:

Temperature Range:
Operating: 0°C to 50°C
Storage: -35°C to 85°C
Humidity:
20% to 85% RH, non-condensing

Cooling:

Convection cooled

Dimensions:

2.5-10kV:
1.18" H X 2.75" W X 5.12" D (30mm x 70mm x 130mm)
15-20kV:
1.18" H X 2.75" W X 6.50" D (30mm x 70mm x 165mm)

Weight:

2.5/5/10kV:
14.82 oz. (420g)
15/20kV:
22.09 oz. (650g)

Interface Connector:

15 pin male D connector

Output Connector:

A captive 39.4" (1 meter) long HR658 shielded HV cable is provided

Regulatory Approvals:

Safety: The unit is designed to meet the requirements of EN61010-1, UL61010A-1 and CAN/CSA 22.2 No 1010.1.
EMC: As the unit is intended for incorporation into the users equipment, it is not tested as a standalone unit to meet the EMC directive. The user will need to follow sensible EMC precautions in using the unit.

MPD SELECTION TABLE

Model	Output Voltage	Output Current	Ripple (Vpp)
MPD2.5*10/24	2.5kV	4.00 mA	See table below
MPD5*10/24	5kV	2mA	See table below
MPD10*10/24	10kV	1mA	See table below
MPD15*10/24	15kV	0.66mA	See table below
MPD20*10/24	20kV	0.5mA	See table below

*Specify "P" for positive polarity or "N" for negative polarity.
Custom units available.

MPD DRIFT, RIPPLE and NOISE

Model	3mHz-30mHz	30mHz-3Hz	3Hz-30Hz	30Hz-300Hz	300Hz-30kHz	30kHz-3MHz
MPD2.5	10mV	10mV	10mV	5mV	5mV	5mV
MPD5	10mV	10mV	10mV	10mV	10mV	10mV
MPD10	20mV	20mV	20mV	20mV	20mV	20mV
MPD15	30mV	30mV	30mV	30mV	30mV	30mV
MPD20	40mV	40mV	40mV	40mV	40mV	40mV

MPD EXTERNAL INTERFACE— 15 PIN MALE D CONNECTOR

PIN	SIGNAL	SIGNAL PARAMETERS
1	Power Ground	Ground
2	+24Vdc Input	+24Vdc @ 1 amp maximum
3	Voltage Monitor Output	Voltage monitor 0-10Vdc for 0 to full scale output ±1% (wrt signal ground)
4	Voltage Reference Output	10Vdc @ 1mA maximum
5	Voltage Program Input	0 to 10Vdc=0 to 100% rated output, Z _{in} =10MΩ
6	Voltage Program Differential Amplifier Output	0 to 10Vdc=0 to 100% rated output, Z _{out} =10kΩ
7	Voltage Program Differential Amplifier Input—Positive	0 to 10Vdc differential between pin 7 and pin 9 = 0 to 100% of rated output, diode clamped to ground, Z _{in} =38kΩ
8	Current Monitor Output	Voltage monitor 0-10Vdc for 0 to full scale output ±1% (wrt signal ground)
9	Voltage Program Differential Amplifier Input—Negative	0 to 10Vdc differential between pin 7 and pin 9 = 0 to 100% of rated output, diode clamped to ground, Z _{in} =38kΩ
10	Voltage Program Digital Output	0 to 10Vdc = 0 to 100% rated output, Z _{out} =10kΩ
11	Analog Signal Ground	Analog signal ground for control and monitoring
12	Enable Input	Low = Enable, TTL, CMOS, open collector compliant
13	Digital Mode	RS-232 or RS-485 configuration Low = RS-485, Open circuit = RS-232
14	RS-232 TxD/RS-485 (-)	Transmit data (output) wrt pin 1 or RS-485 inverting
15	RS-232 RxD/RS-485 (+)	Receive data (input) wrt pin 1 or RS-485 non inverting

Digital Control – Connect pin 5 to pin 10
Analog Control – Connect pin 5 to pin 6

DIMENSIONS: in.[mm]

FRONT VIEW

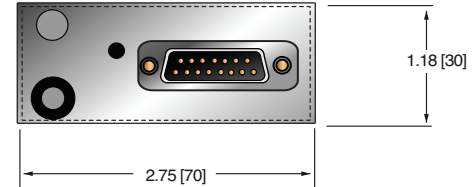

BOTTOM VIEW

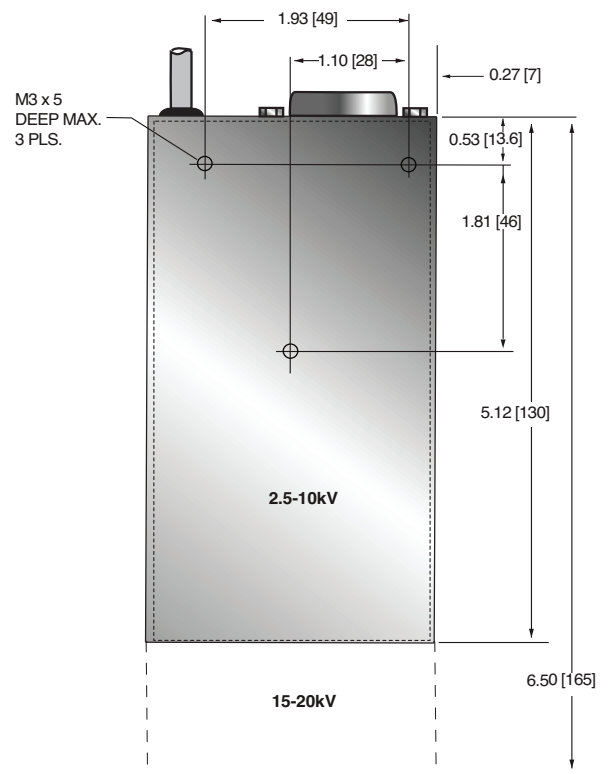

SIDE VIEW





Spellman's Bertan brand of 230 Series high voltage power supplies provide regulated high voltage outputs from 1 to 30kV. The low noise, linear topology employed results in extremely low output ripple specifications. These 12 to 15W units are inherently reversible by design, providing either positive or negative output polarity. The 230 Series is fully arc and short circuit protected. Excellent regulation specifications are featured along with outstanding stability performance.

TYPICAL APPLICATIONS

HiPot Testing
Electrostatics
General Laboratory Usage

OPTIONS

F Isolated (Floating) Output

SPECIFICATIONS

Input Voltage:

115Vac, $\pm 10\%$, 50/60Hz @ 0.5A
230Vac, $\pm 10\%$, 50/60Hz @ 0.25A
Input voltage is switch selectable

Output Voltage:

See "model selection" table

Output Polarity:

All units are reversible polarity by design

Output Current:

See "model selection" table

Voltage Regulation:

Line: $\pm 0.002\%$ of rated output voltage over specified input voltage range
Load: $\pm 0.005\%$ of rated output voltage for a full load change

Current Regulation:

Internally set to limit at less than 125% of rated current.
A rear panel switch allows limiting at 25% of rated full current.

Ripple:

See "model selection" table

Temperature Coefficient:

$\leq 100\text{ppm}/^\circ\text{C}$

 Not Intended For New Designs

- **Modular Bench Top Design Design**
- **Low Ripple and Noise**
- **3.5 Digit Front Panel Digital Metering**
- **Reversible Output Polarity**

www.spellmanhv.com/manuals/230

Stability:

$\leq 0.01\%$ /hour, 0.02% per 8 hours after a 1/2 hour warm up

Accuracy:

Front panel control: $\pm(0.2\%$ of setting + 0.2% of maximum)
Front panel Meter: Voltage $\pm(0.5\%$ of setting + 0.5% of maximum), Current $\pm(2\%$ of setting + 0.5% of maximum)
Remote Programming: $\pm(0.1\%$ of setting + 0.1% of maximum)
Voltage Monitor: $\pm(0.1\%$ of reading + 0.1% of maximum)
Current Monitor: $\pm(2\%$ of reading + 1% of maximum)

Front Panel Metering and Controls:

Power ON/OFF switch
3.5 digit metering for voltage and current, switch selectable
Polarity indicator
10 turn locking potentiometer to set output voltage
HV output connector
Ground stud

Operating Temperature

0°C to +50°C

Storage Temperature:

-40°C to +85°C

Humidity:

20% to 85% RH, non-condensing

Input Line Connector:

IEC320 EMI filter/input connector, a detachable line cord is provided

Interface Connector:

9 pin "D" connector, a mating connector is provided

Output Connector:

A detachable 10 foot (3 meter) HV cable is provided for units up to 5kV; 10kV through 20kV: 59" (1.5 meter); 30kV: 10 foot (3 meter)

Cooling:

Convection cooled

Dimensions

7.63" W X 5.03" H X 8.91" D
(194mm X 128mm X 226mm)

Weight:

$\leq 10\text{lbs}$ (4.5kg)

MODEL SELECTION TABLE

230 Series	Voltage	Current	Ripple
230-01R	0 to 1kV	0 to 15mA	10mV
230-03R	0 to 3kV	0 to 5mA	30mV
230-05R	0 to 5kV	0 to 3mA	50mV
230-10R	0 to 10kV	0 to 1.5mA	500mV
230-20R	0 to 20kV	0 to 0.5mA	2V
230-30R	0 to 30kV	0 to 0.4mA	5V

INTERFACE CONNECTOR

PIN	SIGNAL	PARAMETERS
1	Voltage Monitor	0 to 5Vdc = 0 to 100% rated voltage, Zout = 10KΩ
2	N/C	No Connection
3	Enable	TTL "0" disables HV, TTL "1" or open enables HV
4	+5Vdc Reference	+5.0Vdc @ 10mA, maximum
5	Current Monitor	0 to 5Vdc = 0 to 100% rated current, Zout = 10KΩ
6	Voltage Program Input	0 to 5Vdc = 0 to 100% rated voltage, Zin = 1MΩ
7	Analog Ground	Ground
8	Digital Ground	Ground
9	Polarity Indicator	Open collector, 30V @ 25mA, positive = ON

OPTIONS:

Isolated (Floating) Output-Option F

Units up to and including 5kV can be provided with differential outputs capable of floating up to ±2kV from ground. Voltage programming and monitoring functions are normally referenced to ground. Current monitoring and metering is eliminated. Replace "R" suffix with "F" for this option. Output connectors (positive, negative and ground) for 1kV and 3kV models are 3-way binding posts; 5kV model uses Spellman P/N JAC for positive and negative outputs with 3-way binding post for ground. Mating connectors are Spellman P/N PA (MHV type 1705-14)

DIMENSIONS: in.[mm]

FRONT VIEW

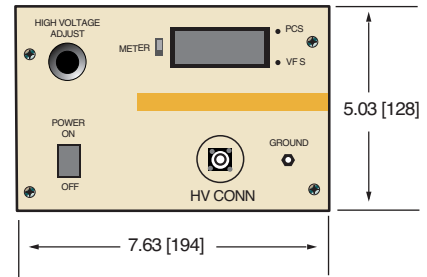

SIDE VIEW

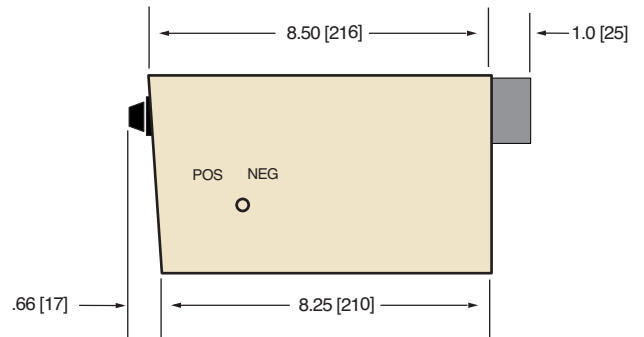

BACK VIEW

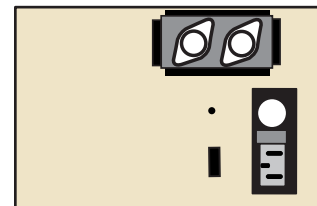



- **Differential Input for Voltage Program**
- **20 Watts Output Power**
- **Voltage and Current Controls**
- **Voltage and Current Monitors**
- **High Stability**
- **Ultra Low Ripple and Noise**
- **High Voltage Enable Control**

www.spellmanhv.com/manuals/MPS20W

Spellman's new MPS20W series are a family of high voltage 20 Watt modules that provide output voltages ranging from 1kV to 20kV.

The MPS20W series are high performance products designed with Spellman's hybrid topology of linear and switch mode power conversion techniques delivering lower noise with higher efficiency. The MPS20W series produces excellent ripple and stability performance specifications from a compact footprint. Additionally the MPS20W series features, as standard, a differential amplifier input for the voltage programming signal to improve immunity from external system noise and addressing any offset issues. Alternatively the output voltage may be pre-set by an internal potentiometer. A fully featured remote user interface is provided via 15-pin D-type connector as standard. The output voltage is arc and short circuit protected and the power input has a current limiter fitted.

Spellman's proprietary HV technology coupled with SMT circuitry results in an ultra compact and lightweight module that is available as either a positive or negative supply that is ideal for OEM applications.

TYPICAL APPLICATIONS

Photomultiplier Tubes
Microchannel Plate Detectors
Scintillators
Mass Spectrometry
Electron and Ion Beams
Electrostatic Lenses
Nuclear Instruments
Electrostatic Printing

OPTIONS

VCC Variable Current Control

SPECIFICATIONS

Input Voltage:

+24 Vdc, ± 2 Vdc

Input Current:

≤ 1.5 amps

Output Voltage:

7 models available from 1kV to 20kV

Output Polarity:

Positive or negative, specify at time of order

Power:

≤ 20 watts

Voltage Regulation:

Line: $\leq 0.001\%$ of rated output voltage over specified input voltage

Load: $\leq 0.001\%$ of rated output voltage for full load change

Current Regulation (Vcc Option):

Line: $\leq 0.01\%$ for 1V input voltage change under any load conditions

Load: $\leq 0.001\%$ for 0 to full load

Ripple:

See "model selection" table

Stability:

$\leq 0.01\%$ per hour, 0.02% per 8 hours after 1.0 hour warm up period.

Temperature Coefficient:

≤ 25 ppm per degree C

Environmental:

Temperature Range:

Operating: 0°C to 50°C

Storage: -35°C to 85°C

Humidity:

20% to 85% RH, non-condensing

Cooling:

Convection cooled

Dimensions:

1-10kV 1.31" H x 3.74" W x 5.91" D (33.5mm x 95mm x 150mm)

15-20kV 1.31" H x 3.74" W x 7.28" D (33.5mm x 95mm x 185mm)

Weight:

1-2kV: 15.17 oz. (430g)

3-10kV: 25.76 oz. (730g)

15-20kV: 35.30 oz. (1000g)

Interface Connector:

15 pin male D connector

Output Connector:

A captive 39.4" (1 meter) long shielded HV cable is provided

Regulatory Approvals:

Compliant to EEC EMC Directive. Compliant to EEC Low Voltage Directive. UL/CUL recognized, File E227588. RoHS compliant.

MPS20W SELECTION TABLE

Model	Output Voltage	Output Current	Ripple (Vpp)
MPS1*20/24	0-1kV	20mA	<25mV
MPS2*20/24	0-2kV	10 mA	<50mV
MPS3*20/24	0-3kV	6.67mA	<75mV
MPS5*20/24	0-5kV	4mA	<125mV
MPS10*20/24	0-10kV	2mA	<250mV
MPS15*20/24	0-15kV	1.33mA	<375mV
MPS20*20/24	0-20kV	1mA	<500mV

*Specify "P" for positive polarity or "N" for negative polarity.
Custom units available.

MPS20W ANALOG INTERFACE — 15 PIN D CONNECTOR

PIN	SIGNAL	SIGNAL PARAMETERS
1	Power/Signal Ground	Ground
2	+24Vdc Input	+24Vdc @ 1.5 amp maximum
3	Voltage Monitor Output	0 to 10Vdc=0 to 100% Rated Output, Zout =2.2kΩ
4	Local Programming Potentiometer Wiper Output	Potentiometer connected to +10Vdc and Ground, 0 to 10Vdc adjustable wiper output provided
5	Voltage Program Input	0 to 10Vdc=0 to 100% Rated Output, Zin=10MΩ
6	Voltage Program Differential Amplifier Output	0 to 10Vdc=0 to 100% Rated Output, Zout =2.2kΩ
7	Voltage Program Differential Amplifier Input—Positive	0 to 10Vdc differential between pin 7 and pin 9 = 0 to 100% of rated output, diode clamped to ground, Zin =38kΩ
8	Current Monitor Output	0 to 10Vdc = 0 to 100% Rated Output, Zout =2.2kΩ
9	Voltage Program Differential Amplifier Input—Negative	0 to 10Vdc differential between pin 7 and pin 9 = 0 to 100% of Rated Output, diode clamped to ground, Zin =38kΩ
10	No Connection	No Connection
11	Current Program Input	Standard: Internally connected to provide 110% fixed current limit VCC Option: 0 to 10Vdc=0 to 100% Rated Output, Zin=1MΩ
12	Enable Input	Low = Enable, TTL, CMOS, Open Collector Compliant
13	Internal Connection	No Connection
14	No Connection	No Connection
15	Analog Signal Ground	Analog Signal Ground

DIMENSIONS: in.[mm]

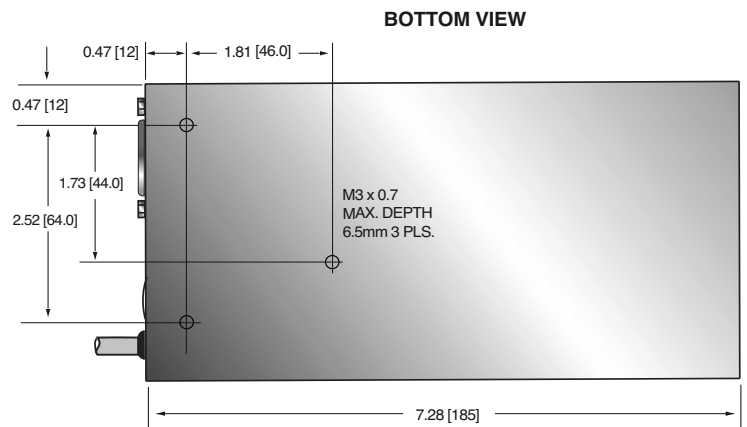
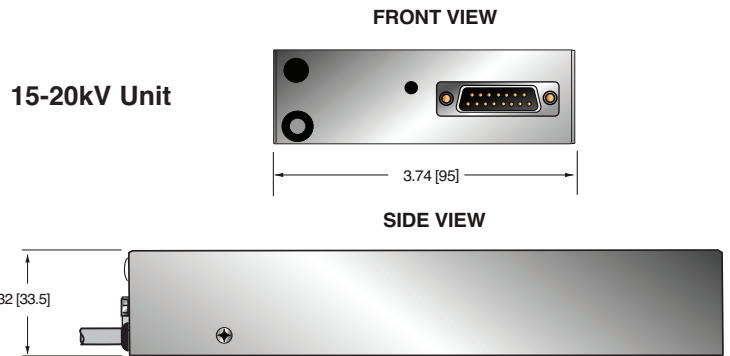
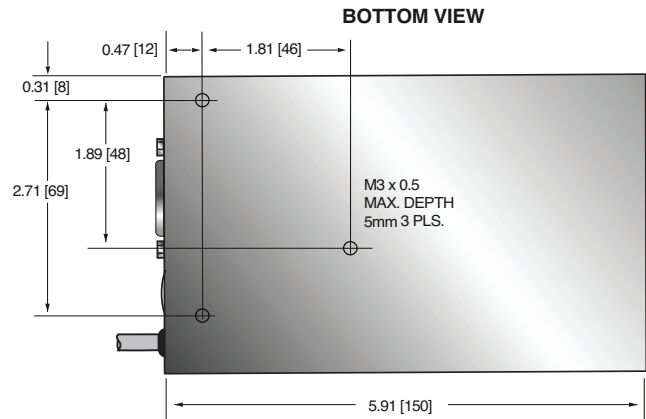
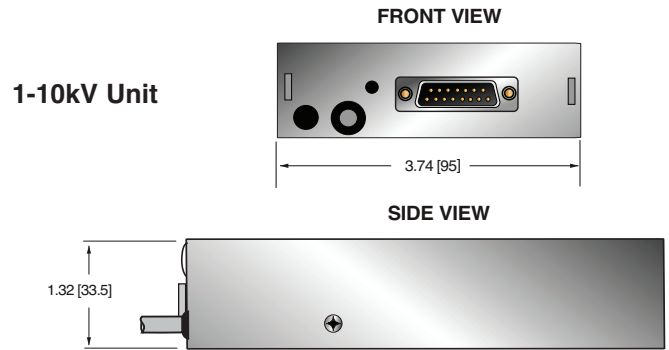



- **Compact Package**
- **Voltage and Current Programming from Zero to Rated Output**
- **Test Points for Output Current and Voltage**
- **Control of Output Via Enable/Inhibit Signal**
- **OEM Customization Available**

www.spellmanhv.com/manuals/EPM

The EPM series of high voltage power supplies provides very well regulated, low ripple high voltage in a highly efficient, compact design.

The output voltage and current are controllable over the full range of operation. Voltage and current programming and monitoring signals are all 0-10Vdc where corresponds to 0 to 100% rated output. A High Voltage Inhibit/Enable signal allows for simple on/off control of the power supply.

TYPICAL APPLICATIONS

Electrophoresis	Photomultipliers
Electron Beam	Laboratory Applications
Ion Source	Electrospinning

SPECIFICATIONS

Input:

+24Vdc \pm 10% @ 2A

Output:

8 models from 1kV to 30kV. Each model is available in positive or negative polarity output.

Voltage Regulation:

Load: 0.02% of output voltage for a full load change.
Line: 0.01% for \pm 10% change in input voltage.

Current Regulation:

Load: 0.01% of output current from 0 to rated voltage.
Line: 0.01% of rated current over specified input range.

Ripple:

0.1% p-p of maximum rated output voltage.

Dimensions:

2.06"H x 5.63"W x 5.69"D
(52.32mm x 143mm x 144.53mm)

Weight:

2.2 pounds (1kg)

Input Connector:

9 pin AMP Metri-Mate. Mating connector and pins supplied.

Output Cable:

18" \pm 1" (457mm) of UL[®] listed high voltage wire.

Voltage Stability:

0.02% per 8 hours (after 1/2 hour warm-up).

Voltage Temperature Coefficient:

0.01% per $^{\circ}$ C.

Voltage Test Point:

10Vdc \pm 2% = maximum rated output.

Current Test Point:

10Vdc \pm 2% = maximum rated output.

Remote Enable:

3.4Vdc = HV ON.
1.0Vdc or open = HV OFF.

Regulatory Approvals:

Compliant to EEC EMC Directive. Compliant to EEC Low Voltage Directive. UL/CUL recognized, File E148969

EPM SELECTION TABLE

Maximum Rating kV	Rating mA	Model Number
1	30	EPM 1*30
3	10	EPM 3*30
5	6	EPM 5*30
10	3	EPM 10*30
15	2	EPM 15*30
20	1.5	EPM 20*30
25	1.2	EPM 25*30
30	1	EPM 30*30

*Specify "P" for positive polarity or "N" for negative polarity.

INPUT – 9 PIN AMP CONNECTOR

PIN	SIGNAL	PARAMETERS
1	Power Ground	Power Ground
2	+24Vdc	+24Vdc @ 1.85 amps, maximum
3	High Voltage Enable/Inhibit	0Vdc = HV OFF, +5Vdc = HV ON (see manual for details)
4	Voltage Test Point	0 to 10Vdc = 0 to 100% rated output, Zout = 10kΩ
5	Current Test Point	0 to 10Vdc = 0 to 100% rated output, Zout = 10kΩ
6	Voltage Programming	0 to 10Vdc = 0 to 100% rated output, Zin = 10MΩ
7	Current Programming	0 to 10Vdc = 0 to 100% rated output, Zin = 10MΩ
8	+10Vdc Reference	+10Vdc @ 1mA maximum
9	Signal Ground	Signal Ground

DIMENSIONS: in.[mm]

SIDE VIEW

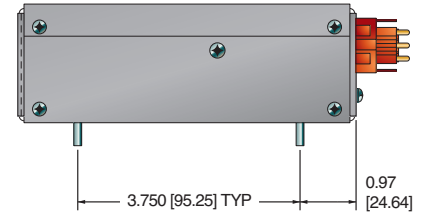

TOP VIEW

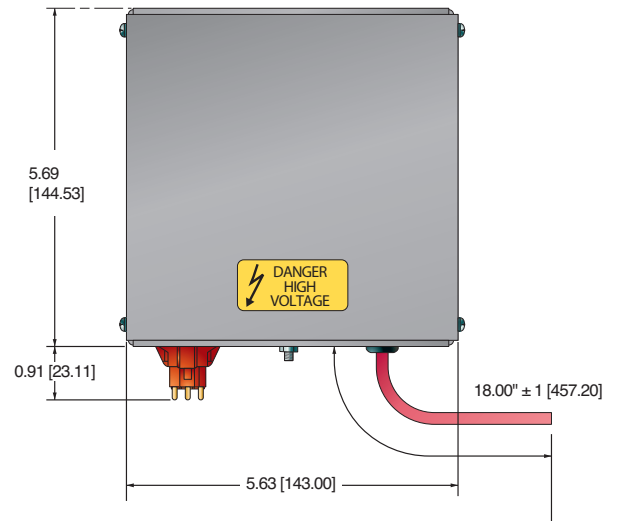

FRONT VIEW

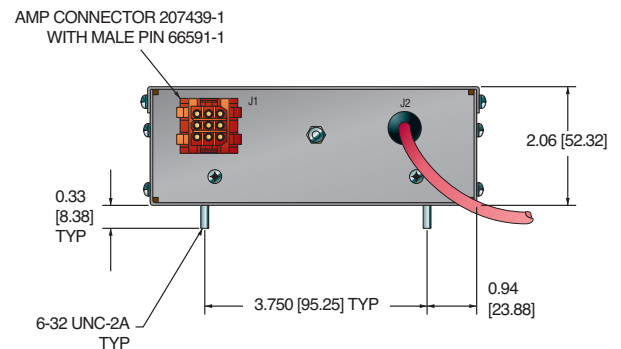



- **Compact Models up to 30kV**
- **High Stability**
- **Low Ripple and Noise**
- **Analog Control (Remote/Local)**
- **RS-232 Control (Digital Only)**
- **Voltage and Current Monitoring**
- **Arc and Short Circuit Protected**
- **OEM Customization Available**

www.spellmanhv.com/manuals/V6

The V6 Series is a family of regulated, fixed output polarity modular high voltage power supplies which provide exceptional performance and value in many applications.

The V6 Series units are fully enclosed and designed for system or bench top operation. A wide range of output voltages, up to 30kV is available.

The output voltage is controlled locally by an internal multi-turn potentiometer. Remote analog voltage or resistance programming capability is included in all models. Analog monitor outputs are also included for remote monitoring of both the high voltage and current outputs.

TYPICAL APPLICATIONS

Spectrometers
CRT Testing
Detectors
E Beam Systems
General Laboratory Usage

OPTIONS

RS RS-232 Interface (analog control not included)

SPECIFICATIONS

Input Voltage:

AC Model: 100-240Vac, $\pm 10\%$; 50/60 Hertz; 1 amp
DC Model: 24Vdc $\pm 10\%$, 2 amps

Voltage Regulation:

Line: $\pm 0.005\%$ of maximum 90-240Vac input line change
 $\pm 0.005\%$ of maximum $\pm 10\%$ Vdc input line change

Load: $\pm 0.01\%$ of maximum for 0 to maximum rated output current change

Current Regulation:

Line: $\pm 0.05\%$ of maximum current for 90-240Vac input line change
0.05% of maximum current for $\pm 10\%$ Vdc input change

Load: 0.2% of maximum current for 0 to maximum rated output voltage change

Ripple:

See "model selection" table

Temperature Coefficient:

$\leq 50\text{ppm}/^\circ\text{C}$

Stability:

$\leq 0.01\%$ /hour, 0.02% per 8 hours after a 1/2 hour warm up

Operating Temperature:

0°C to +50°C

Storage Temperature:

-40°C to +85°C

Humidity:

20% to 85%RH, non-condensing

Local Control:

Internal multi-turn potentiometer for 0 to maximum output voltage ($\pm 0.2\%$)

Remote Programming:

0 to +5Vdc analog input signal proportional to 0 to maximum rated output. Accuracy is $\pm(0.1\%$ of setting +0.1% of maximum). The programming input impedance is 20 megohms.

Voltage Monitor:

0 to +5V proportional to 0 to maximum output voltage. Accuracy is $\pm(0.1\%$ of reading +0.1% of maximum). The monitor impedance is 10 kilohms.

Current Monitor:

0 to +5V proportional to 0 to maximum output current. Accuracy is $\pm(2.0\%$ of reading +1.0% of maximum). The monitor impedance is 10 kilohms.

Enable:

Remote interlock enables (low) disables internally (high) the high voltage output. Signal is normally high and supply will default to a disabled condition.

Current Limit:

All units provide short circuit current limiting to less than 110% of the maximum rated output current. Supply is self restoring upon removal of cause limit condition.

Arc/Short Circuit:

Short circuit and arc protected; self restoring.

Cooling:

Convection cooled

Output Connector:

Models up to and including 5kV use a Spellman P/N JAC high voltage connector. The required mating connector is a Spellman P/N 105808-384, which is provided. The 10kV through 30kV units use a Spellman P/N JGP high voltage connector (Alden 8101). All 10 through 30kV units are provided with mating connectors assembled to 2.0 meters of high voltage cable.

Dimensions:

AC Model: 3.05" W X 5.1" H X 7.06" D
(77mm X 132mm X 179mm)

DC Model: 2.32" W X 5.1" H X 7.06" D
(59mm X 132mm X 179mm)

Weight:

AC Model: 4.5 pounds (2.0kg)

DC Model: 3.75 pounds (1.7kg)

Regulatory Approvals:

Compliant to EEC EMC Directive. Compliant to EEC Low Voltage Directive. UL/CUL recognized, File E227588. RoHS Compliant.

V6A MODEL SELECTION TABLE

V6 AC Series	Voltage	Current	Ripple
V6A1*30	0 to 1kV	0 to 30mA	75mV
V6A1.5*30	0 to 1.5kV	0 to 20mA	75mV
V6A3*30	0 to 3kV	0 to 10mA	120mV
V6A5*30	0 to 5kV	0 to 6mA	150mV
V6A10*30	0 to 10kV	0 to 3mA	400mV
V6A15*30	0 to 15kV	0 to 2mA	900mV
V6A20*30	0 to 20kV	0 to 1.5mA	1.0V
V6A30*30	0 to 30kV	0 to 1mA	1.8V

*Specify "P" for positive polarity or "N" for negative polarity

V6D MODEL SELECTION TABLE

V6 DC Series	Voltage	Current	Ripple
V6D1*30	0 to 1kV	0 to 30mA	75mV
V6D1.5*30	0 to 1.5kV	0 to 20mA	75mV
V6D3*30	0 to 3kV	0 to 10mA	120mV
V6D5*30	0 to 5kV	0 to 6mA	150mV
V6D10*30	0 to 10kV	0 to 3mA	400mV
V6D15*30	0 to 15kV	0 to 2mA	900mV
V6D20*30	0 to 20kV	0 to 1.5mA	1.0V
V6D30*30	0 to 30kV	0 to 1mA	1.8V

*Specify "P" for positive polarity or "N" for negative polarity

V6A ANALOG/DIGITAL INTERFACE – J1 15 PIN FEMALE D CONNECTOR

PIN	SIGNAL	SIGNAL PARAMETERS
1	Local Voltage Program	Multi-turn front panel potentiometer
2	TX Out (optional)	RS232 Receive Data
3	RX In (optional)	RS232 Transmit Data
4	Voltage Program Input	0 to 5V=0 to 100% Rated Output, Zin=20MΩ
5	Signal Ground	RS232 Ground (optional)
6	Signal Ground	Ground
7	+5V Reference Out	+5V @ 1mA Max.
8	HV Enable Input	Active Low to Enable the HV
9	Current Program Input	0 to 5V=0 to 100% Rated Output, Zin=20MΩ
10	Current Monitor	0 to 5V=0 to 100% Rated Output, Zout=10kΩ
11	Voltage Monitor	0 to 5V=0 to 100% Rated Output, Zout=10kΩ
12	HV Enable Output	Active Low HV is Enabled
13	Signal Ground	Ground
14	N/C	No Connection
15	N/C	No Connection

V6D ANALOG/DIGITAL INTERFACE – J1 15 PIN FEMALE D CONNECTOR

PIN	SIGNAL	SIGNAL PARAMETERS
1	Local Voltage Program	Multi-turn front panel potentiometer
2	TX Out (optional)	RS232 Receive Data
3	RX In (optional)	RS232 Transmit Data
4	Voltage Program Input	0 to 5V=0 to 100% Rated Output, Zin=20MΩ
5	Signal Ground	RS232 Ground (optional)
6	Signal Ground	Ground
7	+5V Reference Out	+5V @ 1mA Max.
8	HV Enable Input	Active Low to Enable the HV
9	Current Program Input	0 to 5V=0 to 100% Rated Output, Zin=20MΩ
10	Current Monitor	0 to 5V=0 to 100% Rated Output, Zout=10kΩ
11	Voltage Monitor	0 to 5V=0 to 100% Rated Output, Zout=10kΩ
12	HV Enable Output	Active Low HV is Enabled
13	+24V Return	Input Voltage Return
14	+24Vdc Input	Input Voltage 24V±10%, 2A
15	+24Vdc Input	Input Voltage 24V±10%, 2A

ORDERING EXAMPLE

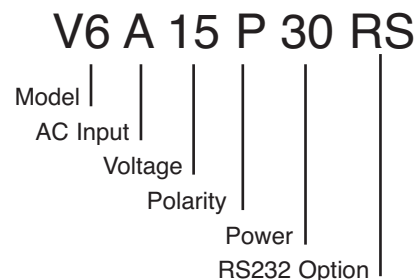

DIMENSIONS: in.[mm]

V6-AC

TOP VIEW

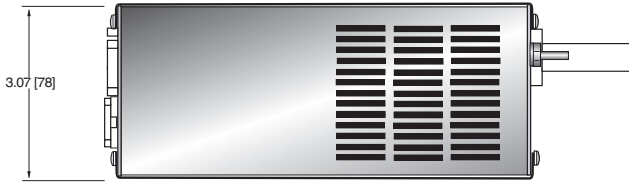

SIDE VIEW



BOTTOM VIEW

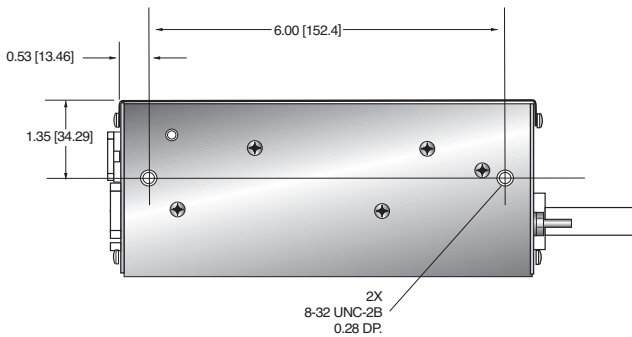

FRONT VIEW



BACK VIEW



V6-DC

TOP VIEW



SIDE VIEW

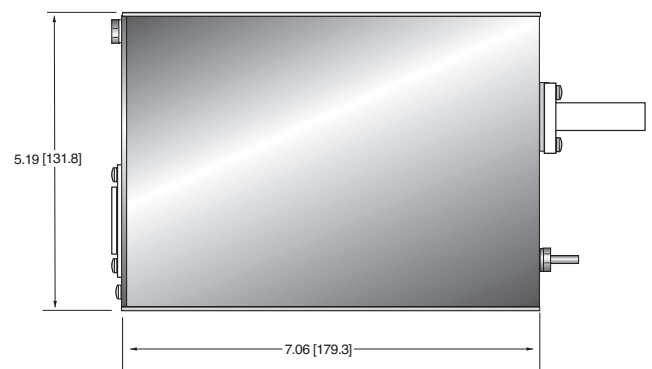

BOTTOM VIEW

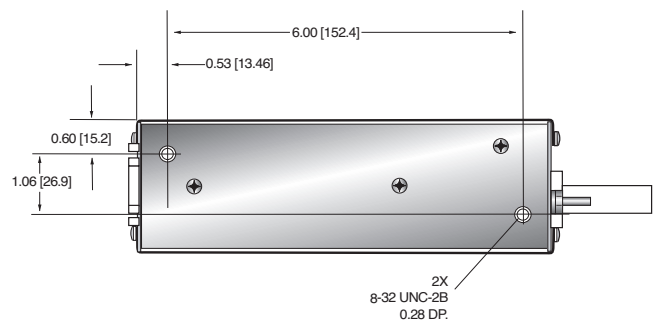

FRONT VIEW



BACK VIEW

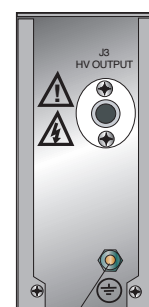



- **Output Voltages from 1kV to 60kV**
- **Arc and Short Circuit Protected**
- **Low Stored Energy**
- **Test Points for Output Current and Voltage**
- **Enable/Inhibit Control of Output**
- **OEM Customization Available**

www.spellmanhv.com/manuals/SMS

Spellman's SMS Series of 60 watt high voltage power supplies are based on a proprietary resonant fly back power conversion topology that provides over 80% efficiency. These fixed polarity modules (specify positive or negative at time of order) feature both voltage and current regulation with automatic crossover, making them ideal for sensitive load applications. The robust design of SMS Series along with comprehensive arc and short circuit protection allow operation in the most demanding environments.

TYPICAL APPLICATIONS

Electrospinning
Hipot Testing
Detector Arrays
Electrophoresis
Cable Testing

SPECIFICATIONS

Input:

+24Vdc \pm 10% @ 4.0A

Output:

10 models from 1kV to 60kV. Positive or negative polarity outputs.

Efficiency:

80 to 85%, typical

Voltage Regulation:

Load: 0.01% of output voltage no load to full load.
Line: \pm 0.01% for \pm 10% change in input voltage.

Current Regulation:

Load: 0.1% of output current from 0 to rated voltage.
Line: 0.05% of rated current over specified input range.

Stability:

0.02% per 8 hours.

Temperature Coefficient:

0.01% per °C, voltage or current regulated.

Ripple:

0.1% p-p of maximum output voltage.

Environmental:

Temperature Range:
Operating: 0°C to 40°C
Storage: -40°C to 85°C

Humidity:
0 to 90%, non-condensing

Dimensions:

3"H x 5"W x 9"D (7.6cm x 12.7cm x 23.0cm).

Weight:

5.25 pounds (2.38kg)

Input Connector:

12 pin AMP Metri-Mate (mating connector and pins provided)

Output Cable:

18" \pm 1" (45.7cm) of UL® approved high voltage wire

Front Panel Ground Connection:

Threaded 8-32 ground stud, nut provided

Regulatory Approvals:

Compliant to EEC EMC Directive. Compliant to EEC Low Voltage Directive. RoHS Compliant.

SMS SELECTION TABLE

Maximum Rating kV	Maximum Rating mA	Model Number
1	60	SMS 1*60
3	20	SMS 3*60
5	12	SMS 5*60
10	6	SMS 10*60
15	4	SMS 15*60
20	3	SMS 20*60
30	2	SMS 30*60
40	1.5	SMS 40*60
50	1.2	SMS 50*60
60	1.0	SMS 60*60

*Specify "P" for positive polarity or "N" for negative polarity.

CONNECTOR 12 PIN

PIN	SIGNAL	PARAMETERS
1	Power Ground	+24Vdc Return
2	+24Vdc Input	+24Vdc @ 3.5 amps, maximum
3	High Voltage Enable/Inhibit	Open = HV OFF, Ground = HV ON
4	Voltage Test Point	0 to 10Vdc = 0 to 100% of rated output
5	Current Test Point	0 to 10Vdc = 0 to 100% of rated output
6	Voltage Programming	0 to 10Vdc = 0 to 100% of rated output
7	Current Programming	0 to 10Vdc = 0 to 100% of rated output
8	+10Vdc Reference	+10Vdc @ 1mA maximum
9	Signal Ground	Signal Ground
10	Spare	No Connection
11	Spare	No Connection
12	Spare	No Connection

DIMENSIONS: in.[mm]

SIDE VIEW

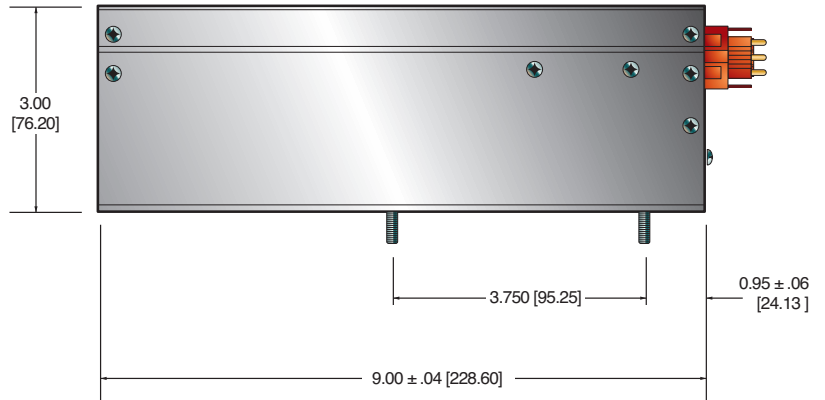

TOP VIEW

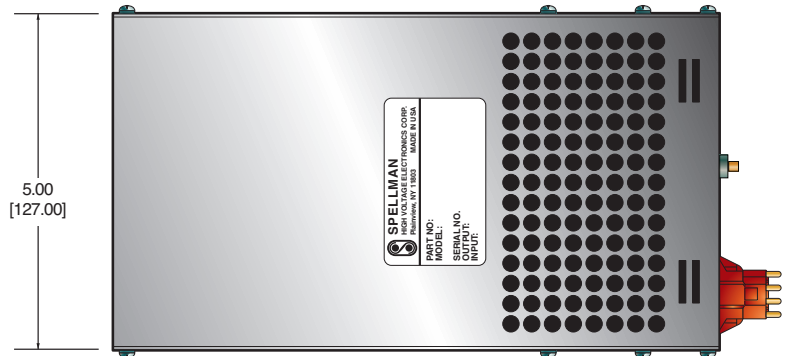

BACK VIEW

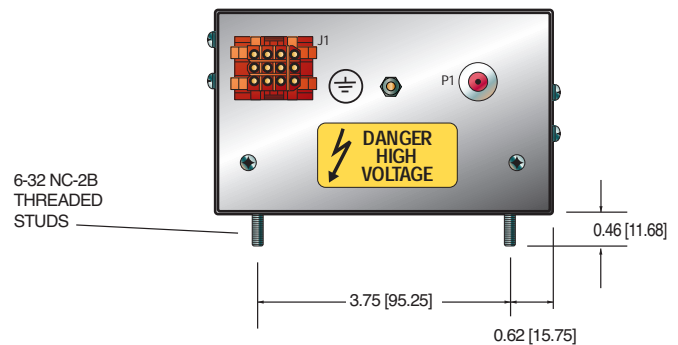



- **5 Voltage Ranges from 8kV to 20kV, Fixed Negative or Positive Polarity**
- **Available Output Power Increments of 60 and 125 Watts**
- **Voltage/Current Regulation with Automatic Crossover Control**
- **Voltage and Current Monitor Signals**
- **Fully Arc and Short Circuit Protected**
- **UL Recognized**
- **CE Listed and RoHS Compliant**

www.spellmanhv.com/manuals/UMW

Form, Fit and Function Usability:

Spellman's UMW Series of high voltage modules provides users with a form, fit and function replacement for presently available commercially made units, while providing superior features and benefits at competitive pricing. Utilizing proprietary power conversion technology, unique high voltage packaging, and Spellman's unmatched encapsulation techniques, these SMT based high voltage modules provide improved performance and easier system integration at a lower cost when compared to the competition.

Advanced Power Conversion Topology:

UMW converters use a proprietary resonant power conversion topology providing exceptional efficiency and inherent low noise and ripple outputs. Radiated emissions are dramatically reduced compared to conventional switching topologies, effectively minimizing or even eliminating the need to shield the unit from adjacent circuitry.

The high voltage output is generated through the use of a ferrite core high voltage step up transformer which feeds the high voltage output circuitry. Units utilize an appropriate arrangement of low capacitance Cockcroft-Walton voltage multiplier stages to obtain the specified high voltage output.

Due to the fixed, high frequency conversion rate of the converter, the output capacitance is small resulting in minimal stored energy and fast rise times. Through the use of generously rated surge limiting resistors and a fast acting current loop, all units are fully arc and short circuit protected.

Control and Regulation:

The actual output voltage generated is sampled via a high impedance divider to create a voltage feedback signal. A current feedback signal is created via a current sense resistor being placed in the low end return of the high voltage output circuitry. These two accurate ground referenced feedback signals are used to precisely regulate and control the units output. These accurate and calibrated signals are also used for external monitoring purposes.

Due to the UMW's unique converter topology it can provide full current into low impedance loads or even a short circuit. Standard units limit at 103% of maximum rated output current.

Standard User Interface:

The Spellman UMW Series offers a standard customer interface that provides current programming capability and positive polarity, buffered, low output impedance voltage and current monitor signals (0 to +4.64Vdc equals 0 to full scale rated). A voltage programming input is provided where 0 to +4.64Vdc equals 0 to 100% of rated voltage.

Current programmability allows the user to set where the unit will current limit, anywhere from 0 to 100% of maximum rated current. This feature is beneficial where less than full output current is desired, like in the case of protecting a sensitive load.

The buffered low impedance voltage and current monitor signals can drive external circuitry directly, while minimizing loading and pickup effects. These feature save the user the expense and implementation of external interface buffering circuitry while improving overall signal integrity.

Mechanical and Environmental Considerations:

The UMW Series are modular sheet metal enclosed converters measuring 8.00" X 4.50" X 1.075" (203mm X 114mm X 27mm). All units are encapsulated using a propriety silicon based potting material which is considerably lighter in weight than epoxy encapsulation techniques. Physical mounting of the unit is accomplished via the use of bottom mounted studs or threaded blind inserts, dependent upon model ordered.

SPECIFICATIONS

Input Voltage:

24Vdc

Normal Voltage Range:

23Vdc to 30Vdc

Derated Voltage Range:

11Vdc to 30Vdc

Input Current: (typical)

Disabled: <40mA
 No load: <600mA
 Full load:
 60 watt units: 3 amps
 125 watt units: 6.2 amps

Voltage Regulation:

Line: <0.01%
 Load: <0.01%

Current Regulation:

Line: <0.01%
 Load: <0.01%

Stability:

0.01% per 8 hours, 0.02% per day after 30 min. warmup

Accuracy:

2% on all programming and monitoring, except I Sense 10%

Temperature Coefficient: (typical)

100ppm/°C

Overshoot:

<0.1% Vp

Environmental:

Temperature Range:
 Operating: -0°C to 65°C case temperature
 Storage: -55°C to 85°C, non operational
 Humidity:
 10% to 90%, non-condensing

Dimensions:

8.00" L X 4.50" W X 1.075" H
 (203mm X 114mm X 27mm)

Weight:

1.75 lbs. (0.79kg)

Regulatory Approvals:

Compliant to EEC EMC Directive. Compliant to EEC Low Voltage Directive. UL/CUL recognized, File E227588. RoHS Compliant.

UMW 60W SELECTION TABLE

Model Number	Output V	Output Current	Ripple(max) %Vp-p	Output Capacitance	Arc Limiting Resistance	I Sense Scaling Full Scale Signal
UMW8*60	0 to 8kV	7.5mA	<1.0 (C load ≥0.05µF)	3553pF	14.1kΩ	1.6V
UMW10*60	0 to 10kV	6mA	<1.0 (C load ≥0.05µF)	3553pF	14.1kΩ	1.47V
UMW12*60	0 to 12kV	5mA	<1.0 (C load ≥0.05µF)	2870pF	30kΩ	1.24V
UMW15*60	0 to 15kV	4mA	<1.0 (C load ≥0.05µF)	2460pF	30kΩ	1.0V
UMW20*60	0 to 20kV	3mA	<1.0 (C load ≥0.01µF)	2460pF	45kΩ	4.61V

UMW 125W SELECTION TABLE

Model Number	Output V	Output Current	Ripple(max) %Vp-p	Output Capacitance	Arc Limiting Resistance	I Sense Scaling Full Scale Signal
UMW8*125	0 to 8kV	15.5mA	<1.0 (C load ≥0.05µF)	7106pF	3kΩ	1.1V
UMW10*125	0 to 10kV	12.5mA	<1.0 (C load ≥0.05µF)	7106pF	3kΩ	1.15V
UMW12*125	0 to 12kV	10.5mA	<1.0 (C load ≥0.05µF)	5740pF	6.6kΩ	1.40V
UMW15*125	0 to 15kV	8.3mA	<1.0 (C load ≥0.05µF)	4920pF	6.6kΩ	1.1V
UMW20*125	0 to 20kV	6.25mA	<1.0 (C load ≥0.01µF)	4920pF	14.1kΩ	9.57V

Grayed text indicates Legacy interface signals.

ORDERING INFORMATION

Voltage	0 to 8kV	8
	0 to 10kV	10
	0 to 12kV	12
	0 to 15kV	15
	0 to 20kV	20
Polarity	Positive	P
	Negative	N
Power	60Watts	60
	125Watts	125
Legacy Interface	Legacy Interface	L

If a high voltage mating connector is required it should be included at time of order. See page 3 for details

ORDERING EXAMPLE

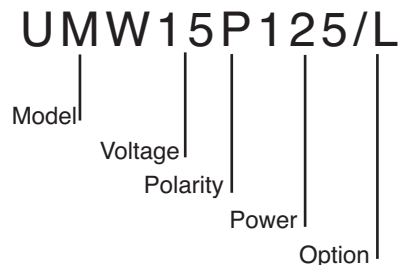

STANDARD INTERFACE

PIN	SIGNAL	PARAMETERS
1	Power Ground Return	+24Vdc power ground return
2	+ Power Input	+24Vdc power input
3	I Sense	See I Sense text and tables for details
4	Enable Input	Low (<0.7V, Isink@1mA)=HV OFF, High (open or >2V)=HV ON
5	Signal Ground	Signal Ground
6	Remote V Adjust	0 to +4.64Vdc = 0 to 100%, Zin >1MΩ
7	+5V Reference Output	+5Vdc ±2%. Zout = 475Ω
8	Power Ground Return	+24Vdc Power Ground Return
9	+ Power Input	+24Vdc Power Input
10	Signature Resistor	Unique identifying resistor connected to ground
11	Remote I Adjust	0 to +4.64Vdc = 0 to 100%, Zin >1MΩ Leave open for preset current limit @103% of rated output current
12	I Monitor	0 to +5Vdc = 0 to 107.5%, Zout <10kΩ
13	V Monitor	0 to +5Vdc = 0 to 107.5%, Zout <10kΩ
14	E Out Monitor	1.00 Volt, 1GΩ/1.1MΩ divider with 10MΩ meter

Interface Connections

Fourteen (14) gold plated 0.025" (0.63mm) square pins that will mate with AMP Mod-U connectors. See mechanical drawing for location and spacing details.

Programming and Monitor Signals

Voltage and current programming is done via positive polarity, high input impedance, 0 to 4.64Vdc signals. Voltage and current monitors are positive polarity, buffered low output impedance 0 to 4.64Vdc signals.

Signature Resistor

A unique identifying signature resistor for each type of unit is connected from Pin 10 to Ground. Details if desired are available upon request.

LEGACY INTERFACE (L OPTION)

PIN	SIGNAL	PARAMETERS
1	Power Ground Return	+24Vdc power ground return
2	+ Power Input	+24Vdc power input
3	I Sense	See I Sense text and tables for details
4	Enable Input	Low (<0.7V, Isink@1mA)=HV OFF, High (open or >2V)=HV ON
5	Signal Ground	Signal Ground
6	Remote Adjust	Positive Polarity Unit: 0 to +4.64Vdc = 0 to 100% rated voltage Zin>1MΩ Negative Polarity Unit: +5Vdc to 0.36Vdc = 0 to 100% rated voltage Zin>1MΩ
7	+5V Reference Output	+5Vdc ±2%. Zout = 475Ω
8	Power Ground Return	+24Vdc Power Ground Return
9	+ Power Input	+24Vdc Power Input
10	Signature Resistor	Unique identifying resistor connected to ground
11	N/C	
12	N/C	
13	N/C	
14	E Out Monitor	1.00 volt/kV, 1GΩ/1.1MΩ divider with 10MΩ meter

I Sense Signal

The polarity of the current monitor signal is opposite of the polarity of the output voltage of the unit that generated it. So a positive output polarity unit creates a negative polarity current monitor signal; while a negative output polarity unit creates a positive polarity current monitoring signal. This signal is clamped to ground internally via a bidirectional 18 volt transient protection device and the signal is made available via a series connected 47kΩ isolation resistor. Internal HV dividers create a small, linear offset voltage on this current monitor signal that can be compensated for.

HIGH VOLTAGE MATING CONNECTOR

KV	CONNECTOR
8	LGH1 SHV P.N. 304781-001
10	
12	
15	
20	LGH1L SHV P.N. 304781-101

Low Voltage Interface Connector

A mating AMP Mod-U interface connector will be provided.

High Voltage Output Mating Connector

An appropriate mating LGH high voltage connector (36" long) will be required. Please see table to left for specific part number.

High Voltage Return

Two gold plated 0.025" (0.63mm) square pins (15 and 16) are provided. These are connected to Power Ground Return.

DIMENSIONS: in.[mm]

**TOP VIEW
UMW UP TO 15KV**

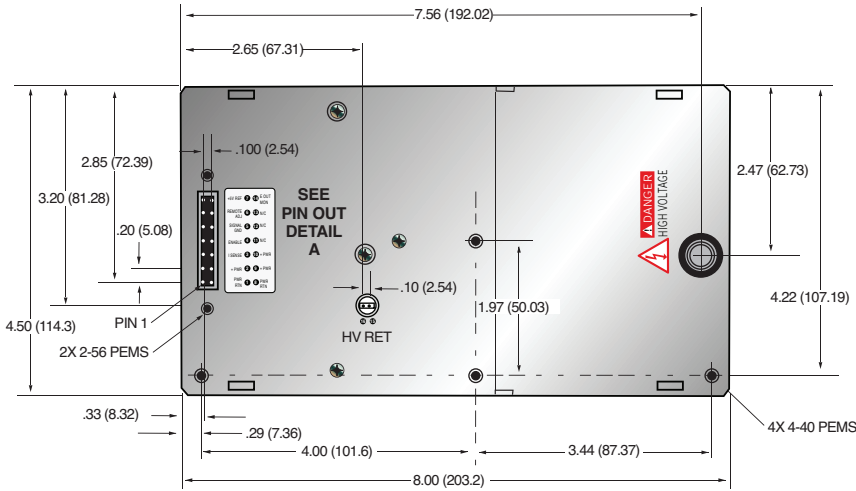

**TOP VIEW
UMW 20KV**

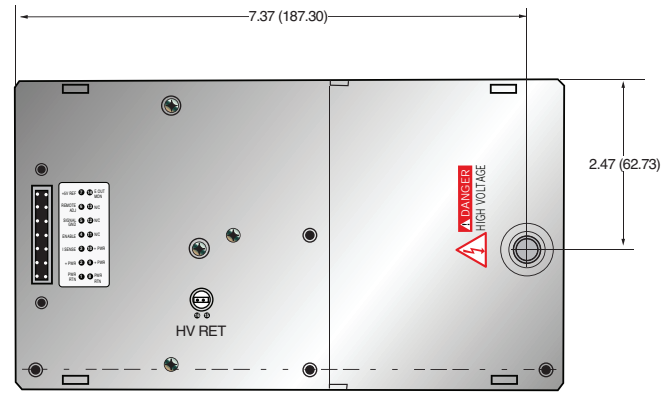

BOTTOM VIEW

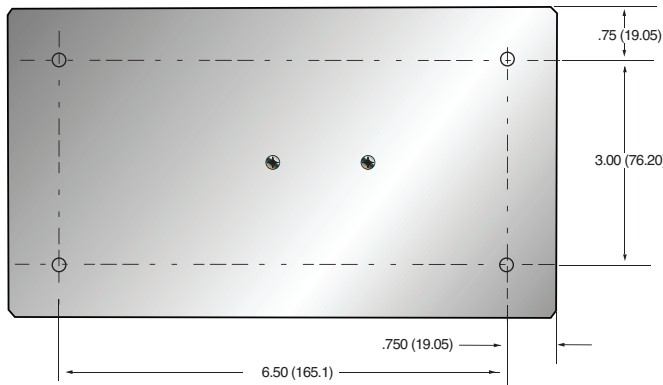

**PIN OUT
DETAIL A
ALL UMW UNITS**

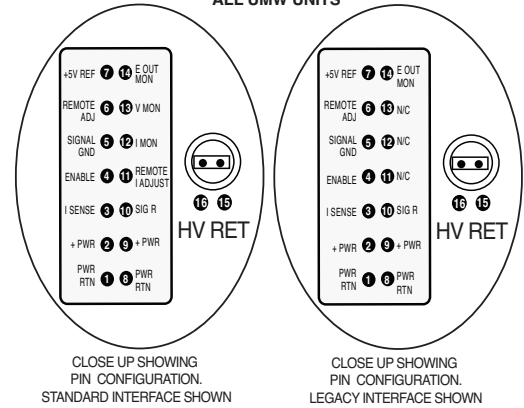

SIDE VIEW

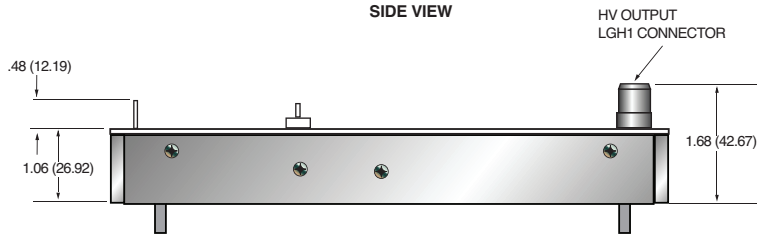

**SIDE VIEW
UMW 20KV**

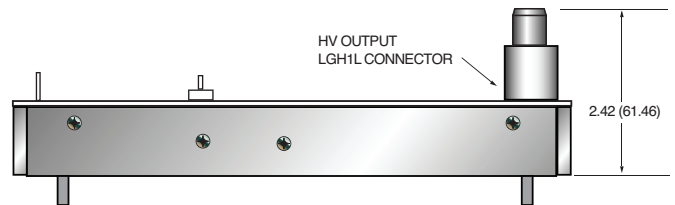

FRONT VIEW

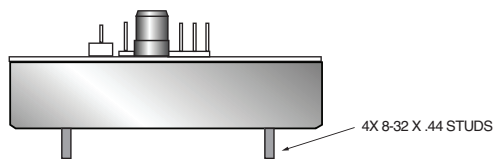

**FRONT VIEW
UMW 20KV**

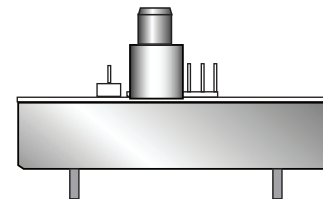



- **Output Voltages from 1kV to 70kV**
- **Arc and Short Circuit Protected**
- **Low Stored Energy**
- **Test Point for Output Current and Voltage**
- **Enable/Inhibit Control of Output**
- **Safety Interlock Circuit**
- **OEM Customization Available**

www.spellmanhv.com/manuals/PCM

Spellman's AC input PCM Series of 120 watt high voltage power supply modules feature a power factor corrected front end, providing 0.99 power factor along with universal input voltage (85Vac to 265Vac) capabilities. These fixed polarity modules (specify positive or negative at time of order) feature both voltage and current regulation with automatic crossover, making them ideal for sensitive load applications. The robust design of PCM Series along with comprehensive arc and short circuit protection allow operation in the most demanding environments.

TYPICAL APPLICATIONS

Electrospinning
Hipot Testing
Detector Arrays
Electrophoresis
Cable Testing

SPECIFICATIONS

Input:

85-265Vac, 47-63Hz @ 1.8A, power factor corrected.
UL® rated for 85-250Vac input for 1kV to 5kV models.

Power Factor (Typical):

FL: 0.99
NL: 0.98

Efficiency:

80 to 85%, typical

Output:

11 models from 1kV to 70kV. Positive or negative polarity outputs, specify at time of order.

Voltage Regulation:

Load: 0.01% of output voltage, no load to full load.
Line: ±0.01% for ±10% change in input voltage.

Current Regulation:

Load: 0.01% of output current from 0 to rated voltage.
Line: 0.01% of rated current over specified input range.

Ripple:

0.1% p-p of maximum output voltage.

Voltage Stability:

0.02% per 8 hours.

Temperature Coefficient:

100ppm per °C, voltage or current regulated.

Environmental:

Operational: 0 to 40°C
Storage: -40°C to +85°C
Humidity: 0 to 90%, non-condensing

Dimensions:

1kV to 50kV: 3.65"H x 5"W x 9"D
(9.27cm x 12.7cm x 22.9cm).
60, 70kV: 3.65"H x 5"W x 11"D
(9.27cm x 12.7cm x 27.9cm).

Weight:

7 pounds (3.18kg)

AC Input Connectors:

IEC320 with mating cable.

Interface Connector:

15 pin D connector.

HV Output Cable:

Spellman Delrin type connector with 36"
(91.4cm) shielded cable.

Front Panel Ground Connection:

Threaded 8-32 ground stud

Regulatory Approvals:

Compliant to EEC EMC Directive. Compliant to EEC Low Voltage Directive. UL/CUL recognized, File E148969 (up to 60kV only). RoHS Compliant.

PCM SELECTION TABLE

Maximum Rating kV	Rating mA	Model Number
1	120	PCM 1*120
3	40	PCM 3*120
5	24	PCM 5*120
10	12	PCM 10*120
15	8	PCM 15*120
20	6	PCM 20*120
30	4	PCM 30*120
40	3	PCM 40*120
50	2.4	PCM 50*120
60	2.0	PCM 60*120
70	1.7	PCM 70*120

*Specify "P" for positive polarity or "N" for negative polarity.

PCM D CONNECTOR 15 PIN

PIN	SIGNAL	PARAMETERS
1	Remote mA Program	0 to 10Vdc = 0 to 100% of rated output
2	Remote kV Program	0 to 10Vdc = 0 to 100% of rated output
3	High Voltage Enable/Inhibit	Open = HV Inhibit, Ground = HV ON
4	mA Monitor	0 to 10Vdc = 0 to 100% of rated output
5	Interlock Return	Connect to pin 6 to close interlock circuit
6	Interlock Out	Connect to pin 5 to close interlock circuit
7	kV Monitor	0 to 10Vdc = 0 to 100% of rated output
8	Local kV Program	Multi-turn front panel pot (screwdriver)
9	Power Supply Fault	0Vdc = No Fault, +15Vdc @ 1mA = Fault
10	+10Vdc Reference	+10Vdc @ 1mA maximum
11	Signal Ground	Signal Ground
12	Spare	No Connection
13	Spare	No Connection
14	Spare	No Connection
15	Local mA Program	Multi-turn front panel pot (screwdriver)

DIMENSIONS: in.[mm]

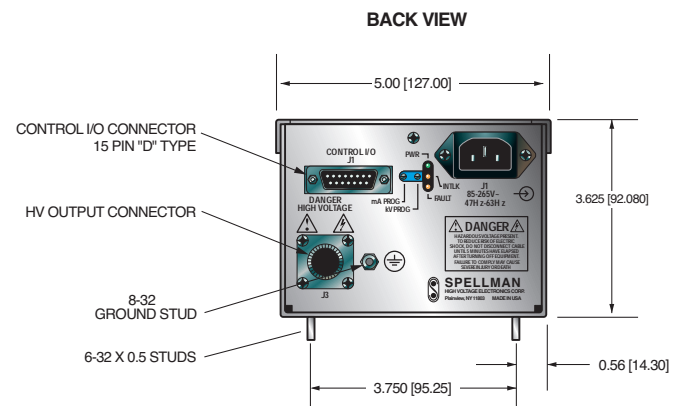
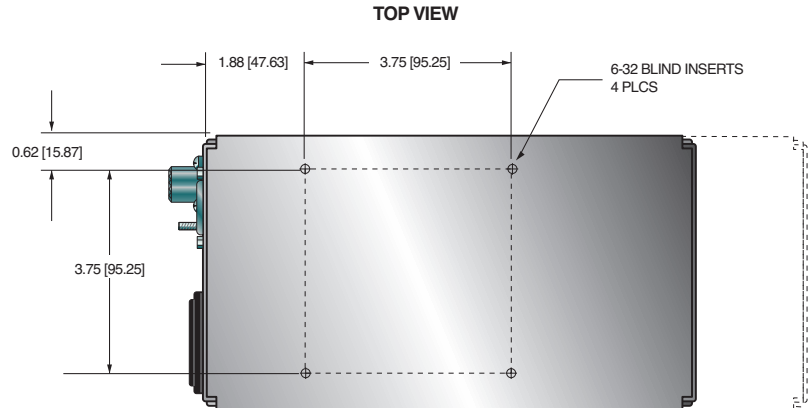
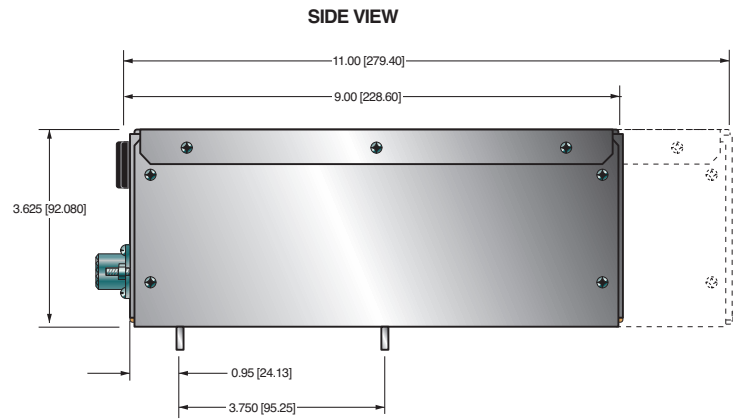



Spellman's PTV Series of modular high voltage power supplies deliver up to 350W of continuous power. A quasi-resonant inverter design provides over 80% efficiency with very fast dynamic response. PTV power supplies incorporate extensive standard features in two power output ranges (200W and 350W) with a wide range of output voltages operating to the most exacting specifications.

TYPICAL APPLICATIONS

Projection Television
X-ray Systems
E-beam Systems
Capacitor Charging systems
CPT/CRT Testing

OPTIONS

FG Floating Ground (50V max)
BPM/S Bipolar Master/Slave
NSS No Slow Start
TP(x) Alternate Test Point Scaling

SPECIFICATIONS

Input:

200W: 115Vac $\pm 10\%$ @ 2.5A, 50/60Hz
350W: 115Vac $\pm 10\%$ @ 4.3A, 50/60Hz

200W: 220Vac $\pm 10\%$ @ 1.3A, 50/60Hz
350W: 220Vac $\pm 10\%$ @ 2.2A, 50/60Hz

Optional:

200W: 100Vac $\pm 10\%$ @ 2.8A, 50/60Hz
350W: 100Vac $\pm 10\%$ @ 4.9A, 50/60Hz

Specify at time of ordering.

Output:

Models from 1kV to 70kV, 200W or 350W. Each model is available in positive or negative polarity outputs.

- **Output Voltages from 1kV to 70kV**
- **Overshoot and Short Circuit Protection**
- **EMI/RFI Input Filter**
- **Test Points for Output Current and Voltage**
- **Internal 10V Reference**
- **Output Inhibit Control Via TTL Signal**
- **OEM Customization Available**

www.spellmanhv.com/manuals/PTV

Voltage Regulation:

Load: 0.01% of output voltage no load to full load.
Line: $\pm 0.01\%$ for a $\pm 10\%$ change in input voltage.

Current Regulation:

Load: 0.01% of output current from 0 to rated voltage.
Line: 0.01% of rated current over specified input range.

Efficiency:

80%, typical.

Ripple:

PTV200: 0.1% p-p of output voltage.
PTV350: 0.2% p-p of output voltage.

Switching Frequency:

45-65kHz, nominal

Temperature:

Operating: 0°C to +40°C.
Storage: -40°C to +85°C.

Voltage Temperature Coefficient:

0.01%/°C

Stability (voltage & current):

0.01%/hr after 1/2 hour warm-up.
0.02% per 8 hours.

Cooling:

200W: Convection cooled.
350W: Fan cooled, rear air intake.

Dimensions:

1-40kV: 3.187" H x 10.75" W x 10" D
(8.1cm x 27.3cm x 25.4cm).

50-70kV: 4.187" H x 10.875" W x 11.812" D
(10.65cm x 27.6cm x 35.1cm).

HV Output:

Flying lead 18" ± 1 " (45.7cm) UL listed.
AMP LGHI connector available for 40kV only.

Power Input Connector:

IEC320.

AC Line Voltage Input Cable:

Length: 8' (2.4m).

Regulatory Approvals:

Compliant to EEC EMC Directive. Compliant to EEC Low Voltage Directive. UL/CUL recognized, File E148969 (up to 5kV only). RoHS compliant.

PTV SELECTION TABLE

200 Watt Model PTV200			350 Watt Model PTV350		
kV	mA	Model Number	kV	mA	Model Number
1	200	PTV1*200	1	350	PTV1*350
3	70	PTV3*200	3	117	PTV3*350
5	40	PTV5*200	5	70	PTV5*350
10	20	PTV10*200	10	35	PTV10*350
15	14	PTV15*200	15	23	PTV15*350
20	10	PTV20*200	20	18	PTV20*350
25	8	PTV25*200	25	14	PTV25*350
30	7	PTV30*200	30	12	PTV30*350
40	5	PTV40*200	40	9	PTV40*350
50	4	PTV50*200	50	7	PTV50*350
60	3.3	PTV60*200	60	5.8	PTV60*350
70	2.85	PTV70*200	70	5.0	PTV70*350

*Specify "P" for positive polarity or "N" for negative polarity.

INTERFACE CONNECTOR 9 PIN

PIN	SIGNAL	PARAMETERS
1	+10Vdc Reference	+10Vdc @ 1mA, maximum
2	Current Program	0 to 10Vdc = 0 to 100% rated output, Z _{in} = 10MΩ
3	Voltage Monitor	0 to 10Vdc = 0 to 100% rated output, Z _{out} = 10kΩ
4	Voltage Program	0 to 10Vdc = 0 to 100% rated output, Z _{in} = 10MΩ
5	Common Ground	Power Ground
6	Current Monitor	0 to 10Vdc = 0 to 100% rated output, Z _{out} = 10kΩ
7	Enable/Inhibit	Ground = Inhibit, Open = HV ON
8	OVP Indicator	Collector w/1kΩ pull up to +5Vdc, transistor on = OVP
9	Signal Return	Signal Return

DIMENSIONS: in.[mm]

TOP VIEW

FOR 350W UNIT ONLY

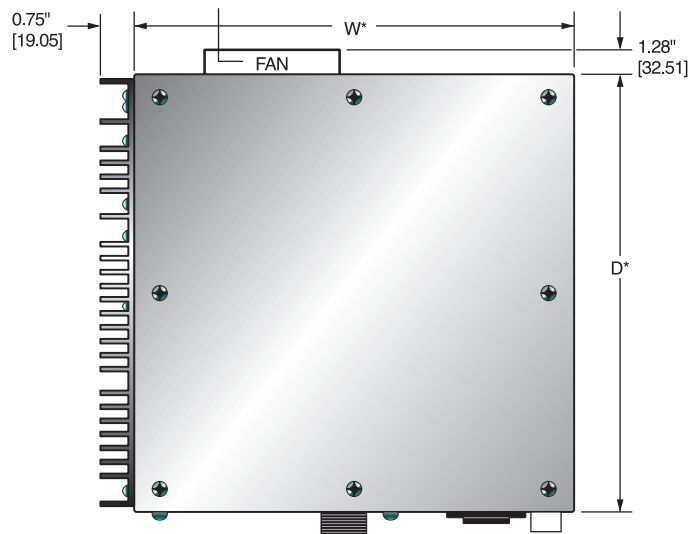

BACK VIEW

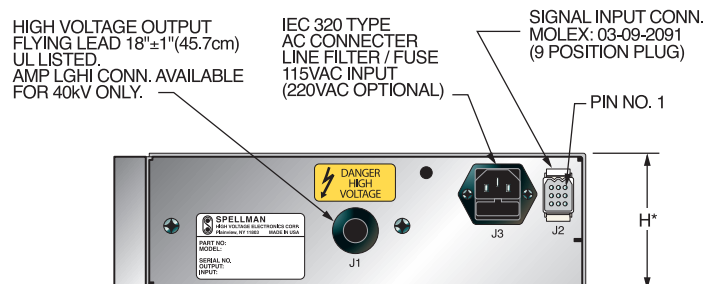

*See Specification for H, W, D Dimensions.

SIDE VIEW

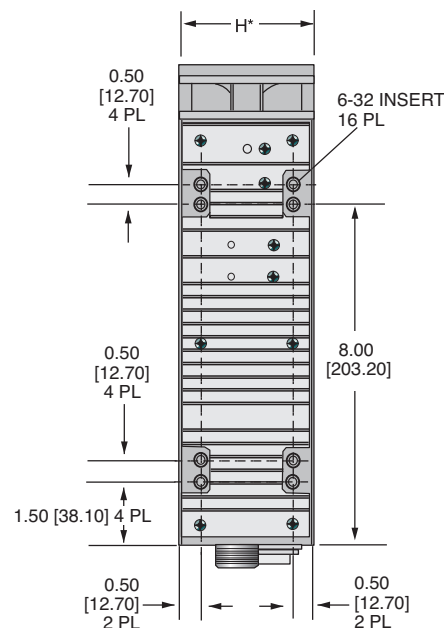



- **Compact & Lightweight**
- **Models from 1kV-160kV, 300W, 600W AND 1200W**
- **Universal Input, Power Factor Corrected**
- **Low Cost Modular Design**
- **Standard Digital Interfaces: USB, Ethernet and RS-232**
- **CE Compliant, UL Recognized**

www.spellmanhv.com/manuals/SLM

Spellman's SLM Series of high voltage modules are designed for OEM applications up to 160kV at 1200 watts. Its universal input, small package size and choice of three standard digital interfaces simplifies integrating the SLM into your system design. Models are available in either positive or negative polarity. The SLM is fully arc and short protected. Excellent regulation specifications are provided along with outstanding stability performance.

TYPICAL APPLICATIONS

- Capacitor Charging
- HiPot Testing
- CRT Testing
- Electrostatics
- E Beam Systems
- CW Lasers

FIRMWARE CONFIGURATIONS

STANDARD BASED FEATURES

- AOL** Adjustable Overload Trip
- AT** Arc Trip
- NAD** No Arc Detect
- NSS** No Slow Start
- PSS** Programmable Slow Start
- RFR** Remote Fault Reset
- RMI** Remote Mode Indicators
- ROV** Remote Overvoltage Adjust

SPECIFICATIONS

Input Voltage:

- Power factor corrected input, ≥ 0.98
- 90-264Vac: 47-63Hz @ 4.0A for 300 watt units
- 180-264Vac: 47-63Hz @ 4.0A for 600 watt units
- 47-63Hz @ 8.0A for 1200 watt units

Output Voltage:

12 models—1kV to 160kV

Output Polarity:

Negative or positive, specify at time of order

Local Indicators:

Arc, HV On, Temp Error, OVP, I Mode
Power On, OC, Reg Error

Power:

3 power ranges available—300, 600 and 1200 watts.
Other power levels available on special order.

Voltage Regulation:

- $\leq 0.01\%$ of rated output voltage over specified input voltage range
- $\leq 0.01\%$ of rated output voltage for a full load change

Current Regulation:

- $\leq 0.01\%$ of rated output current over specified input voltage range
- $\leq 0.01\%$ of rated output current for a $\pm 100\mu\text{A}$ for a full voltage change

Ripple:

- $\leq 0.2\%$ rms of maximum rated voltage, measured with a 10 foot long HV cable

Stability:

- $\leq 50\text{ppm/hr}$ after a 2 hour warm up

Temperature Coefficient:

- $\leq 100\text{ppm per degree C}$

Environmental:

- Temperature Range:
 - Operating: 0°C to 40°C
 - Storage: -40°C to 85°C
- Humidity:
 - 20% to 85% RH, non-condensing.

Control Interface

Local Interface:

Potentiometers are provided to adjust voltage and current.

Remote Interface:

USB, Ethernet and RS-232 are standard, implemented with 12 bits of resolution. All digital monitors have an accuracy specification of 2%.

Control Software:

A VB GUI will be provided for RS-232/USB, the Ethernet interface will have an embedded applet for control.

HV Control Enable/Interlock:

A dry contact, hardware based interlock is provided for remote mode. In local mode this I/O is the enable.

Monitor Signals:

Voltage and current monitor signals are scaled 0-10Vdc equals 0-100% of full scale, accuracy is 1%.

Dimensions:

- 300/600 watts: 4.75" H X 6" W X 12" D
(120.65mm x 152.4mm x 304.8mm)
- 1200 watts: 4.75" H X 12" W X 12" D
(120.65mm x 304.8mm x 304.8mm)
- 160kV: 10.5" H X 19" W X 21.5" D
(266.7mm x 482.6mm x 546.1mm)

Weight:

- 300/600 watts: 14 pounds (6.35kg)
- 1200 watts: 26 pounds (11.8kg)
- 160kV: 142 pounds (64.4kg)

Cooling:

Forced air

Input Line Connector:

IEC320 cord set with integrated EMI filter

Output Cable:

1-70kV units:

A detachable 10' (3.3m) long shielded HV cable is provided.

160kV units:

R24 connector. Mating HV cable not provided

Regulatory Approvals:

Compliant to 204/108/EC, the EMC Directive and 2006/95/EC, the Low Voltage Directive. UL/CUL recognized, File 227588. RoHS compliant.

SLM SELECTION TABLE- 300W

300 Watt		
kV	mA	Model
1	300	SLM1*300
3	100	SLM3*300
5	60	SLM5*300
10	30	SLM10*300
15	20	SLM15*300
20	15	SLM20*300
30	10	SLM30*300
40	7.5	SLM40*300
50	6	SLM50*300
60	5	SLM60*300
70	4.28	SLM70*300

*Specify "P" for positive polarity or "N" for negative polarity

SLM SELECTION TABLE- 600W

600 Watt		
kV	mA	Model
1	600	SLM1*600
3	200	SLM3*600
5	120	SLM5*600
10	60	SLM10*600
15	40	SLM15*600
20	30	SLM20*600
30	20	SLM30*600
40	15	SLM40*600
50	12	SLM50*600
60	10	SLM60*600
70	8.56	SLM70*600

*Specify "P" for positive polarity or "N" for negative polarity

SLM SELECTION TABLE- 1200W

1200 Watt		
kV	mA	Model
1	1200	SLM1*1200
3	400	SLM3*1200
5	240	SLM5*1200
10	120	SLM10*1200
15	80	SLM15*1200
20	60	SLM20*1200
30	40	SLM30*1200
40	30	SLM40*1200
50	24	SLM50*1200
60	20	SLM60*1200
70	17.14	SLM70*1200
160	7.5	SLM160*1200

*Specify "P" for positive polarity or "N" for negative polarity

SLM ANALOG INTERFACE— J2 15 PIN MALE D CONNECTOR

PIN	SIGNAL	SIGNAL PARAMETERS
1	Power Supply Fault	Open Collector, 35V @ 10mA Maximum
2	Current Program In	0 to 10V=0 to 100% Rated Output, Zin=10MΩ
3	Voltage Program In	0 to 10V=0 to 100% Rated Output, Zin=10MΩ
4	NC	No Connection
5	Local Voltage Prog.	Multi-turn front panel potentiometer
6	NC	No Connection
7	Local Current Prog.	Multi-turn front panel potentiometer
8	Voltage Monitor	0 to 10V=0 to 100% Rated Output, Zout=4.99k, 1%
9	Signal Ground	Ground
10	Current Monitor	0 to 10V=0 to 100% Rated Output, Zout=4.99k, 1%
11	HV Enable Input	Connect to Pin 12 to HV Enable Supply
12	HV Enable Output	+15V @ Open, ≤15mA @ Closed
13	NC	No Connection
14	HV On Output Signal	Open Collector, 35V @10mA Maximum
15	Spare	No Connection

RS-232 DIGITAL INTERFACE— J3 9 PIN FEMALE D CONNECTOR

PIN	SIGNAL	SIGNAL PARAMETERS
1	NC	No Connection
2	TX out	Transmit Data
3	RX in	Receive Data
4	NC	No Connection
5	SGND	Ground
6	NC	No Connection
7	NC	No Connection
8	NC	No Connection
9	NC	No Connection

USB DIGITAL INTERFACE— J4 4 PIN USB "B" CONNECTOR

PIN	SIGNAL	SIGNAL PARAMETERS
1	VBUS	+5 Vdc
2	D-	Data -
3	D+	Data +
4	GND	Ground

ETHERNET DIGITAL INTERFACE— J5 8 PIN RJ45 CONNECTOR

PIN	SIGNAL	SIGNAL PARAMETERS
1	TX+	Transmit Data +
2	TX-	Transmit Data -
3	RX+	Receive Data +
4	NC	No Connection
5	NC	No Connection
6	RX-	Receive Data -
7	NC	No Connection
8	NC	No Connection

R24 HV CONNECTOR PINOUT J6 HIGH VOLTAGE OUTPUT (160kV)

PIN	OUTPUT CONNECTION
C (common)	High Voltage Output
S (small)	High Voltage Output
L (large)	High Voltage Output

DIMENSIONS: in.[mm]

300/600 Watt

BOTTOM VIEW

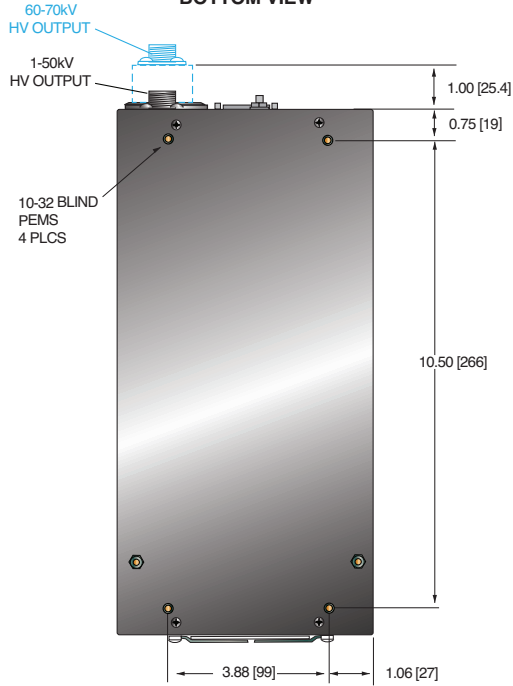

1200 Watt

BOTTOM VIEW

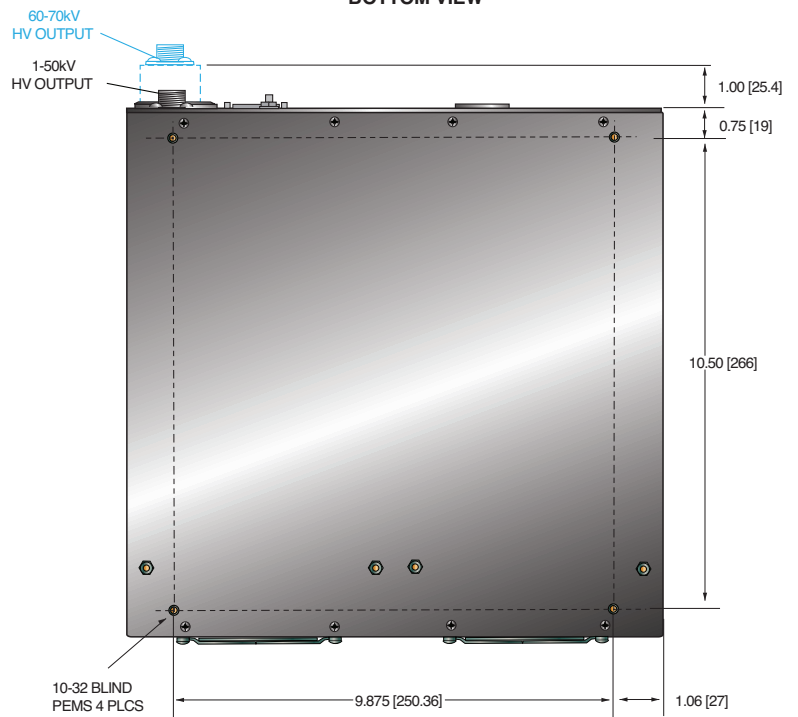

FRONT VIEW

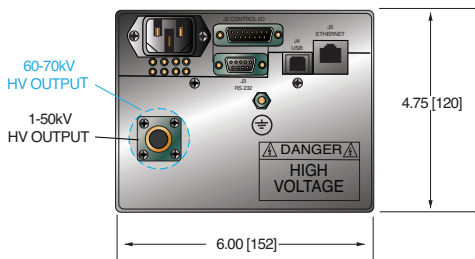

FRONT VIEW

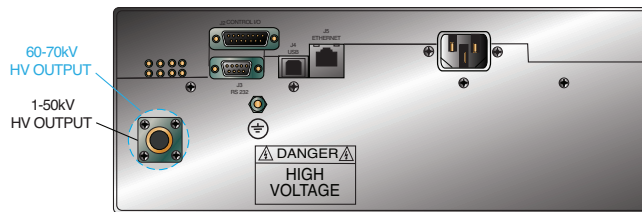

SIDE VIEW

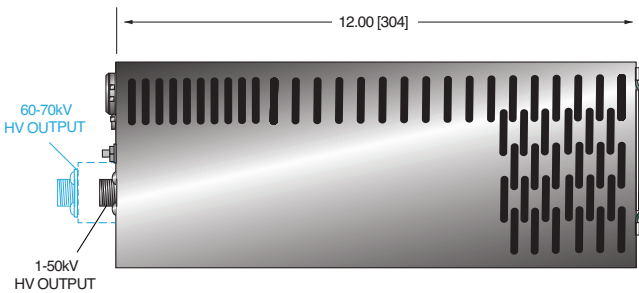

SIDE VIEW

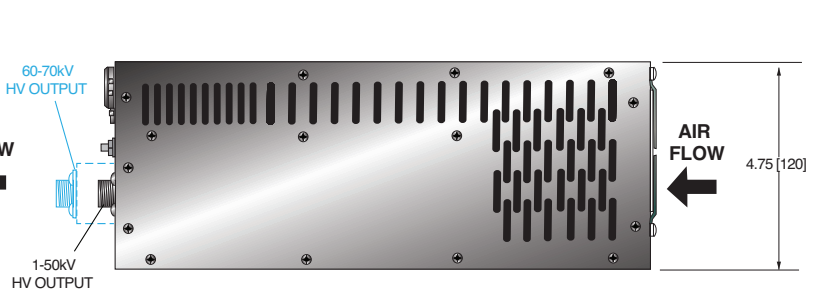

DIMENSIONS: in. [mm]

160kV

TOP VIEW

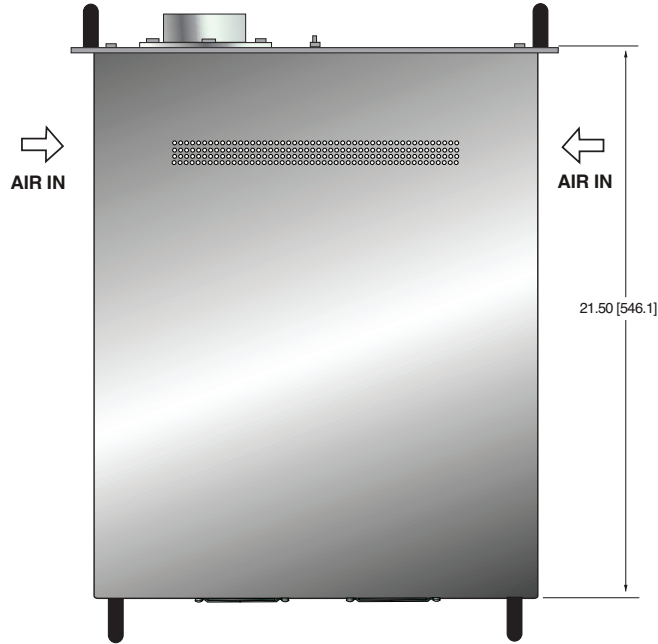

FRONT VIEW

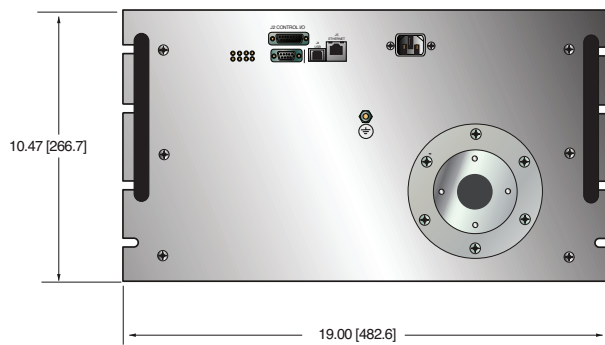

SIDE VIEW

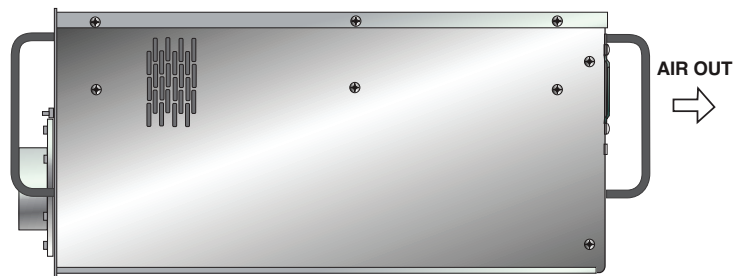

NOW AVAILABLE: Spellman's Quick Delivery Program

- **Very Compact and Lightweight**
- **Voltage Range from 1kV to 130kV**
- **Reversible Polarity Standard up to 8kV**
- **Extensive Analog and Digital Interface**
- **Optional VFD Front Panel/Ethernet Interface**
- **Arc Quench/Arc Count/Arc Trip**
- **OEM Customization Available**

www.spellmanhv.com/manuals/SL

Ripple:

0.1% p-p +1Vrms.

Temperature Coefficient:

100ppm/°C voltage or current regulated. Higher stability is available on special order.

Environmental:

Temperature Range:

Operating: 0°C to 50°C.

Storage: -40°C to 85°C.

Humidity:

10 to 90% relative humidity, non-condensing

Stability:

100ppm/hour after 1/2 hour warm-up for both voltage and current regulation.

Metering:

Digital voltage and current meters, 3 1/2 digit ±1 least significant digit.

Output Cable:

10' (3.05m) of shielded high voltage cable removable at the rear panel.

AC Line Input Cable:

10 to 300W: IEC320 Cord Set, 6' (1.83m)

600 to 1200W: 3-conductor, 12AWG, 6' (1.83m) cable permanently attached to unit.

Dimensions:

10W – 300W: 1 3/4" H(1U) x 19" W x 19" D** (4.45cm x 48.3cm x 48.3cm).

600W – 1200W: 3 1/2" H(2U) x 19" W x 19" D** (8.9cm x 48.3cm x 48.3cm).

**Depth becomes 24" (60.7cm) for 80 to 130kV ranges.

Weight:

17 to 30lbs (7.7 to 14kg) depending on model.

Regulatory Approvals:

Compliant to EEC EMC Directive and EEC Low Voltage Directive. RoHS Compliant.

Electronic Component (Power Source)

SL series is intended for installation as a component of a system.

It is designed to meet CE standards, with conditions of acceptance often being: customer provided enclosure mounting, EMC filtering, and appropriate protection, and isolation devices. The SL series is not intended to be operated by end users as a stand-alone device. The SL series power supply can only be fully assessed when installed within a system, and as a component part within that system.



SL 10W-300W

SL 600W-1200W



Spellman's SL Series of high voltage power supplies are designed to meet uncompromising performance standards in a minimum of space. Their circuitry includes a resonant high frequency inverter with proprietary control which provides fault-free operation in extreme transient and arcing environments with greater than 85% efficiency. These full featured supplies are available in a wide range of outputs with many options.

TYPICAL APPLICATIONS

- | | |
|------------------|--------------------|
| Analytical X-ray | Capacitor Charging |
| Electrostatics | Hipot Testing |
| E-Beam Systems | General Laboratory |

OPTIONS

See page 5 for options and descriptions

SPECIFICATIONS

Status Indicators:

Voltage and Current Control Mode, Interlock Open/Closed, High Voltage Inhibit, Overcurrent and Overvoltage, Arc, Regulation Error, Overtemperature, Over Power (optional).

Input:

115Vac or 220Vac±10%, 50/60Hz. Specify with order. 1200W model available in 200/220Vac only. For input current see table on page 2.

Output:

Models available from 1kV to 130kV. Each model is available in positive, negative or reversible polarity output.

Front Panel Controls:

Voltage and current are continuously adjustable by ten-turn potentiometers with lockable counting dials, ON/OFF circuit breaker/lamp, high voltage ON switch/indicator and high voltage OFF switch/indicator.

Voltage Regulation:

Load: 0.005% of maximum voltage +500mV for full load change.

Line: ±0.005% of full voltage +500mV over specified input range

Current Regulation:

Load: 0.01% of maximum current ±100µA for full voltage change.

Line: ±0.005% of maximum current for a ±10% input line change.



Quick Delivery Program

In the selection tables to the right, SL models shown in **RED** are available via Spellman's Quick Delivery Program. Please contact Spellman sales for details.

How To Order:

Sample model number: SL80PN1200/NSS/DPM4
 SL series unit, 80kV maximum output voltage, reversible polarity output, 1200 watts, no slow start, 4.5 digit panel meters

There may be some restrictions on multiple option combinations. Please contact our sales department for more details.

*Specify "P" for positive, "N" for negative, or "PN" for reversible polarity. Higher voltage models available on special order.

SL INPUT CURRENT

MODEL	115Vac	220Vac
10 watt	<1A	<1A
30 watt	<1A	<1A
60 watt	1.1A	<1A
150 watt	2.8A	1.5A
300 watt	5.6A	3A
600 watt	11.1A	6A
1200 watt	n/a	12A

The input current numbers above are worse case assuming the power supply is being operated at maximum power and low line conditions, taking efficiency and power factor into account.

SL TERMINAL BLOCK 26 PIN

PIN	SIGNAL	SIGNAL PARAMETERS
1	Power Supply Common	Signal Ground
2	External Inhibit	Ground=Inhibit, Open=HV On
3	External Interlock	+15V at Open, <15mA at Closed
4	External Interlock Return	Return for Interlock
5	Current Monitor	0 to 10V=0 to 100% Rated Output
6	kV Test Point	0 to 10V=0 to 100% Rated Output
7	+10Vdc Reference	+10Vdc, 1mA Max
8	Remote Current Program In	0 to 10V=0 to 100% Rated Output
9	Local Current Program Out	Front Panel Program Voltage
10	Remote Voltage Program In	0 to 10V=0 to 100% Rated Output
11	Local Voltage Program Out	Front Panel Program Voltage
12	Power Monitor	0 to 10V=0 to 100% Rated Output
13	Remote Power Program In (Optional)	
14	Local HV Off Out	+15V at Open, <25mA at Closed
15	HV Off	Connect to HV OFF for FP Operation
16	Remote HV On	+15V, 10mA Max=HV Off
17	Remote HV Off Indicator	0=HV On, +15V, 10mA Max=HV Off
18	Remote HV On Indicator	0=HV Off, +15V, 10mA Max=HV On
19	Remote Voltage Mode	Open Collector 35V Max, 10mA Max On=Active
20	Remote Current Mode	
21	Remote Power Mode	
22	Remote PS Fault	0=Fault, +15V, 0.1mA Max=No Fault
23	+15V Output	+15V, 100mA Max
24	Power Supply Common	Signal Ground
25	Spare	Spare
26	Shield Return	Chassis Ground

SL SELECTION TABLE- 10W, 30W, 60W 1.75" (1U)

kV	10 Watt		30 Watt		60 Watt	
	mA	Model	mA	Model	mA	Model
1	10	SL1PN10	30	SL1PN30	60	SL1PN60
2	5	SL2PN10	15	SL2PN30	30	SL2PN60
3	3.3	SL3PN10	10	SL3PN30	20	SL3PN60
6	1.7	SL6PN10	5	SL6PN30	10	SL6PN60
8	1.25	SL8PN10	3.75	SL8PN30	7.5	SL8PN60
10	1.0	SL10*10	3	SL10*30	6	SL10*60
15	0.67	SL15*10	2	SL15*30	4	SL15*60
20	0.50	SL20*10	1.5	SL20*30	3	SL20*60
30	0.33	SL30*10	1.0	SL30*30	2	SL30*60
40	0.25	SL40*10	0.75	SL40*30	1.5	SL40*60
50	0.20	SL50*10	0.60	SL50*30	1.2	SL50*60
60	0.17	SL60*10	0.50	SL60*30	1.0	SL60*60
70	0.14	SL70*10	0.43	SL70*30	0.85	SL70*60
80	0.13	SL80*10	0.38	SL80*30	0.75	SL80*60
100	0.10	SL100*10	0.30	SL100*30	0.60	SL100*60
120	0.10	SL120*10	0.25	SL120*30	0.50	SL120*60
130	0.10	SL130*10	0.25	SL130*30	0.46	SL130*60

SL SELECTION TABLE- 150W, 300W 1.75" (1U)

kV	150 Watt		300 Watt	
	mA	Model	mA	Model
1	150	SL1PN150	300	SL1PN300
2	75	SL2PN150	150	SL2PN300
3	50	SL3PN150	100	SL3PN300
6	25	SL6PN150	50	SL6PN300
8	18.75	SL8PN150	37.5	SL8PN300
10	15	SL10*150	30	SL10*300
15	10	SL15*150	20	SL15*300
20	7.5	SL20*150	15	SL20*300
30	5.0	SL30*150	10	SL30*300
40	3.75	SL40*150	7.5	SL40*300
50	3.00	SL50*150	6.0	SL50*300
60	2.50	SL60*150	5.0	SL60*300
70	2.1	SL70*150	4.28	SL70*300
80	1.90	SL80*150	3.75	SL80*300
100	1.50	SL100*150	3.00	SL100*300
120	1.25	SL120*150	2.50	SL120*300
130	1.15	SL130*150	2.30	SL130*300

SL SELECTION TABLE- 600W, 1200W 3.50" (2U)

kV	600 Watt		1200 Watt	
	mA	Model	mA	Model
1	600	SL1PN600	1200	SL1PN1200
2	300	SL2PN600	600	SL2PN1200
3	200	SL3PN600	400	SL3PN1200
6	100	SL6PN600	200	SL6PN1200
8	75	SL8PN600	150	SL8PN1200
10	60	SL10*600	120	SL10*1200
15	40	SL15*600	80	SL15*1200
20	30	SL20*600	60	SL20*1200
30	20	SL30*600	40	SL30*1200
40	15	SL40*600	30	SL40*1200
50	12	SL50*600	24	SL50*1200
60	10	SL60*600	20	SL60*1200
70	8.6	SL70*600	17	SL70*1200
80	7.5	SL80*600	15	SL80*1200
100	6.0	SL100*600	12	SL100*1200
120	5.0	SL120*600	10	SL120*1200
130	4.6	SL130*600	9.2	SL130*1200

DIMENSIONS: in.[mm]

10W-300W

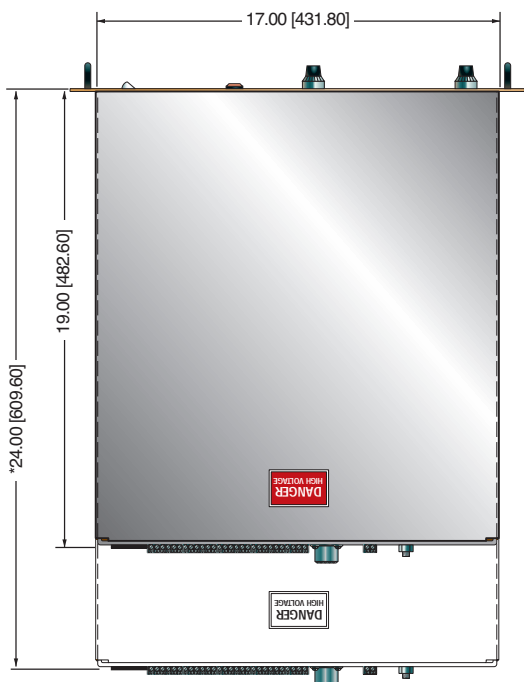
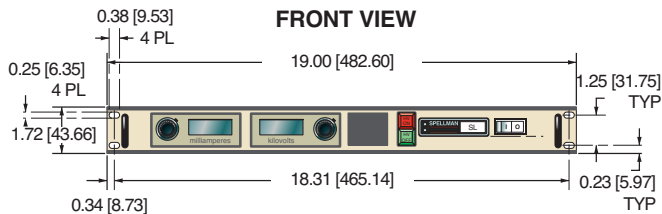

BACK VIEW

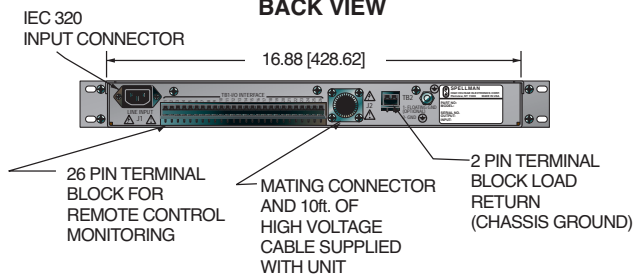

600W-1200W

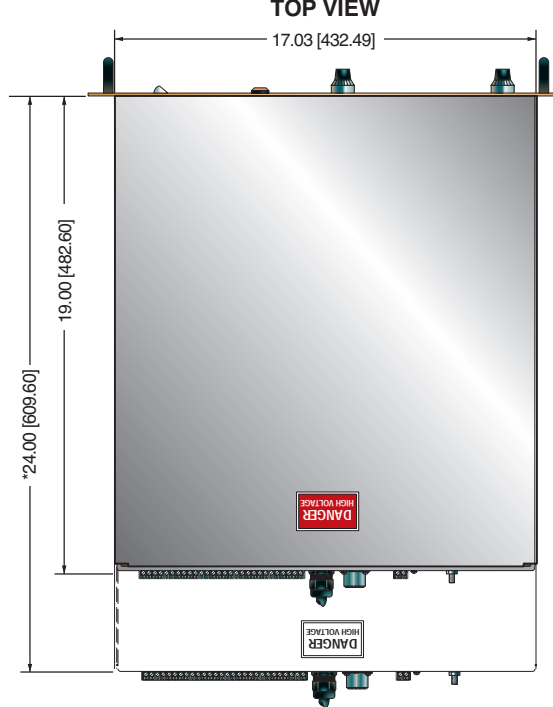
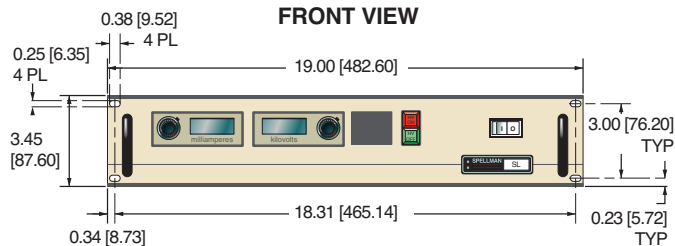

BACK VIEW

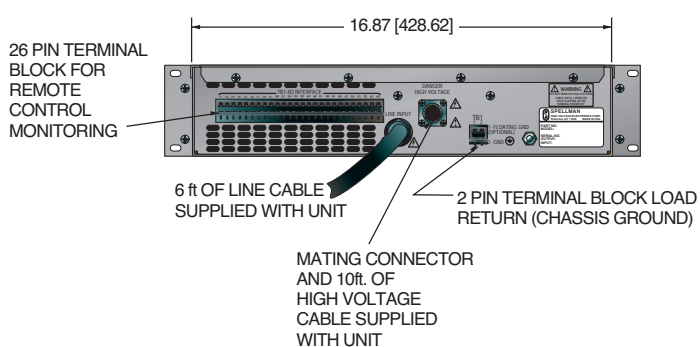

* Depth becomes 24" [609.60] for 80kV to 130kV range.



eSL OPTION



The eSL Option provides a vacuum fluorescent front panel display and Ethernet connectivity. Both the 1U (1.75") and 2U (3.5") SL product offerings are available with the eSL Option. Using the front panel local controls the main menu has the following features:

Local/Remote Control

Allows operation from either the local front panel or remotely via the Ethernet Category 5 connector.

Features Menu

Allows control over Adjustable Overload Trip and Slow Start features.

Tutorial Menu

Provides information on how to use the local front panel interface.

Diagnostics Menu

Provides information on the revisions of the hardware, firmware and IP address. Additionally the Diagnostics Menu provides information on the status of the internal low voltage housekeeping power supply voltages.

eSL Option power supplies can still be fully controlled via the SL's comprehensive remote analog interface, so these units are fully backwards compatible with standard SL power supplies.

Typical Front Panel Screens

Model Number



Standby



HV ON



Digital Interface

A front panel accessible Category 5 connector provides Ethernet connectivity. Spellman provides a basic demo GUI for convenience of the user, but most customers implement their own software.

About Screen

DSP part number, DSP revision, GUI part number, GUI revision, Command set part number, Command set revision

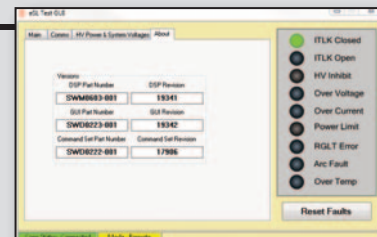

Coms Screen

Communications, IP address, IP port

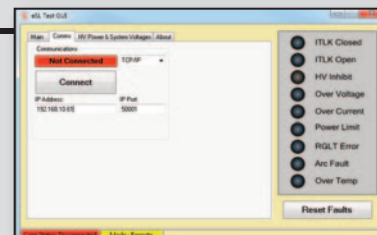

HV Power and System Voltages Screen

HV power (watts) +24V, +15V, +10V, +5V, +3.3V

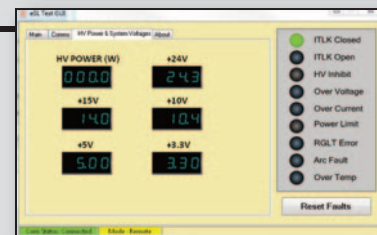

User Configuration Screen

Slow Start – kV, Slow Start – mA, Adjustable Over Load (AOL), Arc Control, Fault Indicators

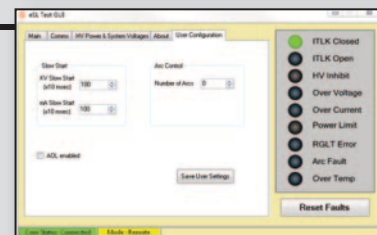

Main Screen

kV Setpoint, kV Readback, mA Setpoint, mA Readback, HV OFF Button, HV ON Button, Arc Counter, System Diagnostics, Reset Faults Button

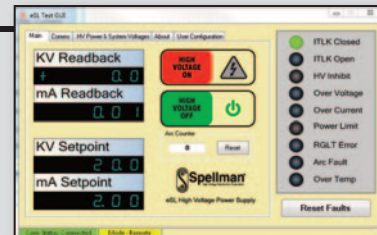

SL SERIES OPTIONS

- AOL*** *Adjustable Overload Trip*
A control board jumper is moved to make the power supply shut down if it ever operates in current mode. This allows the user to set the current programming level as a trip point that will turn the power supply off with an Over Current fault if it ever tries to operate in Current Mode.
- APT** *Adjustable Power Trip*
A third control loop is installed in the power supply, a power loop. This power loop uses an analog multiplier chip to multiply the voltage and current feedback signals to create a power feedback signal. Programming and feedback scaling is 0-10Vdc = 0-100% of rated power. The circuit is configured to trip the power supply off with an Over Power fault if the power loop ever tries to regulate.
- AT*** *Arc Trip*
A control board jumper is moved such that the first arc sensed will shut the power supply off with an ARC fault.
- BPM** *Bipolar Master*
- BPS** *Bipolar Slave*
This option configures two identical but opposite polarity units to function as a single tracking bipolar supply. The voltage feedback of the master (positive unit) is provided to the voltage programming input of the slave (negative unit).
- CMS** *Current Mode Select*
A front panel switch is provided to allow the power supply to either regulate in current mode or create an over current fault when operated in current mode, which will shut down the supply. This is basically a switch selectable AOL option.
- CPC** *Constant Power Control*
Identical to the APT Option with the exception the power supply will run and regulate when the power loop becomes active.
- DPM4** *Digital Panel Meter, 4.5 digits*
The standard 3.5 digit front panel meters are replaced with 4.5 digit panel meters.
- EFR** *External Fault Relay*
A set of relay contacts are provided via the rear panel interface that will change state if the power supply shuts down due to a fault condition.
- eSL** *Ethernet Connectivity/VFD Front Panel*
The eSL Option provides a vacuum fluorescent front panel display, Ethernet connectivity and comprehensive front panel controls.
- FCV** *Fine Control Voltage*
This option adds a second potentiometer to the front panel of the unit. This allows for a finer local adjustment of the output voltage setting.
- FG** *Floating Ground*
All the analog returns inside the power supply are isolated from chassis and brought to one point on the rear panel. Any current that flows out of the power supply via the HV cable/connector on the high side must return back to the multiplier via the load return on the low side. With only one path to flow through on the low side, a current meter can be inserted in series and a safe ground referenced measurement can be made of the actual high voltage output current.
- FGLL** *Floating Ground Low Leakage*
Identical functionality as the FG Option but a shield is placed around the high voltage multiplier to capture any leakage current inside the power supply and return it to the top of the current sense resistor. This negates any internal leakage currents from effecting measurements being made.
- IO*** *Instant On*
A jumper is placed between TB1-15 and TB1-16 on the rear panel, causing the power supply to automatically toggle into HV ON when ever the line voltage is applied.
- LL(X)** *Lead Length*
Extra long high voltage output cable. 20, 40, 60 and 100 feet are standard lengths.
- LR** *Low Ripple*
Done on a case by case basis, the standard unit is evaluated and modifications are done to improve the output ripple to 0.05% peak to peak. The operating frequency might be increased, or additional filtering may be added to the HV multiplier.
- NAD*** *No Arc Detect*
This option removes the arc intervention circuitry from the power supply. Care must be exercised when using this option as damage to the HV multiplier could occur.
- NSS** *No Slow Start*
The standard 6 second long linear ramp of output voltage is removed allowing the high voltage to "step" to its set point when enabled.
- PN** *Positive/Negative*
Reversible polarity option. Units that are not inherently reversible by design (10kV to 130kV) can have their output polarity reversed by the process of exchanging the high voltage multiplier section.
- RFR** *Remote Fault Reset*
This option provides the ability to reset any power supply faults that might occur via toggling a signal on the rear panel interface.
- ROV** *Remote Over Voltage*
The programming signal for the over voltage comparator circuit is made available to the customer remotely, allowing the power supply to be set to trip the OVP circuit anywhere from 0 -110% of rated output voltage.
- SL** *Slides*
Industry standard rack mounted slides are installed on the power supply.
- SS(X)** *Slow Start(X)*
The standard slow start is modified to provide a time of (X) seconds. Time frames of 0.1 seconds to 120 seconds can be accommodated.

There may be some restrictions on multiple option combinations. Please contact our Sales department for more details.

* Option available with the Quick Delivery program



⚠ Not Intended For New Designs

- **1-50kV @ 15-30W**
- **Standard Rack Mounted Design**
- **Low Ripple and Noise**
- **Digital Metering**
- **Reversible Output Polarity**

www.spellmanhv.com/manuals/205B

Spellman's Bertan brand of 205B Series high voltage power supplies provide regulated high voltage outputs from 1 to 50kV. The low noise, linear topology employed results in extremely low output ripple specifications. These 15 to 30W units are inherently reversible by design, providing either positive or negative output polarity. The 205B is fully arc and short circuit protected. Excellent regulation specifications are featured along with outstanding stability performance.

TYPICAL APPLICATIONS

HiPot Testing
CRT Testing
Electrostatics
E Beam Systems
General Laboratory Usage

OPTIONS

RF Isolated (Floating) Output

SPECIFICATIONS

Input Voltage:

115Vac, $\pm 10\%$, 50/60Hz @ 1A
230Vac, $\pm 10\%$, 50/60Hz @ 0.5A
Input voltage is switch selectable

Output Voltage:

See "model selection" table

Output Polarity:

All units are reversible polarity by design

Output Current:

See "model selection" table

Voltage Regulation:

Line: $\leq 50\text{ppm}/0.001\%$ of rated output voltage over specified input voltage range
Load: $\leq 0.005\%$ of rated output voltage for a full load change

Current Regulation:

Internally set to limit at 105% of rated current at full output voltage. Maximum output current at any other voltage setting must be derated linearly down to 30% of maximum at zero output voltage.

Ripple:

See "model selection" table

Temperature Coefficient:

$\leq 50\text{ppm}/^\circ\text{C}$

Stability:

$\leq 0.01\%$ /hour, 0.02% per 8 hours after a 1/2 hour warm up

Accuracy:

Current Monitor: $\pm(0.5\%$ of reading + 0.25% of maximum)
Remote Programming: $\pm(0.1\%$ of setting + 0.1% of maximum)
Voltage Monitor: $\pm(0.1\%$ of reading + 0.1% of maximum)
Front Panel Meter: Voltage $\pm(0.1\%$ of setting + 0.1% of maximum)
Current: $\pm(0.25\%$ of setting + 0.25% of maximum)
Front Panel Control: $\pm(0.25\%$ of setting + 0.05% of maximum)

Operating Temperature:

0°C to +50°C

Storage Temperature:

-40°C to +85°C

Humidity:

20% to 85%RH, non-condensing

Input Line Connector:

IEC320 EMI filter/ input connector, a detachable line cord is provided

Interface Connector:

9 pin "D" connector, a mating connector is provided

Output Connector:

A detachable 10 foot (3 meter) long HV cable is provided

Cooling:

Convection cooled

Dimensions:

1-20kV: 19.0" W X 3.5" H X 9.625" D
(483mm X 89mm X 244mm)
30-50kV: 19.0" W X 5.25" H X 16.0" D
(483mm X 133mm X 406mm)

Weight:

$\leq 20\text{lbs}$ (9.1kg) up to and including 20kV units,
 $\leq 35\text{lbs}$ (15.9kg) for 30kV and 50kV units

Regulatory Approvals:

Compliant to EEC EMC conducted emissions, dip and surge.

Electronic Component (Power Source)

205B series is intended for installation as a component of a system.

It is designed to meet CE standards, with conditions of acceptance often being: customer provided enclosure mounting, EMC filtering, and appropriate protection, and isolation devices. The 205B series is not intended to be operated by end users as a stand-alone device. The 205B series power supply can only be fully assessed when installed within a system, and as a component part within that system.

MODEL SELECTION TABLE

205B Series	Voltage	Current	Ripple
205B-01R	0 to 1kV	0 to 30mA	10mV
205B-03R	0 to 3kV	0 to 10mA	30mV
205B-05R	0 to 5kV	0 to 5mA	50mV
205B-10R	0 to 10kV	0 to 2.5mA	100mV
205B-20R	0 to 20kV	0 to 1mA	300mV
205B-30R	0 to 30kV	0 to 0.5mA	400mV
205B-50R	0 to 50kV	0 to 0.3mA	2V

INTERFACE CONNECTOR

PIN	SIGNAL	PARAMETERS
1	Voltage Monitor	0 to 5Vdc = 0 to 100% rated voltage, Zout = 10KΩ
2	N/C	No Connection
3	Enable	TTL "0" disables HV, TTL "1" or open enables HV
4	+5Vdc Reference	+5.0Vdc @ 10mA, maximum
5	Current Monitor	0 to 5Vdc = 0 to 100% rated current, Zout = 10KΩ
6	Voltage Program Input	0 to 5Vdc = 0 to 100% rated voltage, Zin = 1MΩ
7	Analog Ground	Ground
8	Digital Ground	Ground (for use only with 200-C488, sold separately)
9	Polarity Indicator	Open collector, 30V @ 25mA, positive = ON

OPTIONS:

Isolated (Floating) Output-Option RF

Units can be provided with the output capable of floating up to ±2kV from ground. All controls, programming and monitoring functions are normally referenced to ground. The high voltage output polarity with respect to the floating input terminal is reversible. Floating input connector is Spellman P/N JDK. Mating connector is provided with each unit (Spellman P/N PDB, MHV type UG-932/U). Replace "R" suffix with "RF" for this option.

DIMENSIONS: in.[mm]

FRONT VIEW

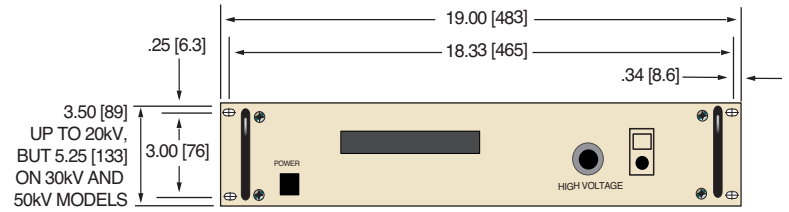

TOP VIEW

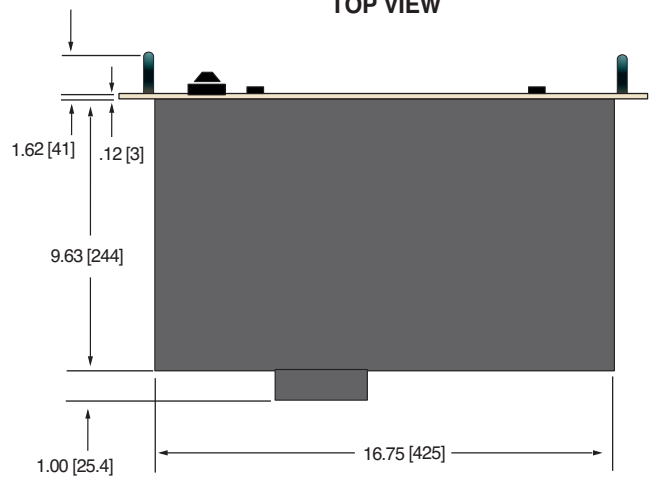

BACK VIEW

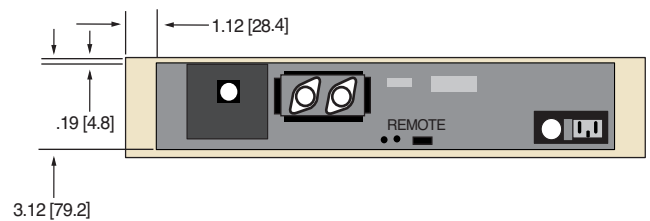



- **Cable Connected 150kV @ 1200W Power Supply**
- **Requires Only 8.75" (5U) Panel Height**
- **Extensive Analog Interface**
- **Arc Quench/Arc Count/Arc Trip**
- **Comprehensive Digital Fault Diagnostics**

www.spellmanhv.com/manuals/SL150KV

Spellman's SL150kV rack mount high voltage power supply is designed for scientific and industrial OEM applications requiring 150kV at 1200 watts in a compact cable connected standard sized rack. Models are available in positive, negative or reversible polarity. The SL150kV is fully arc and short circuit protected. Excellent regulation specifications are provided along with outstanding stability performance. The vacuum encapsulated high voltage output section assures reliable corona free operation by eliminating any concerns due to environmental factors.

TYPICAL APPLICATIONS

Electrostatics
HiPot Testing
Semiconductor Processing
Capacitor Charging

OPTIONS

200	200Vac Input Voltage
AOL	Adjustable Overload Trip
APT	Adjustable Power Trip
AT	Arc Trip
BFP	Blank Front Panel
CPC	Constant Power Control
DPM4	4.5 Digit Panel Meters
EFR	External Fault Relay
LL(X)	Non-Standard HV Cable Length (10 standard)
NAD	No Arc Detect
NSS	No Slow Start
RFR	Remote Fault Reset
SS(X)	Non-Standard Slow Start (6 seconds standard)

SPECIFICATIONS

Front Panel Controls:

Power ON/OFF switch, HV ON Switch, HV OFF Switch with preset feature, 3.5 digit backlight digital meters for display of output voltage and output current, 10 turn locking potentiometers with counting dials for adjustment of both output voltage and output current.

Front Panel Indicators:

HV ON	High Voltage Inhibit
HV OFF	Over Current
Voltage Control Mode	Over Voltage
Current Control Mode	Arc
Interlock Open	Regulation Error
Interlock Closed	Overtemperature

Input:

220Vac $\pm 10\%$, 50/60Hz @ 12A
200Vac $\pm 10\%$, 50/60Hz @ 13.2A

Output Voltage:

0 to 150kV

Output Polarity:

Positive, negative or reversible specify at time of order

Output Current:

8mA

Output Power:

1200W

Voltage Regulation:

Load: 0.01% of rated voltage for a full load change
Line: $\pm 0.01\%$ of rated voltage over specified input voltage range

Current Regulation:

Load: 0.01% of rated current $\pm 100\mu\text{A}$ for full voltage change.
Line: $\pm 0.01\%$ of rated current over specified input voltage range

Ripple:

0.1% peak to peak of maximum output

Temperature Coefficient:

100ppm/ $^{\circ}\text{C}$.

Stability:

100ppm/hr after a 2 hour warm up, for both voltage and current regulation

Operating Temperature:

0 to 40°C operating

Storage Temperature:

-40 to $+85^{\circ}\text{C}$ storage

Humidity:

20% to 85%, non-condensing

Input Line Connector:

3 conductor 12 AWG 6 ft (1.83m) cable, permanently attached

Output Connector:

A detachable 10 ft (3.05m) shielded HV cable is provided

Cooling:

Forced Air

Dimensions:

8.75"H x 19"W x 22"D rack mount.
(22.23cm x 48.26cm x 55.88cm)

Weight:

89 pounds (40.4kg)

Regulatory Approvals:

Designed to meet EEC EMC Directive. Designed to meet to EEC Low Voltage Directive. RoHS Compliant.

Electronic Component (Power Source)

SL150kV series is intended for installation as a component of a system.

It is designed to meet CE standards, with conditions of acceptance often being: customer provided enclosure mounting, EMC filtering, and appropriate protection, and isolation devices. The SL150kV series is not intended to be operated by end users as a stand-alone device. The SL150kV series power supply can only be fully assessed when installed within a system, and as a component part within that system.

SL150KV ANALOG INTERFACE — JB4 25 PIN MALE D CONNECTOR

PIN	SIGNAL	PARAMETERS
1	Power Supply Common	Signal Ground
2	External Inhibit	Ground = Inhibit, Open = HV ON
3	External Interlock	+15Vdc @ open, ≤ 5mA @ closed
4	External Interlock Return	Connect to pin 3 to enable supply
5	Current Monitor	0 to 10Vdc = 0 to 100% rated voltage, Zout = 10kΩ
6	Voltage Monitor	0 to 10Vdc = 0 to 100% rated voltage, Zout = 10kΩ
7	+10Vdc Reference	+10Vdc @ 1mA, maximum
8	Remote Current Program Input	0 to 10Vdc = 0 to 100% rated voltage, Zout = 10kΩ
9	Local Current Program Output	Multi-turn front panel pot for local control capability
10	Remote Voltage Program Input	0 to 10Vdc = 0 to 100% rated voltage, Zout = 10kΩ
11	Local Voltage Program Output	Multi-turn front panel pot for local control capability
12	EFR (Common)	External Fault Relay (Optional)
13	EFR (Normally Open)	External Fault Relay (Optional)
14	Local HV OFF OUT	+15Vdc @ open, <25mA @ closed, connect to HV OFF for front panel operation
15	HV OFF	Connect to HV OFF OUT for front panel operation
16	Remote HV ON	+15Vdc @ 10mA maximum = HV OFF
17	Remote HV OFF Indicator	0 = HV ON, +15Vdc @ 10mA maximum = HV OFF
18	Remote HV ON Indicator	0 = HV OFF, +15Vdc @ 10mA maximum = HV ON
19	Remote Voltage Mode	Open collector 50Vdc @ 10mA maximum, ON = Active
20	Remote Current Mode	Open collector 50Vdc @ 10mA maximum, ON = Active
21	Remote Power Mode	Open collector 50Vdc @ 10mA maximum, ON = Active
22	Power Supply Fault	Open collector, 50Vdc @ 10mA maximum
23	+15Vdc Output	+15Vdc @ 100mA, maximum
24	Power Supply Ground	Signal Ground
25	Shield Return	Chassis Ground

Specify "P" for positive polarity or "N" for negative polarity, and PN = reversible as illustrated below.

Sample Model Number: SL150P1200/BFP/LL(20)

Where SL = power supply series, 150 = maximum output voltage in kV,
P = positive output polarity, 1200 = maximum output power (watts), BFP = Blank Front Panel, LL(20) = 20 foot HV cable.

DIMENSIONS: in.[mm]

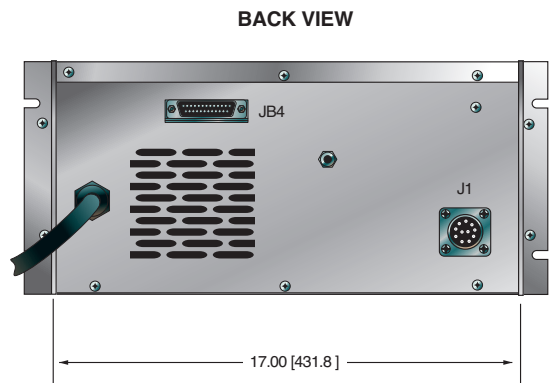
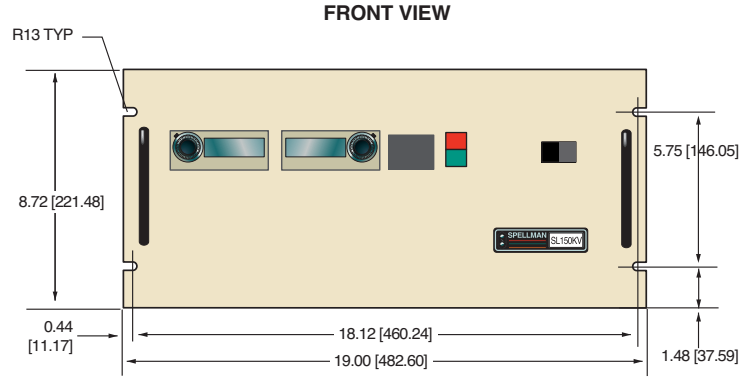



- **Very Compact and Lightweight**
- **Low EMI and RFI**
- **Voltage Range from 500V to 50kV**
- **Reversible Polarity Standard up to 8kV**
- **System Status Indicators**
- **Extensive Analog and Digital Interface**
- **Arc Quench/Arc Count/Arc Trip**
- **OEM Customization Available**

www.spellmanhv.com/manuals/SL2KW

Spellman's SL2KW Series of 2kW high voltage power supplies are designed to meet uncompromising performance standards in a minimum of space. Their circuitry includes a resonant high frequency inverter with proprietary control which provides fault-free operation in extreme transient and arcing environments with greater than 85% efficiency. These full featured supplies are available in a wide range of outputs with many options.

TYPICAL APPLICATIONS

- | | |
|-----------------------------|--------------------|
| Semiconductor Manufacturing | CPT/CRT Testing |
| Electrostatics | Hipot Testing |
| E-Beam Systems | General Laboratory |
| Capacitor Charging | CW Lasers |

OPTIONS

See page 3 for options and descriptions

SPECIFICATIONS

Status Indicators:

Voltage and Current Control Mode, Interlock Open and Closed, High Voltage Inhibit, Overcurrent and Overvoltage, Arc, Regulation Error, Overtemperature.

Input:

Standard: 208Vac \pm 10%, 50/60Hz @ 8.5A/phase, three phase
Optional: 220Vac \pm 10%, 50/60Hz @ 19.75A, single phase

Output:

Models available from 0.5kV to 50kV. Each model is available in positive, negative or reversible polarity output.

Front Panel Controls:

Voltage and current are continuously adjustable by ten-turn potentiometers with lockable counting dials, ON/OFF circuit breaker/lamp, high voltage ON switch/indicator and high voltage OFF switch/indicator.

Voltage Regulation:

Load: 0.005% of maximum voltage +500mV for full load change.
Line: \pm 0.005% of full voltage +500mV over specified input range

Current Regulation:

Load: 0.01% of maximum current \pm 100 μ A for full voltage change.
Line: \pm 0.005% of maximum current for a \pm 10% input line change.

Ripple:

0.1% p-p +1Vrms, three phase line input
0.3% p-p +1Vrms, single phase line input

Temperature Coefficient:

100ppm/ $^{\circ}$ C voltage or current regulated.
Higher stability is available on special order.

Environmental:

Temperature Range:
Operating: 0 $^{\circ}$ C to 50 $^{\circ}$ C.
Storage: -40 $^{\circ}$ C to 85 $^{\circ}$ C.
Humidity:
10 to 90% relative humidity, non-condensing

Stability:

100ppm/hour after 1/2 hour warm-up for both voltage and current regulation.

Metering:

Digital voltage and current meters, 3 $\frac{1}{2}$ digit \pm 1 least significant digit.

Interface Connector:

25 pin male D connector

Output Cable:

10' (3.3m) of shielded high voltage cable removable at the rear panel.

AC Line Input Cable:

A 6 foot (1.83m) cable is permanently attached to the unit. Single phase units use 3 conductor 12AWG cable, three phase units use 4 conductor 16AWG cable.

Dimensions:

3.5" H(2U) x 19" W x 19" D
(8.9cm x 48.3cm x 48.3cm)

Weight:

17 to 26lbs (7.7 to 11.8kg) depending on model.

Regulatory Approvals:

Compliant to EEC EMC Directive for 3 phase units, conducted and radiated emission only for single phase units. Compliant to EEC Low Voltage Directive. RoHS Compliant.

Electronic Component (Power Source)

SL2KW series is intended for installation as a component of a system. It is designed to meet CE standards, with conditions of acceptance often being: customer provided enclosure mounting, EMC filtering, and appropriate protection, and isolation devices. The SL2KW series is not intended to be operated by end users as a stand-alone device. The SL2KW series power supply can only be fully assessed when installed within a system, and as a component part within that system.

SL2KW SELECTION TABLE

MAXIMUM RATING		MODEL NUMBER
kV	mA	
0.5	4000	SL0.5PN2000
1	2000	SL1PN2000
2	1000	SL2PN2000
3	666	SL3PN2000
6	333	SL6PN2000
8	250	SL8PN2000
10	200	SL10*2000
15	133	SL15*2000
20	100	SL20*2000
30	66.6	SL30*2000
40	50	SL40*2000
50	40	SL50*2000

*Specify "P" for positive polarity or "N" for negative polarity or "PN" for reversible polarity

SL2KW 25 PIN D CONNECTOR

PIN	SIGNAL	SIGNAL PARAMETERS
1	Power Supply Common	Signal Ground
2	External Inhibit	Ground=Inhibit, Open=HV On
3	External Interlock	+15V at Open, <15mA at Closed
4	External Interlock Return	Return for Interlock
5	Current Monitor	0 to 10V=0 to 100% Rated Output
6	kV Test Point	0 to 10V=0 to 100% Rated Output
7	+10Vdc Reference	+10Vdc, 1mA Max
8	Remote Current Program In	0 to 10V=0 to 100% Rated Output
9	Local Current Program Out	Front Panel Program Voltage
10	Remote Voltage Program In	0 to 10V=0 to 100% Rated Output
11	Local Voltage Program Out	Front Panel Program Voltage
12	EFR Common	Optional External Fault Relay
13	EFR-NC/EFR-NO	30V @ 2A Maximum
14	Local HV Off Out	+15V at Open, <25mA at Closed
15	HV Off	Connect to HV OFF for FP Operation
16	Remote HV On	+15V, 10mA Max=HV Off
17	Remote HV Off Indicator	0=HV On, +15V, 10mA Max=HV Off
18	Remote HV On Indicator	0=HV Off, +15V, 10mA Max=HV On
19	Remote Voltage Mode	Open Collector 35V Max, 10mA Max, On=Active
20	Remote Current Mode	
21	Remote Power Mode	
22	Remote PS Fault	0=Fault, +15V, 0.1mA Max=No Fault
23	+15V Output	+15V, 100mA Max
24	Power Supply Common	Signal Ground
25	Shield Return	Chassis Ground

How To Order:

Sample model number: SL20PN2000/NSS/DPM4
 SL2KW Series unit, 20kV maximum output voltage, reversible polarity output, 2000 watts, no slow start, 4.5 digit panel meters

There may be some restrictions on multiple option combinations. Please contact our Sales department for more details.

DIMENSIONS: in.[mm]

FRONT VIEW

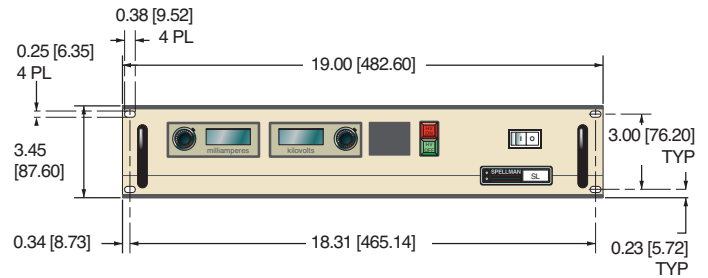

TOP VIEW

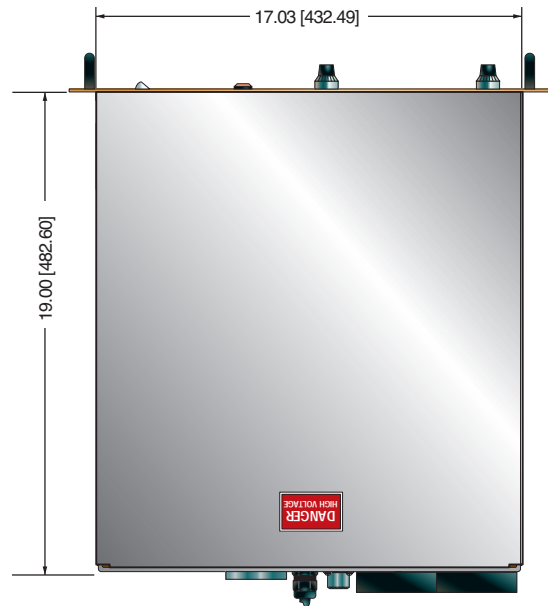

BACK VIEW

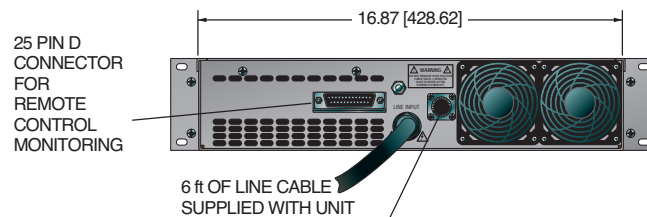

SL2KW SERIES OPTIONS

AOL *Adjustable Overload Trip*

A control board jumper is moved to make the power supply shut down if it ever operates in current mode. This allows the user to set the current programming level as a trip point that will turn the power supply off with an Over Current fault if it ever tries to operate in Current Mode.

APT *Adjustable Power Trip*

A third control loop is installed in the power supply, a power loop. This power loop uses an analog multiplier chip to multiply the voltage and current feedback signals to create a power feedback signal. Programming and feedback scaling is 0-10Vdc = 0-100% of rated power. The circuit is configured to trip the power supply off with an Over Power fault if the power loop ever tries to regulate.

ARC *Arc Sense*

A signal is provided on a spare pin (TB1-21) that changes state whenever the power supply detects an arc.

AT *Arc Trip*

A control board jumper is moved such that the first arc sensed will shut the power supply off with an ARC fault.

BPM *Bipolar Master***BPS** *Bipolar Slave*

This option configures two identical but opposite polarity units to function as a single tracking bipolar supply. The voltage feedback of the master (positive unit) is provided to the voltage programming input of the slave (negative unit).

CMS *Current Mode Select*

A front panel switch is provided to allow the power supply to either regulate in current mode or create an over current fault when operated in current mode, which will shut down the supply. This is basically a switch selectable AOL option.

CPC *Constant Power Control*

Identical to the APT Option with the exception the power supply will run and regulate when the power loop becomes active.

DPM4 *Digital Panel Meter, 4.5 digits*

The standard 3.5 digit front panel meters are replaced with 4.5 digit panel meters.

EFR *External Fault Relay*

A set of relay contacts are provided via the rear panel interface that will change state if the power supply shuts down due to a fault condition.

FCV *Fine Control Voltage*

This option adds a second potentiometer to the front panel of the unit. This allows for a finer local adjustment of the output voltage setting.

IO *Instant On*

A jumper is placed between TB1-15 and TB1-16 on the rear panel, causing the power supply to automatically toggle into HV ON when ever the line voltage is applied.

LL(X) *Lead Length*

Extra long high voltage output cable. 20, 40, 60 and 100 feet are standard lengths. Non standard lengths can be custom ordered.

NAD *No Arc Detect*

This option removes the arc intervention circuitry from the power supply. Care must be exercised when using this option as damage to the HV multiplier could occur.

NSS *No Slow Start*

The standard 6 second long linear ramp of output voltage is removed allowing the high voltage to "step" to its set point when enabled.

PN *Positive/Negative*

Reversible polarity option. Units that are not inherently reversible by design (10kV to 50kV) can have their output polarity reversed by the process of exchanging the high voltage multiplier section.

RFR *Remote Fault Reset*

This option provides the ability to reset any power supply faults that might occur via toggling a signal on the rear panel interface.

ROV *Remote Over Voltage*

The programming signal for the over voltage comparator circuit is made available to the customer remotely, allowing the power supply to be set to trip the OVP circuit anywhere from 0 -110% of rated output voltage.

SL *Slides*

Industry standard rack mounted slides are installed on the power supply.

SS(X) *Slow Start(X)*

The standard slow start is modified to provide a time of (X) seconds. Time frames of 0.1 seconds to 120 seconds can be accommodated.

There may be some restrictions on multiple option combinations. Please contact our Sales department for more details.



- **160kV - 360kV Outputs**
- **Low Ripple**
- **High Stability**
- **Overcurrent, Overvoltage and Arc Protection**
- **Arc Detect**
- **Lightweight, Compact Size**
- **OEM Customization Available**

www.spellmanhv.com/manuals/SLS

The SLS series of high voltage power supplies provide up to 2000 watts of power with voltage outputs ranging from 160kV to 360kV. These power supplies utilize high frequency resonant inverters with proprietary controls for reliable operation in extreme environments. The high voltage multiplier unit is built with a hybrid design of solid encapsulation and air, thus reducing its overall size. Comprised of 20kV interlocking wafers, the multiplier unit offers flexible building blocks for many different output configurations.

TYPICAL APPLICATIONS

Ion Implantation
Particle Accelerators
Electron Guns

SPECIFICATIONS

Input Voltage:

Standard: 220Vac \pm 10%, 50/60Hz @ 8A/phase, three phase
Optional: 200Vac \pm 10%, 50/60Hz @ 8.9A/phase, three phase

Output Voltage Range:

Models available from 160kV to 360kV and up to 2000W. Each model is available with positive or negative polarity outputs.

Voltage Regulation:

Better than 0.05% for specified line variations and load variations.

Ripple:

0.1% p-p of maximum output voltage.

Remote Voltage Control:

0 to +10V for 0 to maximum voltage. Accuracy and repeatability: 1% of maximum rating.

Remote Current Control:

0 to +10V for 0 to maximum voltage. Accuracy and repeatability: 1% of maximum rating.

Voltage Monitor:

0 to 10V equivalent to rated voltage. Accuracy, 1% reading.

Current Monitor:

0 to 10V equivalent to rated current. Accuracy, 1% reading.

Stability:

0.05% per hour after 1/2 hour warm-up.
0.05% per 8 hours.

Slow Start:

Slow start times: 6 seconds standard.

Temperature Coefficient:

0.01% per degrees C.

Protection:

Overcurrent, Overvoltage, Arc protection, Overtemperature.

Arc Detect:

If 8 arcs occur in a 10 second, non-synchronous time window, the supply reverts to the Power Down Mode with an ARC fault displayed on the front panel default diagnostic display.

Environmental:

Temperature Range:
Operating: 0°C to 40°C
Storage: -20°C to 85°C

Humidity:

10% to 70%, non-condensing.

Dimensions:

Inverter Driver Chassis:
3.50" (2U) H x 19.0" W x 19.0" D
(8.9cm x 48.3cm x 48.3cm)

Multiplier Unit:

See page 3.

Distance from Stack to Driver:

2.5 meters \pm 0.1 meter maximum.

Signal Connector:

25 pin, male D connector, J3.

Metering:

Front panel, 3.5 digit, digital voltage and current meters.

Front Panel Controls:

Voltage and current are continuously adjustable by ten-turn potentiometers with lockable counting dials, ON/OFF circuit breaker/lamp, high voltage ON switch/indicator and high voltage OFF switch/indicator.

Front Panel Status Indicators:

Voltage Control Mode	Overtemperature
Current Control Mode	Overpower (optional)
Interlock Open	Overcurrent
Interlock Closed	Overvoltage
High Voltage Inhibit	Arc
Regulation Error	

Regulatory Approvals:

RoHS compliant.

Electronic Component (Power Source)

SLS series is intended for installation as a component of a system.

It is designed to meet CE standards, with conditions of acceptance often being: customer provided enclosure mounting, EMC filtering, and appropriate protection, and isolation devices. The SLS series is not intended to be operated by end users as a stand-alone device. The SLS series power supply can only be fully assessed when installed within a system, and as a component part within that system.

Corona Dome Terminations:

The SLS Series of "stack" configured high voltage power supplies come in a various output voltages and different physical configurations. Appropriate corona relief is required for these units to operate at maximum output voltage. Frequently users will provide the corona relief needed so Spellman will provide stack assemblies that by themselves will not be able to operate at maximum output voltage corona free. Please be certain to discuss your requirements with Spellman to be assured you get a stack assembly in the physical configuration you require for your application. The optional K941 Toroid (5" x 20") should be considered if customer corona relief will not be provided.



360kV Stack
shown with
optional
K941 Toroid

SLS SELECTION TABLE

MAXIMUM RATING		MODEL NUMBER
kV	mA	
160	12.5	SLS160*2000
200	10.0	SLS200*2000
260	7.7	SLS260*2000
300	6.6	SLS300*2000
360	5.5	SLS360*2000

*Specify "P" for positive polarity or "N" for negative polarity
Other combinations of voltage and current are available.

SLS I/O INTERFACE CONNECTOR 25 PIN

PIN	SIGNAL
1	Power Supply Common
2	External Inhibit
3	External Interlock
4	External Interlock Return
5	Current Monitor
6	Voltage Monitor
7	+10V Reference
8	Remote Current Program In
9	Local Current Program Out
10	Remote Voltage Program In
11	Local Voltage Program Out
12	Optional EFR (common)
13	Optional EFR (normally closed)
14	Local HV OFF Out
15	HV OFF
16	Remote HV ON
17	Remote HV OFF Indicator
18	Remote HV ON Indicator
19	Remote Voltage Mode
20	Remote Current Mode
21	Spare
22	Remote PS Fault
23	+15V Output
24	Power Supply Common
25	Shield Return

DIMENSIONS: in.[mm]

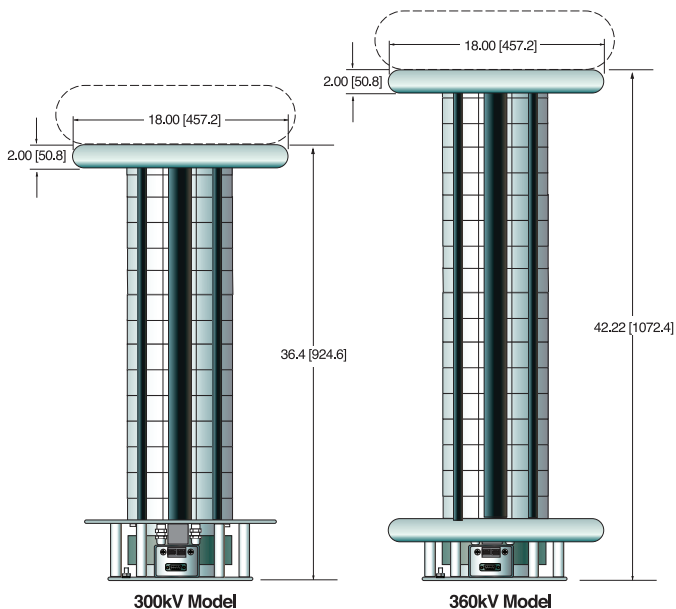
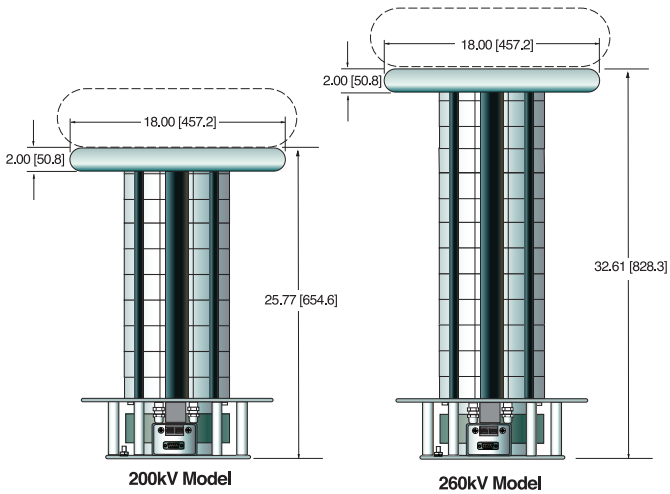
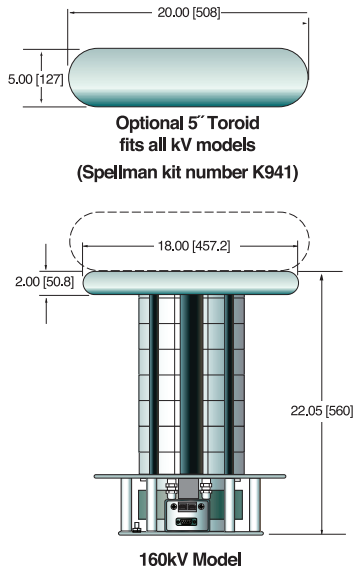

FRONT VIEW

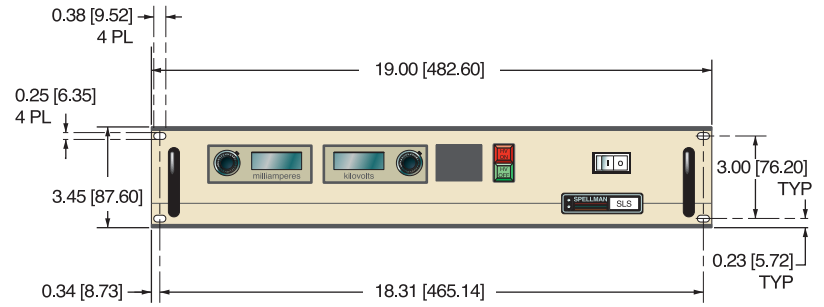

TOP VIEW

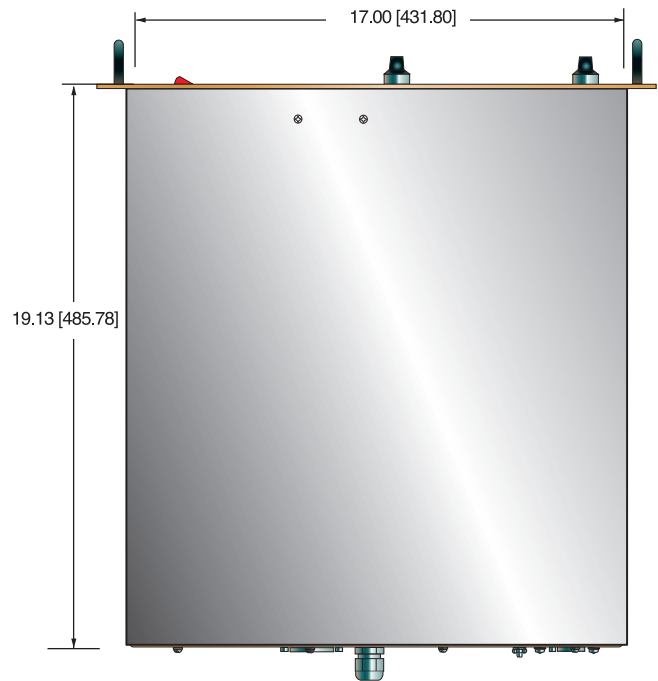

BACK VIEW

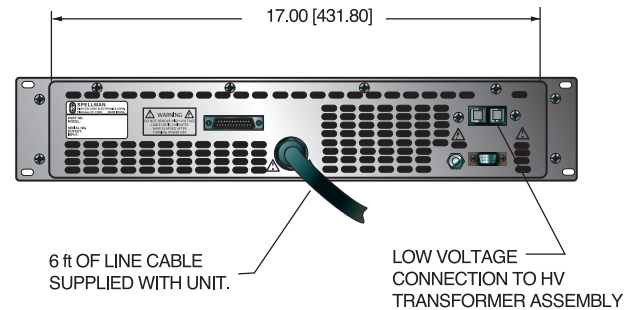



- **4kW's in Single 3U (5.25") Chassis**
- **Models from 1kV to 70kV**
- **Remote Analog and Remote Ethernet Interface**
- **Arc and Short Circuit Protected**
- **Customer Configurable Features Via Ethernet Interface**
- **OEM Customization Available**

www.spellmanhv.com/manuals/STA

Spellman's STA Series of 4kW high voltage power supplies are available in positive or negative polarities in 15 different models with outputs ranging from 1kV to 70kV. A full featured front panel allows easy local control, while an extensive analog interface provides comprehensive remote capability. The standard Ethernet and RS-232 digital interfaces simplify integrating the STA into your system design.

The STA's robust IGBT inverter is inherently fault tolerant and is ideal for demanding applications like semiconductor processing and vacuum deposition. Many operational features can be configured by the user to suit their particular requirements.

TYPICAL APPLICATIONS

- Ion Beam Implantation
- Semiconductor Processing
- Electron Beam Welding
- Capacitor Charging
- High Power RF Transmitters
- Electrostatic Precipitators
- X-Ray Systems

HARDWARE BASED OPTIONS

- BFP** Blank Front Panel
- HS** High Stability
- LL(X)** High Voltage Cable Length
- 1PH** 180-264Vac, Single Phase Input

SOFTWARE CONFIGURABLE FEATURES

- Adjustable Overload Trip
- Arc Trip Count
- Arc Quench Time
- Arc Re-Ramp Time
- Constant Power Control
- Adjustable Power Trip
- Slow Start Ramp Times

SPECIFICATIONS

Input Voltage:

- Standard: 180-264Vac, 50/60Hz, three phase, 90% efficiency, 0.85 power factor
- Optional: 180-264Vac 50/60Hz, single phase (1PH)

Input Current:

- Standard: 180-264Vac, three phase 17 amps, maximum
- Optional: 180-264Vac, single phase 38 amps, maximum

Output Voltage:

15 models from 1kV to 70kV. Each model is available with positive or negative outputs.

Local Output Controls:

Voltage and current are continuously adjustable over entire range via ten-turn potentiometers with lockable counting dials.

Voltage Regulation:

- Load: 0.05% of full voltage +500mV for full load change.
- Line: 0.05% of full voltage +500mV over specified input range.

Current Regulation:

- Load: 0.05% of full current $\pm 100\mu\text{A}$ for any voltage change.
- Line: 0.05% of full current over specified input range.

Ripple:

0.1% p-p +1Vrms

Stability:

0.02%hr. after 1 hour warm-up.

Temperature Coefficient:

100ppm/°C. Higher stability (50ppm/°C) available on special order via the HS option

Environmental:

- Temperature Range:
 - Operating: 0°C to 40°C
 - Storage: -40°C to 85°C
- Humidity:
 - 10% to 90% RH, non-condensing.

Cooling:

Forced air; inlet through side panels, outlet at rear panel

Metering:

Digital voltage and current meters, accurate to within 1%

System Status Display:

"Dead Front" type indicators provide status of up to 12 system operations including voltage and current regulation, fault conditions and circuit control.

Analog Interface Connector:

50 pin female D connector

High Voltage Output Cable:

A detachable 10' (3.05m) long shielded HV cable is provided

Dimensions:

1kV to 70kV:
5.25" (3U)H X 19" W X 21" D (133mm x 482mm x 533mm)

Weight:

1kV to 8kV: 46 lbs. (20.87kg)
10kV to 70kV: 58 lbs. (26.31kg)
Individual kV models may vary

Regulatory Approvals:

Designed to meet EEC EMC Directive. Compliant to EEC Low Voltage Directive. RoHS Compliant.

Electronic Component (Power Source)

STA series is intended for installation as a component of a system.

It is designed to meet CE standards, with conditions of acceptance often being: customer provided enclosure mounting, EMC filtering, and appropriate protection, and isolation devices. The STA series is not intended to be operated by end users as a stand-alone device. The STA series power supply can only be fully assessed when installed within a system, and as a component part within that system.

Digital Interface

The STA features a standard RS-232 and Ethernet digital interface. Utilizing these standard digital interfaces can dramatically simplify power supply interfacing requirements saving the user both time and money, while enhancing functionality and overall capability. Spellman provides a GUI with the STA that allows the customer to both customize operational features of the STA while also providing basic power supply operational features. Details of the STA's digital interface capability are described in the STA manual, downloadable via the link on the first page of this data sheet.

Arc Intervention

Spellman's STA power supplies have an arc intervention feature that senses arc currents via a fast acting current sense transformer. The purpose of the arc intervention circuitry is to prevent power supply damage from continuous, long term arcing. The factory default configuration will trip off the unit with an Arc Fault if 4 arcs occur in a 10 second time period. Customers can change basic arc intervention parameters (Arc Count, Arc Quench, Reramp Time, and Window Time) within preset limits via the digital interface interface; customized units can be provided for unique arc prone environments, contact Spellman for details.

STA SELECTION TABLE

MAXIMUM RATING		MODEL NUMBER
kV	mA	
1	4,000	STA1*4
2	2,000	STA2*4
3	1,333	STA3*4
4	1,000	STA4*4
6	667	STA6*4
8	500	STA8*4
10	400	STA10*4
12	333	STA12*4
15	267	STA15*4
20	200	STA20*4
30	133	STA30*4
40	100	STA40*4
50	80	STA50*4
60	67	STA60*4
70	57	STA70*4

*Substitute "P" for positive polarity and "N" for negative polarity. Polarity must be specified at time of order.



STA rear panel shown with local operation plug installed in 50 pin D connector

JB1 STA ANALOG INTERFACE — 50 PIN FEMALE D CONNECTOR

PIN	SIGNAL	PARAMETERS
1	Power Supply Common	Power Supply Ground
2	Reset/HV Inhibit	Normally open, Low = Reset/Inhibit
3	External Interlock	+24Vdc @ open, <25mA @ closed
4	External Interlock Return	Return for External Interlock
5	mA Test Point	0-10Vdc = 0-100% rated output, Zout= 1KΩ, 1%
6	kV Test Point	0-10Vdc = 0-100% rated output, Zout= 1KΩ, 1%
7	+10Vdc Reference Output	+10Vdc @ 1mA
8	mA Program Input	0-10Vdc = 0-100% rated output, Zin>10MΩ
9	Local mA Program Output	0-10Vdc = 0-100% rated output, front panel pot
10	kV Program Input	0-10Vdc = 0-100% rated output, Zin>10MΩ
11	Local kV Program Output	0-10Vdc = 0-100% rated output, front panel pot
12	Remote Power On Output	+24Vdc @ open, 2A peak, 1Adc @ closed
13	Remote Power On Return	Return for Remote Power On
14	Remote HV Off	+24Vdc @ open, 2A peak, 1Adc @ closed, connect to pin15 for front panel operation
15	Remote HV Off/On Common	HV On/Off Common
16	Remote HV On	+24Vdc @ open, 2A peak, 1Adc @ closed, momentarily connect to pin 15 enable high voltage
17	HV Off Indicator	+24Vdc @ 25mA = HV Off
18	HV On Indicator	+24Vdc @ 25mA = HV On
19	Power Supply Common	Supply Ground
20	+24Vdc Output	+24Vdc @ 100mA, maximum
21	Voltage Mode Status	Open Collector, Low = Active
22	Current Mode Status	Open Collector, Low = Active
23	Power Mode Status	Open Collector, Low = Active
24	Interlock Closed Status	Open Collector, Low = Active
25	Power Test Point	0-10Vdc = 0-100% rated output, Zout= 5KΩ, 1%
26	Spare	
27	Spare	
28	Remote Overvoltage Adjust	0-10Vdc = 0-100% rated output
29	Over Power Fault	Open Collector, Low = Active
30	Over Voltage Fault	Open Collector, Low = Active
31	Over Current Fault	Open Collector, Low = Active
32	System Fault	Open Collector, Low = Active
33	RGLT Error Fault	Open Collector, Low = Active
34	Arc	Open Collector, Low = Active
35	Over Temp Fault	Open Collector, Low = Active
36	AC Fault	Open Collector, Low = Active
37	Spare	
38	Spare	
39	Spare	
40	Spare	
41	Spare	
42	Remote Power Program Input	0-10Vdc = 0-100% rated output, Zin>10MΩ
43	Local Power Program Output	0-10Vdc = 0-100% rated output, internal pot
44	+5Vdc Output	+5Vdc @ 100mA, maximum
45	+15Vdc Output	+15Vdc @ 100mA, maximum
46	-15Vdc Output	-15Vdc @ 10mA, maximum
47	RS232 Tx	
48	RS232 Rx	
49	RS232 GND	
50	Power Supply Common	Power Supply Ground

DIMENSIONS: in.[mm]

FRONT VIEW

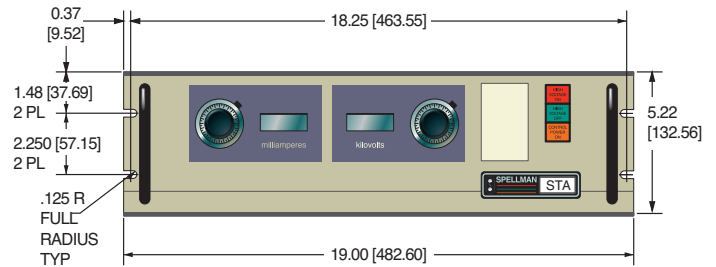

TOP VIEW

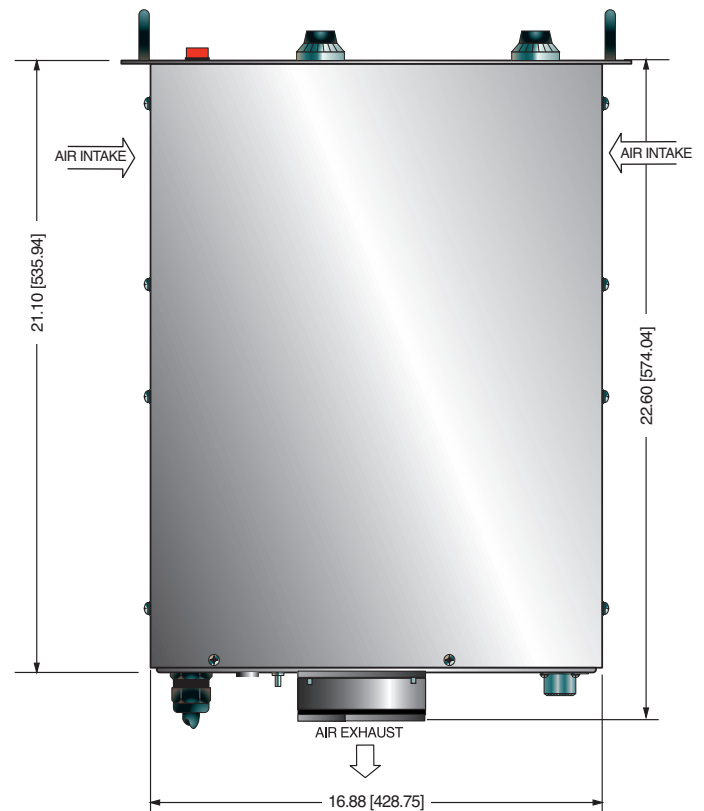

BACK VIEW

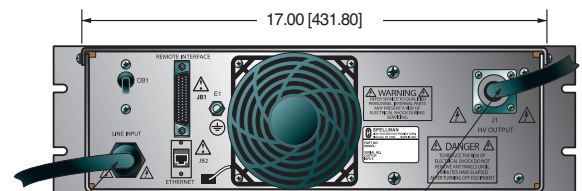

6 ft OF LINE CABLE SUPPLIED WITH UNIT.

MATING CONNECTOR AND 10ft OF HIGH VOLTAGE CABLE SUPPLIED WITH UNIT.





- **6kW's in Single 6U (10.5") Chassis**
- **Models from 1kV to 150kV**
- **Remote Analog and Remote Ethernet Interface**
- **Arc and Short Circuit Protected**
- **Customer Configurable Features Via Ethernet Interface**
- **OEM Customization Available**

Need higher power? The ST Series provides 12kW in the same size as the STR Series

www.spellmanhv.com/manuals/STR

Spellman's STR Series of 6kW high voltage power supplies are available in positive or negative polarities in 19 different models with outputs ranging from 1kV to 150kV. A full featured front panel allows easy local control, while an extensive analog interface provides comprehensive remote capability. The standard Ethernet and RS-232 digital interfaces simplify integrating the STR into your system design.

The STR's robust IGBT inverter is inherently fault tolerant and is ideal for demanding applications like semiconductor processing and vacuum deposition. Many operational features can be configured by the user to suit their particular requirements.

TYPICAL APPLICATIONS

- Ion Beam Implantation
- Semiconductor Processing
- Electron Beam Welding
- Capacitor Charging
- High Power RF Transmitters
- Electrostatic Precipitators
- X-Ray Systems

HARDWARE BASED OPTIONS

- BFP** Blank Front Panel
- HS** High Stability
- LL(X)** High Voltage Cable Length
- 400VAC** 360-528Vac, Three Phase Input
- 1PH** 180-264Vac, Single Phase Input

SOFTWARE CONFIGURABLE FEATURES

- Adjustable Overload Trip
- Arc Trip Count
- Arc Quench Time
- Arc Re-Ramp Time
- Constant Power Control
- Adjustable Power Trip
- Slow Start Ramp Times

SPECIFICATIONS

Input Voltage:

Standard: 180-264Vac, 50/60Hz, three phase, 90% efficiency, 0.85 power factor
Optional: 360-528Vac 50/60Hz, three phase (400VAC)
180-264Vac 50/60Hz, single phase (1PH)

Input Current:

Standard: 180-264Vac, three phase 25 amps, maximum
Optional: 360-528Vac, three phase 12.5 amps, maximum
180-264Vac, single phase 57 amps, maximum

Output Voltage:

19 models from 1kV to 150kV. Each model is available with positive or negative outputs. 1kV to 10kV units are internally reversible.

Local Output Controls:

Voltage and current are continuously adjustable over entire range via ten-turn potentiometers with lockable counting dials.

Voltage Regulation:

Load: 0.05% of full voltage +500mV for full load change.
Line: 0.05% of full voltage +500mV over specified input range.

Current Regulation:

Load: 0.05% of full current $\pm 100\mu\text{A}$ for any voltage change.
Line: 0.05% of full current over specified input range.

Ripple:

0.1% p-p +1Vrms

Stability:

0.02%/hr. after 1 hour warm-up.

Temperature Coefficient:

100ppm/°C. Higher stability (50ppm/°C) available on special order via the HS option

Environmental:

Temperature Range:
Operating: 0°C to 40°C
Storage: -40°C to 85°C
Humidity:
10% to 90% RH, non-condensing.

Cooling:

Forced air; inlet through side panels, outlet at rear panel

Metering:

Digital voltage and current meters, accurate to within 1%

System Status Display:

"Dead Front" type indicators provide status of up to 12 system operations including voltage and current regulation, fault conditions and circuit control.

Analog Interface Connector:

50 pin female D connector

High Voltage Output Cable:

A detachable 10' (3.05m) long shielded HV cable is provided

Dimensions:

1kV to 120kV:
10.5" (6U)H X 19" W X 21" D (266mm x 482mm x 533mm)
150kV:
10.5" (6U)H X 19" W X 23" D (266mm x 482mm x 584mm)

Weight:

1kV to 50kV: <100 pounds (45.36kg)
60kV to 120kV: <140 pounds (63.50kg)
150kV: <150 pounds (68kg)
Individual kV models may vary

Regulatory Approvals:

Compliant to EEC EMC Directive. Compliant to EEC Low Voltage Directive. RoHS Compliant.

Electronic Component (Power Source)

STR series is intended for installation as a component of a system.

It is designed to meet CE standards, with conditions of acceptance often being: customer provided enclosure mounting, EMC filtering, and appropriate protection, and isolation devices. The STR series is not intended to be operated by end users as a stand-alone device. The STR series power supply can only be fully assessed when installed within a system, and as a component part within that system.

STR SELECTION TABLE

MAXIMUM RATING		MODEL NUMBER
kV	mA	
1	6,000	STR1*6
2	3,000	STR2*6
3	2,000	STR3*6
4	1,500	STR4*6
6	1,000	STR6*6
8	750	STR8*6
10	600	STR10*6
12	500	STR12*6
15	400	STR15*6
20	300	STR20*6
30	200	STR30*6
40	150	STR40*6
50	120	STR50*6
60	100	STR60*6
70	86	STR70*6
80	75	STR80*6
100	60	STR100*6
120	50	STR120*6
150	40	STR150*6

*Substitute "P" for positive polarity and "N" for negative polarity. Polarity must be specified at time of order.

1-10kV units are inherently reversible by design requiring an internal wiring change to swap polarities. Intermediate voltage units are available by special order.

Digital Interface

The STR features a standard RS-232 and Ethernet digital interface. Utilizing these standard digital interfaces can dramatically simplify power supply interfacing requirements saving the user both time and money, while enhancing functionality and overall capability. Spellman provides a GUI with the STR that allows the customer to both customize operational features of the STR while also providing basic power supply operational features. Details of the STR's digital interface capability are described in the STR manual, downloadable via the link on the first page of this data sheet.

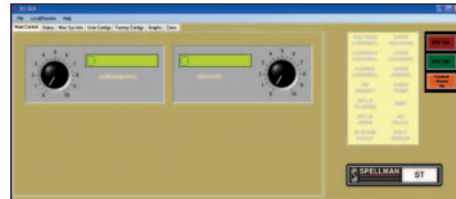

Main control screen



Status screen



User configuration screen

Arc Intervention

Spellman's STR power supplies have an arc intervention feature that senses arc currents via a fast acting current sense transformer. The purpose of the arc intervention circuitry is to prevent power supply damage from continuous, long term arcing. The factory default configuration will trip off the unit with an Arc Fault if 4 arcs occur in a 10 second time period. Customers can change basic arc intervention parameters (Arc Count, Arc Quench, Reramp Time, and Window Time) within preset limits via the digital interface interface; customized units can be provided for unique arc prone environments, contact Spellman for details.



STR rear panel view

JB1 STR ANALOG INTERFACE— 50 PIN FEMALE D CONNECTOR

PIN	SIGNAL	PARAMETERS
1	Power Supply Common	Power Supply Ground
2	Reset/HV Inhibit	Normally open, Low = Reset/Inhibit
3	External Interlock	+24Vdc @ open, <25mA @ closed
4	External Interlock Return	Return for External Interlock
5	mA Test Point	0-10Vdc = 0-100% rated output, Zout= 1KΩ, 1%
6	kV Test Point	0-10Vdc = 0-100% rated output, Zout= 1KΩ, 1%
7	+10Vdc Reference Output	+10Vdc @ 1mA
8	mA Program Input	0-10Vdc = 0-100% rated output, Zin>10MΩ
9	Local mA Program Output	0-10Vdc = 0-100% rated output, front panel pot
10	kV Program Input	0-10Vdc = 0-100% rated output, Zin>10MΩ
11	Local kV Program Output	0-10Vdc = 0-100% rated output, front panel pot
12	Remote Power On Output	+24Vdc @ open, 2A peak, 1Adc @ closed
13	Remote Power On Return	Return for Remote Power On
14	Remote HV Off	+24Vdc @ open, 2A peak, 1Adc @ closed, connect to pin15 for front panel operation
15	Remote HV Off/On Common	HV On/Off Common
16	Remote HV On	+24Vdc @ open, 2A peak, 1Adc @ closed, momentarily connect to pin 15 enable high voltage
17	HV Off Indicator	+24Vdc @ 25mA = HV Off
18	HV On Indicator	+24Vdc @ 25mA = HV On
19	Power Supply Common	Supply Ground
20	+24Vdc Output	+24Vdc @ 100mA, maximum
21	Voltage Mode Status	Open Collector, Low = Active
22	Current Mode Status	Open Collector, Low = Active
23	Power Mode Status	Open Collector, Low = Active
24	Interlock Closed Status	Open Collector, Low = Active
25	Power Test Point	0-10Vdc = 0-100% rated output, Zout= 5KΩ, 1%
26	Spare	
27	Spare	
28	Remote Overvoltage Adjust	0-10Vdc = 0-100% rated output
29	Over Power Fault	Open Collector, Low = Active
30	Over Voltage Fault	Open Collector, Low = Active
31	Over Current Fault	Open Collector, Low = Active
32	System Fault	Open Collector, Low = Active
33	RGLT Error Fault	Open Collector, Low = Active
34	Arc	Open Collector, Low = Active
35	Over Temp Fault	Open Collector, Low = Active
36	AC Fault	Open Collector, Low = Active
37	Spare	
38	Spare	
39	Spare	
40	Spare	
41	Spare	
42	Remote Power Program Input	0-10Vdc = 0-100% rated output, Zin>10MΩ
43	Local Power Program Output	0-10Vdc = 0-100% rated output, internal pot
44	+5Vdc Output	+5Vdc @ 100mA, maximum
45	+15Vdc Output	+15Vdc @ 100mA, maximum
46	-15Vdc Output	-15Vdc @ 10mA, maximum
47	RS232 Tx	
48	RS232 Rx	
49	RS232 GND	
50	Power Supply Common	Power Supply Ground

DIMENSIONS: in.[mm]

FRONT VIEW

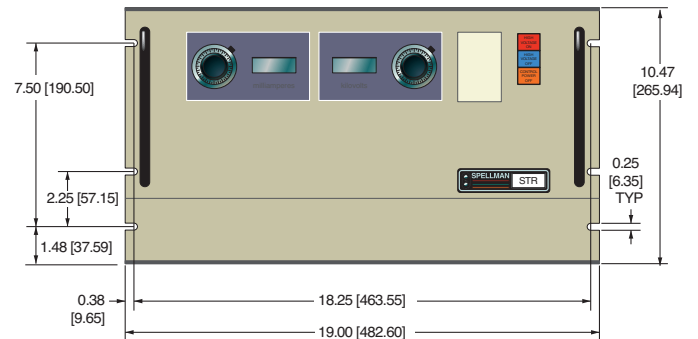

TOP VIEW

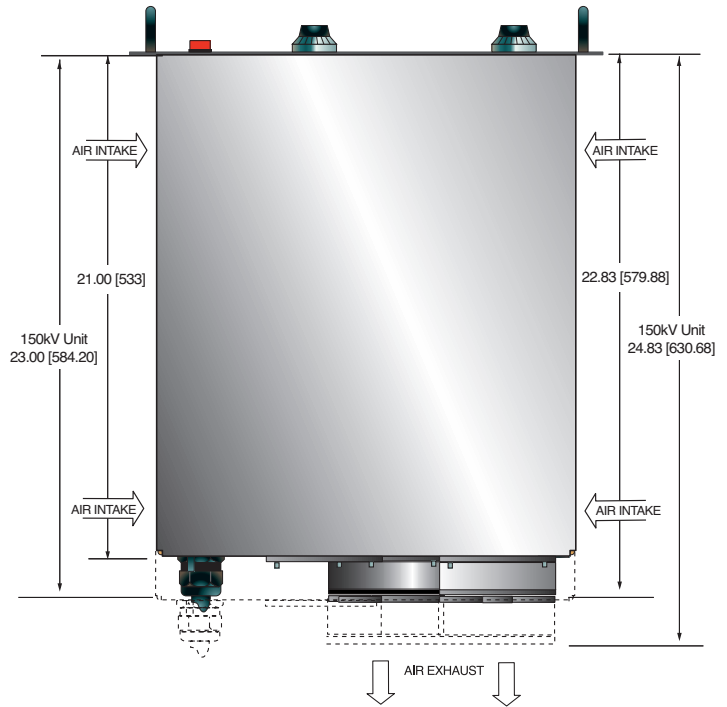

BACK VIEW

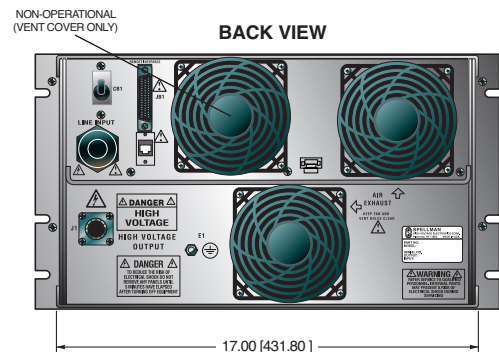



1-150kV



225kV

- **12kW's in Single 6U (10.5") Chassis**
- **Models from 1kV to 225kV**
- **Remote Analog and Remote Ethernet Interface**
- **Parallel Units for >100kW's**
- **Arc and Short Circuit Protected**
- **Customer Configurable Features Via Ethernet Interface**
- **OEM Customization Available**

www.spellmanhv.com/manuals/ST

SPECIFICATIONS

Input Voltage:

- Standard: 180-264Vac, 50/60Hz, three phase, 90% efficiency, 0.85 power factor
Optional: 360-528Vac 50/60Hz, three phase (400Vac)

Input Current:

- Standard: 180-264Vac, three phase; 50 amps, maximum
Optional: 360-528Vac, three phase; 25 amps, maximum

Output Voltage:

20 models from 1kV to 225kV. Each model is available with positive or negative outputs. 1kV to 10kV units are internally reversible.

Local Output Controls:

Voltage and current are continuously adjustable over entire range via ten-turn potentiometers with lockable counting dials.

Voltage Regulation:

- Load: 0.05% of full voltage +500mV for full load change.
Line: 0.05% of full voltage +500mV over specified input range.

Current Regulation:

- Load: 0.05% of full current $\pm 100\mu\text{A}$ for any voltage change.
Line: 0.05% of full current over specified input range.

Ripple:

0.3% p-p +1Vrms. Lower ripple available via special order

Stability:

0.02%hr. after 1 hour warm-up.

Temperature Coefficient:

100ppm/°C. Higher stability (50ppm/°C) available on special order via the HS option

Environmental:

Temperature Range:
Operating: 0°C to 40°C
Storage: -40°C to 85°C
Humidity:
10% to 90% RH, non-condensing.

Cooling:

Forced air; inlet through side panels, outlet at rear panel

Metering:

Digital voltage and current meters, accurate to within 1%

System Status Display:

"Dead Front" type indicators provide status of up to 12 system operations including voltage and current regulation, fault conditions and circuit control.

Input Line Connector:

A 6 foot (1.8 meter) long captive line cord is provided.

Spellman's ST Series of 12kW high voltage power supplies are available in positive or negative polarities in 20 different models with outputs ranging from 1kV to 225kV. A full featured front panel allows easy local control, while an extensive analog interface provides comprehensive remote capability. The standard Ethernet and RS-232 digital interfaces simplify integrating the ST into your system design.

The ST's robust IGBT inverter is inherently fault tolerant and is ideal for demanding applications like semiconductor processing and vacuum deposition. Many operational features can be configured by the user to suit their particular requirements. Power >100kW's can be provided by configuring additional chassis in parallel.

TYPICAL APPLICATIONS

Ion Beam Implantation
Semiconductor Processing
Electron Beam Welding
Capacitor Charging
High Power RF Transmitters
Electrostatic Precipitators
X-Ray Systems

HARDWARE BASED OPTIONS

BFP Blank Front Panel
HS High Stability
LL(X) High Voltage Cable Length
400VAC 360-528Vac Input

SOFTWARE CONFIGURABLE FEATURES

Adjustable Overload Trip
Arc Trip Count
Arc Quench Time
Arc Re-Ramp Time
Constant Power Control
Adjustable Power Trip
Slow Start Ramp Times

Analog Interface Connector:

50 pin female D connector

High Voltage Output Cable:

1-150kV: A detachable 10' (3.05m) long shielded HV cable is provided

225kV: R-28 type X-Ray connector. No output cable is provided

Dimensions:

1kV to 120kV:
10.5" (6U)H X 19" W X 21" D (266mm x 482mm x 533mm)
150kV:
10.5" (6U)H X 19" W X 23" D (266mm x 482mm x 584mm)
225kV:
20.55" H X 17.01" W X 29.7" D (521mm x 432mm x 754mm)

Weight:

1kV to 50kV: <100 pounds (45.36kg)
60kV to 120kV: <140 pounds (63.50kg)
150kV: <150 pounds (68.03kg)
225kV: <260 pounds (117.9kg)
Individual kV models may vary

Regulatory Approvals:

Compliant to EEC EMC Directive. Compliant to EEC Low Voltage Directive. RoHS Compliant.

Electronic Component (Power Source)

ST series is intended for installation as a component of a system.

It is designed to meet CE standards, with conditions of acceptance often being: customer provided enclosure mounting, EMC filtering, and appropriate protection, and isolation devices. The ST series is not intended to be operated by end users as a stand-alone device. The ST series power supply can only be fully assessed when installed within a system, and as a component part within that system.

Parallel Capability

The ST series is designed to offer additional power capability by adding chassis in parallel to create a Master/Slave configuration providing up to and beyond 100kW's. The Master chassis is the point of connection for customer interfacing; this multi-chassis system effectively functions as a single power supply. The Master unit retains the full featured front panel, while slave units have a Blank Front Panel. To configure an orderable model number, simply use Spellman's applicable base ST model number and increment the power denominator in 12kW steps as required:

ST60P24 This would be an ST with a 60kV, positive polarity, providing 24kW's of power (2 chassis)



Rear panel showing connections for parallel operation



Master/slave 24kW ST

Digital Interface

The ST features a standard RS-232 and Ethernet digital interface. Utilizing these standard digital interfaces can dramatically simplify power supply interfacing requirements saving the user both time and money, while enhancing functionality and overall capability. Spellman provides a GUI with the ST that allows the customer to both customize operational features of the ST while also providing basic power supply operational features. Details of the ST's digital interface capability are described in the ST manual, downloadable via the link on the first page of this data sheet.

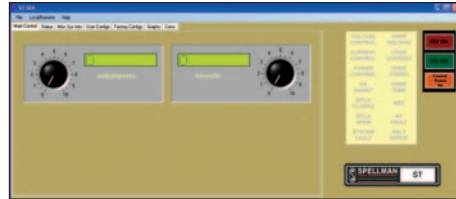

Main control screen



Status screen



User configuration screen

Arc Intervention

Spellman's ST power supplies have an arc intervention feature that senses arc currents via a fast acting current sense transformer. The purpose of the arc intervention circuitry is to prevent power supply damage from continuous, long term arcing. The factory default configuration will trip off the unit with an Arc Fault if 4 arcs occur in a 10 second time period. Customers can change basic arc intervention parameters (Arc Count, Arc Quench, Reramp Time, and Window Time) within preset limits via the digital interface interface; customized units can be provided for unique arc prone environments, contact Spellman for details.

ST SELECTION TABLE

MAXIMUM RATING		MODEL NUMBER
kV	mA	
1	12,000	ST1*12
2	6,000	ST2*12
3	4,000	ST3*12
4	3,000	ST4*12
6	2,000	ST6*12
8	1,500	ST8*12
10	1,200	ST10*12
12	1,000	ST12*12
15	800	ST15*12
20	600	ST20*12
30	400	ST30*12
40	300	ST40*12
50	240	ST50*12
60	200	ST60*12
70	171	ST70*12
80	150	ST80*12
100	120	ST100*12
120	100	ST120*12
150	67	ST150*10
225	40	ST225*10

*Substitute "P" for positive polarity and "N" for negative polarity. Polarity must be specified at time of order.
1-10kV units are inherently reversible by design requiring an internal wiring change to swap polarities. Intermediate voltage units are available by special order. 150kV and 225kV units are limited to a maximum output of 10kW's

NOTE: ST225 units cannot be paralled!

Parallel operation:

Additional power can be provided in increments of 12kW's by connecting chassis in parallel via the use of the ST's master/slave configuration.

Use the applicable base ST model number and increment the power denominated in 12kW steps as required.

- ST10P24** 10kV @ 24kW's
- ST10P36** 10kV @ 36kW's
- ST10P48** 10kV @ 48kW's



ST 1-150kV rear panel view



ST 225V rear panel view

JB1 ST ANALOG INTERFACE – 50 PIN FEMALE D CONNECTOR

PIN	SIGNAL	PARAMETERS
1	Power Supply Common	Power Supply Ground
2	Reset/HV Inhibit	Normally open, Low = Reset/Inhibit
3	External Interlock	+24Vdc @ open, <25mA @ closed
4	External Interlock Return	Return for External Interlock
5	mA Test Point	0-10Vdc = 0-100% rated output, Zout= 1KΩ, 1%
6	kV Test Point	0-10Vdc = 0-100% rated output, Zout= 1KΩ, 1%
7	+10Vdc Reference Output	+10Vdc @ 1mA
8	mA Program Input	0-10Vdc = 0-100% rated output, Zin>10MΩ
9	Local mA Program Output	0-10Vdc = 0-100% rated output, front panel pot
10	kV Program Input	0-10Vdc = 0-100% rated output, Zin>10MΩ
11	Local kV Program Output	0-10Vdc = 0-100% rated output, front panel pot
12	Remote Power On Output	+24Vdc @ open, 2A peak, 1Adc @ closed
13	Remote Power On Return	Return for Remote Power On
14	Remote HV Off	+24Vdc @ open, 2A peak, 1Adc @ closed, connect to pin15 for front panel operation
15	Remote HV Off/On Common	HV On/Off Common
16	Remote HV On	+24Vdc @ open, 2A peak, 1Adc @ closed, momentarily connect to pin 15 enable high voltage
17	HV Off Indicator	+24Vdc @ 25mA = HV Off
18	HV On Indicator	+24Vdc @ 25mA = HV On
19	Power Supply Common	Supply Ground
20	+24Vdc Output	+24Vdc @ 100mA, maximum
21	Voltage Mode Status	Open Collector, Low = Active
22	Current Mode Status	Open Collector, Low = Active
23	Power Mode Status	Open Collector, Low = Active
24	Interlock Closed Status	Open Collector, Low = Active
25	Power Test Point	0-10Vdc = 0-100% rated output, Zout= 5KΩ, 1%
26	Spare	
27	Spare	
28	Remote Overvoltage Adjust	0-10Vdc = 0-100% rated output
29	Over Power Fault	Open Collector, Low = Active
30	Over Voltage Fault	Open Collector, Low = Active
31	Over Current Fault	Open Collector, Low = Active
32	System Fault	Open Collector, Low = Active
33	RGLT Error Fault	Open Collector, Low = Active
34	Arc	Open Collector, Low = Active
35	Over Temp Fault	Open Collector, Low = Active
36	AC Fault	Open Collector, Low = Active
37	Spare	
38	Spare	
39	Spare	
40	Spare	
41	Spare	
42	Remote Power Program Input	0-10Vdc = 0-100% rated output, Zin>10MΩ
43	Local Power Program Output	0-10Vdc = 0-100% rated output, internal pot
44	+5Vdc Output	+5Vdc @ 100mA, maximum
45	+15Vdc Output	+15Vdc @ 100mA, maximum
46	-15Vdc Output	-15Vdc @ 10mA, maximum
47	RS232 Tx	
48	RS232 Rx	
49	RS232 GND	
50	Power Supply Common	Power Supply Ground

DIMENSIONS: in.[mm]

FRONT VIEW

ST 1kV-150kV

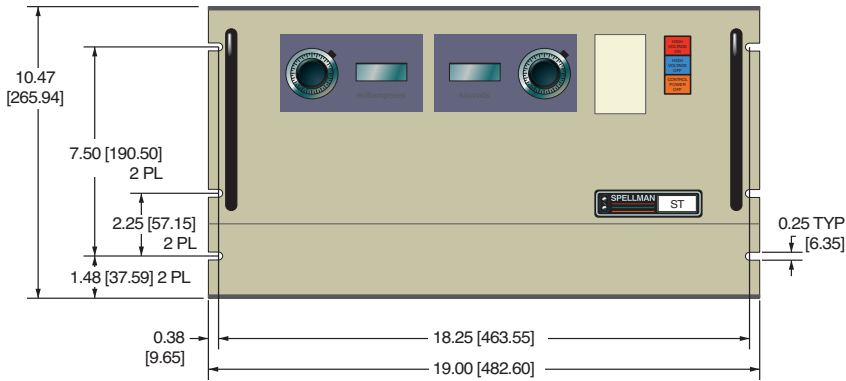

TOP VIEW

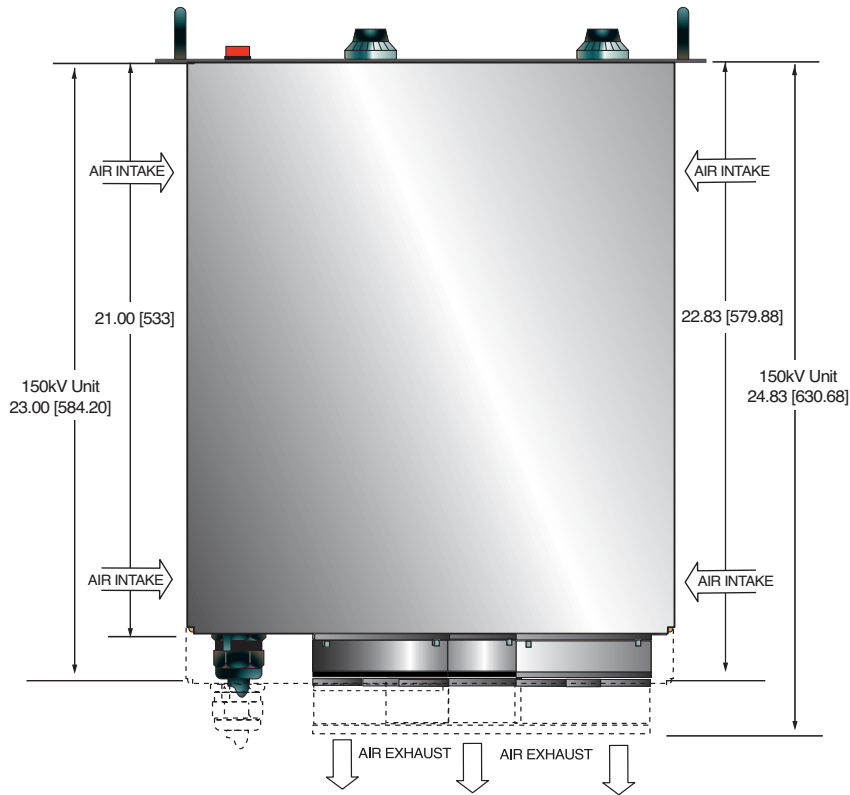

BACK VIEW

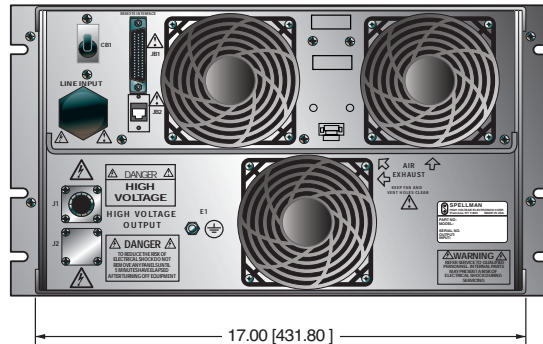

ST 225kV

DIMENSIONS: in.[mm]

TOP VIEW

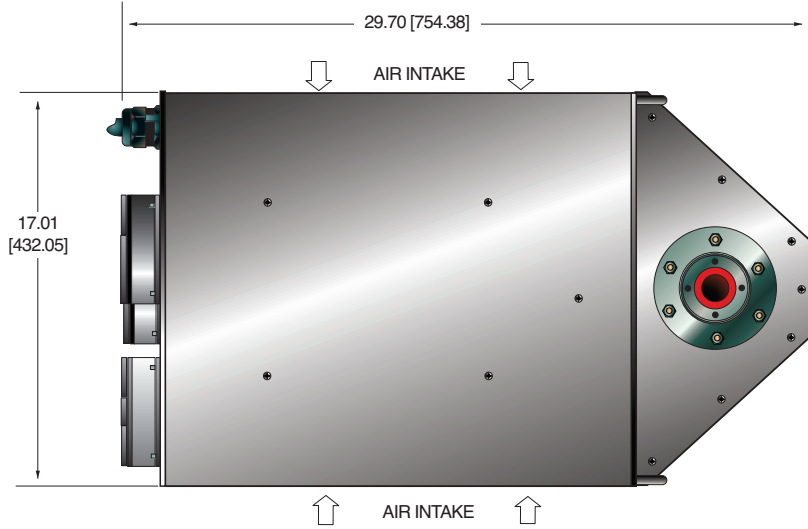

SIDE VIEW

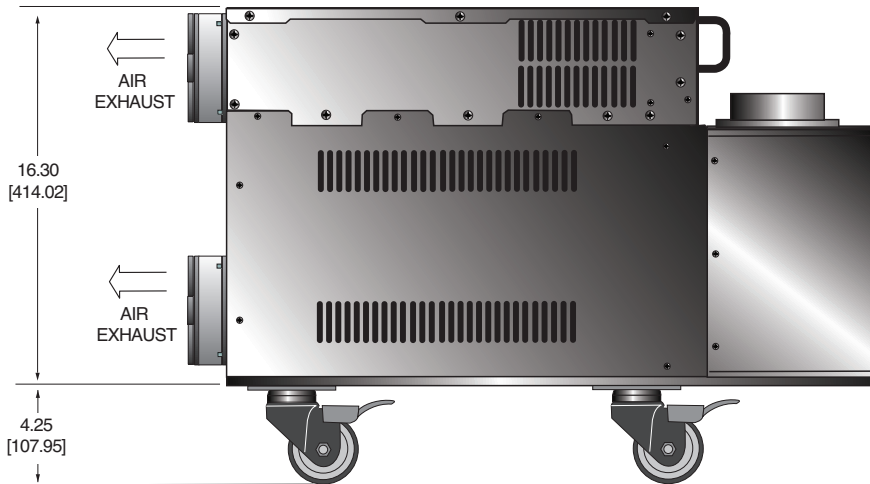

FRONT VIEW

NOTE:
Blank front
panel on
ST 225kV units

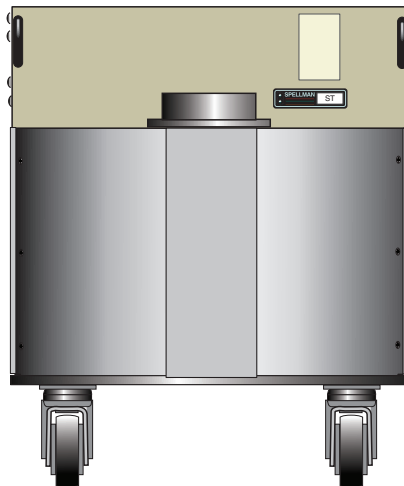

REAR VIEW





Spellman's XLG Series of X-Ray generators are well regulated high voltage power supplies with output voltages to 130kV and very low ripple achieved through the use of advanced resonant conversion techniques. Extremely stable voltage and emission current outputs result in significant performance improvements over previously available technology. The XLG Series provides all the power, control and support functions required for X-Ray applications including a regulated dc filament supply. These units incorporate local and remote programming, monitoring, safety interlock, short-circuit and overload protection.

TYPICAL APPLICATIONS

Plating Measurement
Mineral Analysis
X-Ray Fluorescence

OPTIONS

APT Adjustable Power Trip
AT Arc Trip
SS(x) Non-Standard Slow Start
NSS No Slow Start
IO Instant ON
LL(x) Extra Length HV Cable
SL Slides

FRONT PANEL STATUS INDICATORS:

Overvoltage	Voltage Control Mode
Overtemperature	Current Control Mode
Regulation Error	Interlock Open
Arc	Interlock Closed
HV ON: Red	HV OFF: Green

SPECIFICATIONS

Input Voltage:

115Vac \pm 10%, 50-60Hz single phase or
220Vac \pm 10%, 50-60Hz single phase.
For input current see table on page 2.

Voltage and Current Control:

Local: continuously adjustable from zero to maximum rating via a ten-turn potentiometer with a lockable counting dial.

Remote: 0 to +10Vdc proportional from 0 to full output.
Accuracy: \pm 1%. Input Impedance: 10Mohm.

- **Output Voltages to 130kV**
- **Integrated Ground Referenced Filament Supply**
- **Low Ripple**
- **"Hot Anode"**
- **Positive Polarity**
- **Local & Remote Programming**
- **OEM Customization Available**

www.spellmanhv.com/manuals/XLG

Filament:

Specify at time of order:

FH: 9A, 3V.

FL: 3A, 3V.

Preheat level is 0.45 amps in standby

Voltage Regulation:

Load: 0.005% of full output voltage no load to full load.

Line: 0.005% for input voltage range change.

Current Regulation:

Load: 0.05% of full current \pm 100 μ A from 0 to full voltage.

Line: 0.05% of rated current over specified input range.

Ripple:

0.03% rms below 1kHz.

0.75% rms above 1kHz.

Temperature Coefficient:

100ppm/ $^{\circ}$ C.

Stability:

0.01%/8 hrs after 1/2 hour warm-up.

0.02% per 8 hours (typical).

Cooling:

Free air convection.

Metering:

Digital voltage and current meters (3.5 digits),
1% accuracy.

HV Output Cable:

10' (3.3m) of shielded HV cable removable at rear.

I/O Connectors:

25 pin D-type for control interface with
mating connector provided.

Dimensions:

30 to 60kV:

3.5"H x 19"W x 19"D (8.9cm x 48.3cm x 48.3cm).

80 to 130kV:

3.5"H x 19"W x 24"D (8.9cm x 48.3cm x 61.0cm).

Regulatory Approvals:

Compliant to EEC EMC Directive. Compliant to EEC
Low Voltage Directive. RoHS Compliant.

Electronic Component (Power Source)

XLG series is intended for installation as a component of a system.

It is designed to meet CE standards, with conditions of acceptance often being: customer provided enclosure mounting, EMC filtering, and appropriate protection, and isolation devices. The XLG series is not intended to be operated by end users as a stand-alone device. The XLG series power supply can only be fully assessed when installed within a system, and as a component part within that system.

XLG INPUT CURRENT

MODEL	115Vac	220Vac
3W-30W	0.6A	0.3125A
40W-60W	1.2A	0.625A
70W-150W	3.0A	1.56A
160W-260W	5.25A	2.71A

XLG SELECTION TABLE 0.1mA, 0.2mA , 0.5mA

kV	0.1mA	0.2mA	.5mA
30	XLG30P3*	XLG30P6*	XLG30P15*
35	XLG35P3.5*	XLG35P7*	XLG35P17.5*
40	XLG40P4*	XLG40P8*	XLG40P20*
50	XLG50P5*	XLG50P10*	XLG50P25*
60	XLG60P6*	XLG60P12*	XLG60P30*
80	XLG80P8*	XLG80P16*	XLG80P40*
100	XLG100P10*	XLG100P20*	XLG100P50*
120	XLG120P12*	XLG120P24*	XLG120P60*
130	XLG130P13*	XLG130P26*	XLG130P65*

*Specify FH for High power (27W) filament, FL for Low power (9W) filament.

XLG SELECTION TABLE 1.0mA, 2.0mA, 3.0mA

kV	1.0mA	2.0mA	3.0mA
30	XLG30P30*	XLG30P60*	XLG30P90*
35	XLG35P35*	XLG35P70*	XLG35P105*
40	XLG40P40*	XLG40P80*	XLG40P120*
50	XLG50P50*	XLG50P100*	XLG50P150*
60	XLG60P60*	XLG60P120*	XLG60P180*
80	XLG80P80*	XLG80P160*	---
100	XLG100P100*	XLG100P200*	---
120	XLG120P120*	XLG120P240*	---
130	XLG130P130*	XLG130P260*	---

*Specify FH for High power (27W) filament, FL for Low power (9W) filament.

XLG CONNECTOR 25 PIN

PIN	SIGNAL	SIGNAL PARAMETERS
1	Power Supply Common	Signal Ground
2	External Inhibit	Ground=Inhibit, Open=HV On
3	External Interlock	+15V at Open, <15mA at Closed
4	External Interlock Return	Return for Interlock
5	Current Monitor	0 to 10V=0 to 100% Rated Output
6	kV Test Point	0 to 10V=0 to 100% Rated Output
7	+10V Reference	+10V, 1mA Max
8	Remote Current Program In	0 to 10V=0 to 100% Rated Output
9	Local Current Program Out	Front Panel Program Voltage
10	Remote Voltage Program In	0 to 10V=0 to 100% Rated Output
11	Local Voltage Program Out	Front Panel Program Voltage
12	Power Monitor	0 to 10V=0 to 100% Rated Output
13	Remote Power Program In	(Optional)
14	Local HV Off Out	+15V at Open, <25mA at Closed
15	HV Off	Connect to HV OFF for Fp Operation
16	Remote HV On	+15V, 10mA Max=HV Off
17	Remote HV Off Indicator	0=HV On, +15V, 10mA Max=HV Off
18	Remote HV On Indicator	0=HV Off, +15V, 10mA Max=HV On
19	Remote Voltage Mode	Open Collector 50V Max, 10mA Max
20	Remote Current Mode	
21	Remote Power Mode	On=Active
22	Remote PS Fault	0=Fault, +15V, 0.1mA Max=No Fault
23	+15V Output	+15V, 100mA Max
24	Power Supply Common	Signal Ground
25	Shield Return	Shield Return

DIMENSIONS: in.[mm]

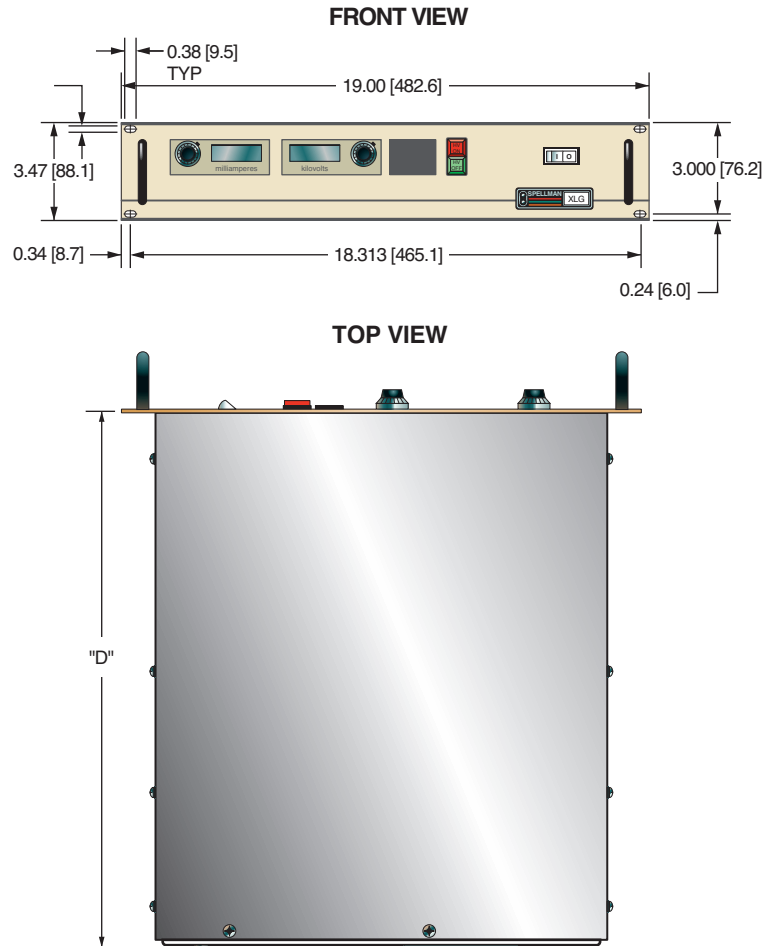

BACK VIEW

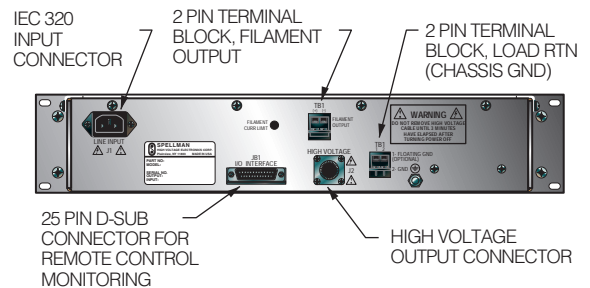



- **Output Voltage 20V to 10kV**
- **Integrated Floating Filament Supply**
- **Low Ripple**
- **Local and Remote Programming**
- **OEM Customization Available**

The XMPF is a modular 10kV @ 5W X-Ray generator designed to drive a floating filament X-Ray tube via closed loop filamentary control of the 0 to 500uA emission current. The floating filament supply is rated at 0 to 0.42 amps @ 3.5Vac. The filament supply features an adjustable 0 to 0.42 amp filament limit.

The high voltage program and emission current program have internal preset capability simplify interfacing to this X-Ray generator. Alternatively, a customer provided 0 to 10Vdc signal can be used to remotely control these two signals. A high voltage monitor signal and emission current monitor signal is provided. Additionally a filament current monitor signal is also provided. A High Voltage Enable input provides control of the high voltage output.

SPECIFICATIONS

Input Voltage:

+24 Vdc, ±10%

Input Current:

500mA maximum

Cathode Supply:

Voltage: 10kV, controllable over the range 20V to 10kV

Accuracy: <2%

Polarity: Negative

Line Regulation: <0.05% for input voltage change of ±10%

Load Regulation: <0.1% for zero to full load

Stability: <0.1% per 24 hours at constant operating conditions, after 30 minutes warm up

Temperature Coefficient: <250 ppm/°C

Ripple: <0.01% p-p of output voltage at full voltage and current

Output Current Limit: 550µA ±10%

Ramp Rate: <20kV/sec

Current Characteristics:

Maximum Emission Current: 500uA

Stability: 0.5% using the internal reference and setting potentiometer. For increased stability an external reference can be used.

Filament Supply:

Voltage: 0V to 3.5Vac referenced to Cathode output

Load Current: 0.42A max, pre set adjustable limit

Stability: <0.1% over a 30 minute period at constant operating conditions.

Environmental:

Temperature Range:

Operating: 5°C to 40°C

Storage: -40°C to 70°C

Humidity:

Operating: 20% to 80% RH, non-condensing

Storage: 5% to 95%

High Voltage Output:

Flying leads, Reynolds 18kV rated FEP insulated wire, 1.02mm diameter. Conductors are 19/40 AWG. Overall length is 500mm, the two wires are sleeved together.

Dimensions:

1.18"H x 2.75"W x 6.69"D

(30mm x 70mm x 170mm)

Regulatory Approvals:

Compliant to CE Safety marking to meet the requirements of EN61010, Installation cat II, safety class 1, poll. degree 2 and UL61010A-1 and CSA 1010. RoHS compliant.

As the unit is designed for incorporation within the users system it is not tested against any specific EMC standards. The user will need to take sensible EMC precautions when designing the unit in and verify the overall system EMC performance against any relevant standards.

CUSTOMER INTERFACE— 15 PIN MALE D CONNECTOR

PIN	SIGNAL	SIGNAL PARAMETERS
1	+24Vdc	+24Vdc @ 500mA, max.
2	Power Ground	Power Ground
3	N/C	N/C
4	Signal Ground	Signal Ground
5	HV Enable	0-0.8V = HV ON, 2.4V-12V = HV OFF
6	N/C	N/C
7	HV Program Output	Wiper of multi turn potentiometer
8	HV Program Input	0-10Vdc = 0-10kV, Zin = 10MΩ, accuracy ±2% of FS
9	High Voltage Monitor	0-10Vdc = 0-10kV, Zout = 10kΩ, accuracy ±2% of FS
10	Emission Current Monitor	0-10Vdc = 0-500uA, Zout = 10kΩ, accuracy ±3% of FS
11	Filament Current Monitor	0-10Vdc = 0-500mA, Zout = 10kΩ, accuracy ±5% of FS
12	Emission Current Program Input	0-10Vdc = 0-500uA, Zin = 10MΩ, accuracy ±3% of FS
13	Emission Current Program Output	Wiper of multi turn potentiometer
14	Signal Ground	Signal Ground
15	Filament Current Limit	

The filament current limit is set by internal preset potentiometers accessible through the side of the case.

If external high voltage programming is not required link pins 7 and 8.
If external emission current control is not required link pins 12 and 13.

DIMENSIONS: in.[mm]

FRONT VIEW

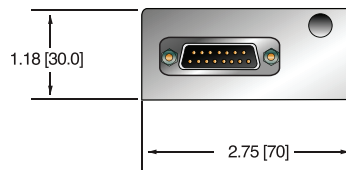

TOP VIEW

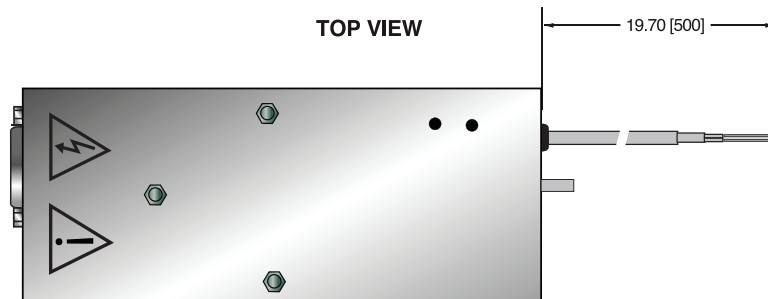

SIDE VIEW



BOTTOM VIEW

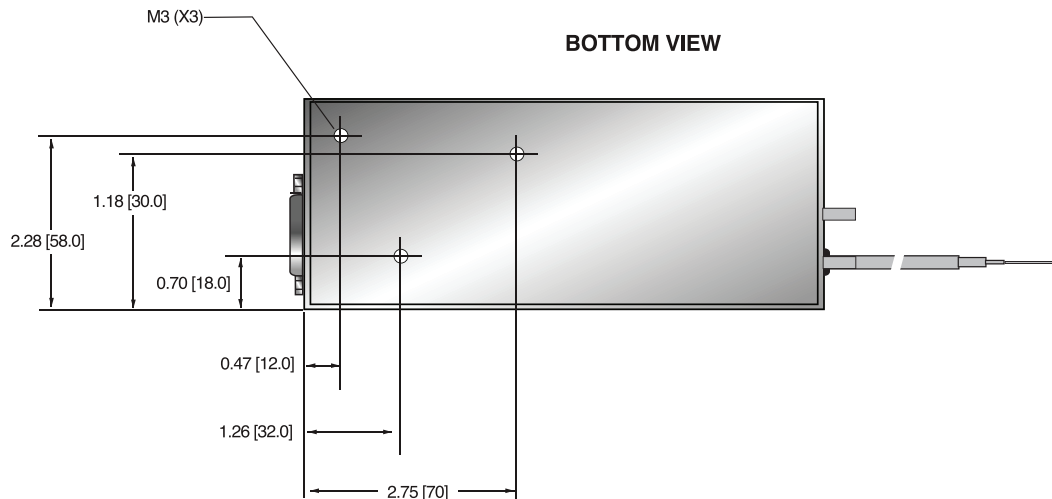



The XMPG is a modular 10kV @ 10W X-Ray generator designed to drive a grounded filament X-Ray tube via closed loop filamentary control of the 0 to 1mA emission current. The grounded filament supply is rated at 0-5 amps @ 3Vdc. The filament supply features an internally adjustable 0.5 to 2.5 amp filament preheat and a internally adjustable 0 to 5 amp filament limit.

The high voltage program and emission current program have internal preset capability simplify interfacing to this X-Ray generator. Or a customer provided 0 to 10Vdc signal can be used to remotely control these two signals. A high voltage monitor signal and emission current monitor signal is provided. A High Voltage Enable input provides control of the high voltage output and a Filament Stable output indicates the filament current is stable and the X-Ray tube is producing X-Rays.

SPECIFICATIONS

Input Voltage:

+24 Vdc, $\pm 10\%$

Input Current:

2 amp maximum

Output Voltage:

10kV, controllable over the range 4kV to 10kV

Voltage Accuracy:

<2%

Polarity:

Positive

Voltage Regulation:

Line: <0.01% for input voltage change of $\pm 10\%$

Load: <0.01% for zero to full load

Voltage Stability:

< 0.1% per 24 hours at constant operating conditions, after 30 minutes warm up

Ripple:

< 500mV p-p of output voltage at full load

Ramp Rate:

< 20kV/second

Temperature Coefficient:

<250ppm per degree C

- **Output Voltage 4kV to 10kV**
- **Integrated Ground Referenced Filament Supply**
- **Low Ripple**
- **Local and Remote Programming**
- **OEM Customization Available**

Current Regulation:

Line: $\leq 0.01\%$ for 1V input voltage change under any load conditions

Load: $\leq 0.01\%$ for full load to short circuit

Emission Current:

0-1mA

Current Accuracy:

<1% (above 10% of maximum output current)

Current Stability:

< 0.02%

Environmental:

Temperature Range:

Operating: 5°C to 40°C

Storage: -40°C to 70°C

Humidity:

Operating: 20% to 80% RH, non-condensing

Storage: 5% to 95%

Filament Supply:

Voltage: 0V to 3Vdc referenced to ground

Load Current: 5A max, preset adjustable limit

Stability: < 0.25% per 8 hours at constant operating conditions

Ripple: <50mV p-p (at maximum load current).

Temperature Coefficient: <300ppm/°C

Filament Output:

A captive 500mm long unterminated 16 AWG twisted wire pair is provided.

High Voltage Output:

A captive 500mm long unterminated length of URM76 shielded cable

A red High Voltage On LED is provided next to the high voltage output to indicate that high voltage is being produced by the unit

Dimensions:

1.31"H x 4.13"W x 7.28"D (33.5mm x 105mm x 185mm)

Regulatory Approvals:

Compliant to CE Safety marking to meet the requirements of EN61010, Installation cat II, safety class 1, poll. degree 2 and UL61010A-1 and CSA 1010.

As the unit is designed for incorporation within the users system it is not tested against any specific EMC standards. The user will need to take sensible EMC precautions when designing the unit in and verify the overall system EMC performance against any relevant standards. RoHS compliant.

FILAMENT OUTPUT

COLOR	NAME
Red	Filament +
Black	Filament -

CUSTOMER INTERFACE – 15 PIN MALE D CONNECTOR

PIN	SIGNAL	SIGNAL PARAMETERS
1	+24Vdc	+24Vdc
2	Ground	Ground
3	Preheat (set value)	0-5Vdc from internal preset
4	Test (Filament Current Direct Program)	Do not connect
5	HV Enable	Digital Input
6	Filament Stable	Digital Output
7	HV Program Output	0-10Vdc from Internal Preset
8	HV Program Input	0-10Vdc Input
9	High Voltage Monitor	0-10Vdc Output
10	Emission Current Monitor	0-10Vdc Output
11	Filament Current Monitor	0-10Vdc Output
12	Emission Current Program Input	0-10Vdc Input
13	Emission Current Program Output	0-10Vdc from Internal Preset
14	Ground	Ground
15	Preset Max. Filament Current (set value)	0-10Vdc from Internal Preset

The filament Preheat level and current limit are set by internal preset potentiometers accessible through the side of the case.
 If external high voltage enable control is not required link pins 7 and 8.
 If external emission current control is not required link pins 12 and 13.

DIMENSIONS: in.[mm]

FRONT VIEW

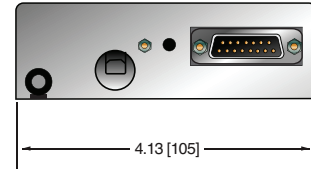

TOP VIEW

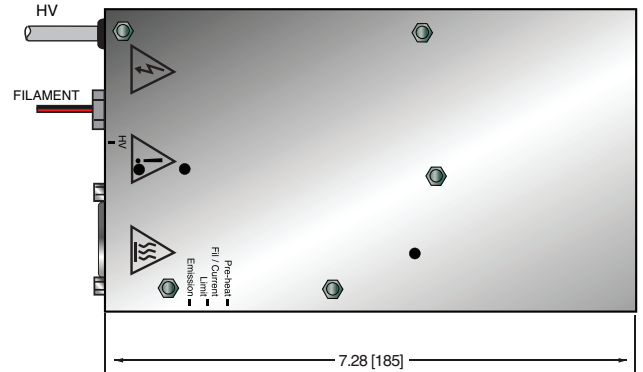

BOTTOM VIEW

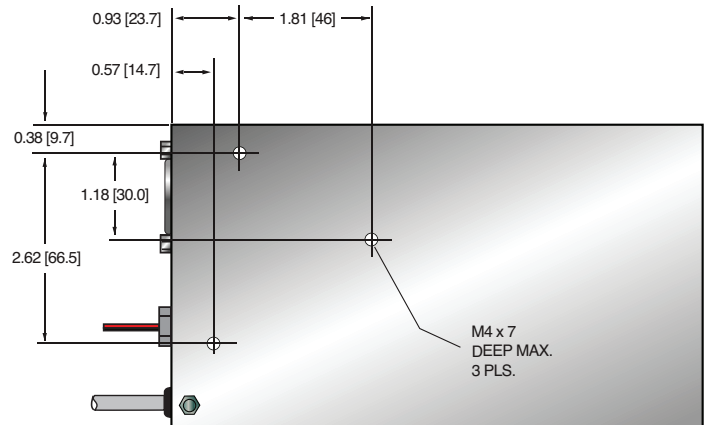

SIDE VIEW

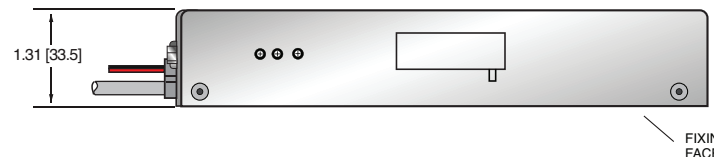



Ask about our X-Ray subsystem capabilities

- **50kV at 2mA, 50 or 75 Watt Max**
- **65kV at 2mA, 65 Watt Max**
- **Adjustable Integrated Filament Supply**
- **Arc & Short Circuit Protection**
- **Voltage & Current Programming**
- **Local and Remote Emission Control**
- **Safety Interlock**
- **OEM Customization Available**
- **CE Marked, UL Recognized**

www.spellmanhv.com/manuals/MNX

The MNX Series is the result of Spellman's exceptional high voltage packaging and surface mount fabrication techniques coupled with proprietary encapsulation technology producing this ultra-compact X-Ray generator module. The MNX powers grounded cathode X-Ray tubes from a variety of well-known manufacturers, featuring a 0 to 50kV/65kV high voltage output @ 2mA limited to 50, 65 or 75 Watts. The MNX uses closed loop filament control circuitry providing highly regulated beam current. The ground referenced low noise dc filament supply operates between 0.3 and 3.5 amps. Offering tight regulation, high stability and low ripple, the MNX provides users local and remote analog control to set beam voltage, emission current and filament current limit.

TYPICAL APPLICATIONS

Powering grounded cathode X-ray tubes from KeveX, Oxford, RTW, Superior, Varian, Petrick and Trufocus.

OPTIONS

- XCC** XRM Compatible HV Cable (50kV only)
- 5VPM** 0 to 5 Volt Programming and Monitor Scaling
- 5302** Mammoflex HV cable for MNX
- 2001** Mammoflex HV cable for MNX w/XCC option

SPECIFICATIONS

Input Voltage:

+24Vdc $\pm 10\%$, for 50W or 75W units
+24Vdc $\pm 1V$, for 65kV @ 65W unit

Input Current:

MNX50P50: 4.0 amps, maximum
MNX50P75: 6.0 amps, maximum
MNX65P65: 5.0 amps, maximum
GB Option: 1.0 amp additional, maximum

Efficiency:

80-85%, typical

Output:

0 to 50kV at 0 to 2mA, limited to a maximum of 50 watts or 75 Watts. 0-65kV at 2mA limited to 65 Watts.

Voltage Control:

Local: Internal multi-turn potentiometer to set voltage from 0 to full output voltage.
Remote: 0 to +10Vdc proportional from 0 to full output voltage. Accuracy: $\pm 1\%$. Z_{IN} : 10Mohm.

Emission Control:

Local: Internal potentiometer to set beam current between 0 and full output current.
Remote: 0 to +10Vdc proportional from 0 to full output current. Accuracy: $\pm 1\%$. Z_{IN} : 10Mohm. Filament limit and filament preheat control capability is also provided.

DC Filament Supply:

Current: 3.5A, adjustable limit
Voltage: 5.0 volt limit

Voltage Regulation:

Load: 0.01% of output voltage no load to full load.
Line: $\pm 0.01\%$ for $\pm 10\%$ change in input voltage.

Current Regulation:

Load: 0.01% of output current from 0 to rated voltage.
Line: $\pm 0.01\%$ for $\pm 10\%$ change in input voltage.

Ripple:

0.1% p-p of maximum rated output voltage, 50kV units (50/75W)
0.1% rms maximum rated output voltage, 65kV units (65W)

Environmental:

Operational: 0°C to +50°C
Storage: -40°C to +85°C
Humidity: 0% to 90%, non-condensing

Temperature Coefficient:

0.01% per °C, voltage and current.

Stability:

0.05% per 8 hours after 1/2 hour warm-up.

Voltage and Current Monitors:

0 to +10Vdc proportional from 0 to rated output. Accuracy $\pm 1\%$.

Dimensions:

50kV Unit: 5.00"H x 2.87"W x 8"D
(127.00mm x 72.90mm x 203.25mm)
65kV Unit: 5.00"H x 2.87"W x 9"D
(127.00mm x 72.90mm x 228.65mm)
XCC Option: 5.00"H x 2.87"W x 9"D (50/75W units only)
(127.00mm x 72.90mm x 228.65mm)

Weight:

6.5 lbs. (2.9kg)

Regulatory Approvals:

Compliant to EEC EMC Directive. Compliant to EEC Low Voltage Directive. UL/CUL recognized, File E227588; MNX65P65 is not UL/CUL recognized. RoHS Compliant.

X-Ray Tubes

The MNX powers grounded cathode X-Ray tubes from manufacturers such as Varian Medical Systems, Petrick GmbH and others.



VARIAN
medical systems



Petrick GmbH

DIMENSIONS: in.[mm]

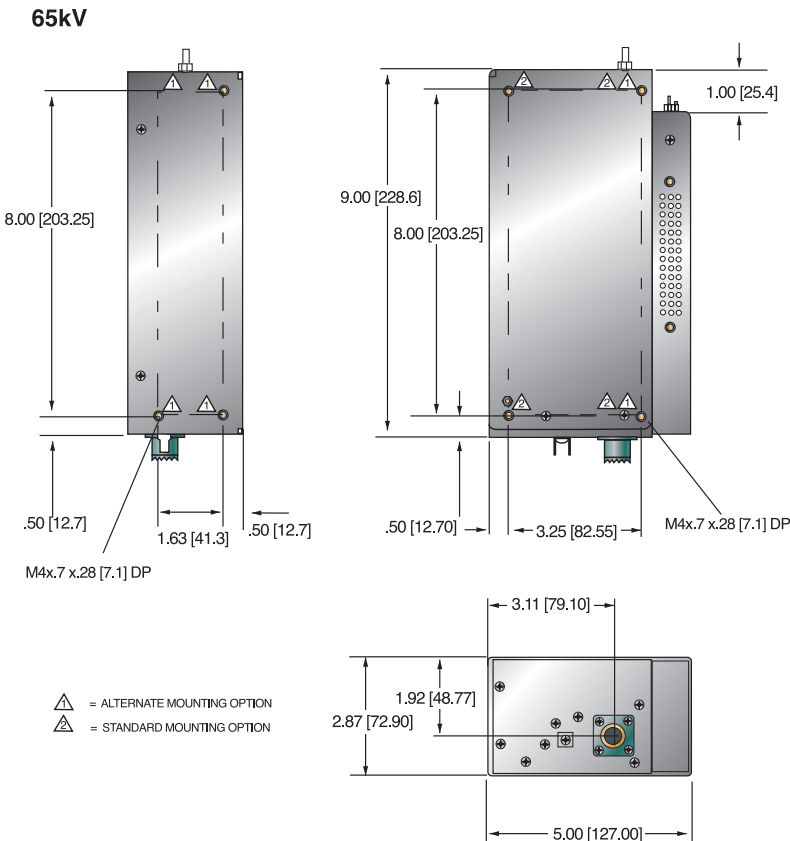

J2 POWER INPUT CONNECTOR

PIN	SIGNAL	PARAMETER
1	+24V Input	+24 volts @ 5A, max.
2	24V Return (Gnd.)	Power Ground

J3 FILAMENT CONNECTOR

PIN	SIGNAL	PARAMETER
1	Filament Out	0.3A to 3.5A, 5 volt, max.
2	Filament Return	Filament Ground

J4 ANALOG INTERFACE CONNECTOR MALE 15 PIN MINI "D"

PIN	SIGNAL	PARAMETER
1	Monitor Return	Signal Ground
2	Voltage Monitor	0-10 volts = 0 to full scale, Zout=1KΩ
3	Current Monitor	0-10 volts = 0 to full scale, Zout=1KΩ
4	Interlock Output	Connect 12V HVON bulb to pin 15 to enable
5	+10 Volt Reference	+10 Volts at 1mA, maximum
6	Filament Monitor	1 volt = 1 amp, Zout=1KΩ
7	Voltage Program Input	0-10 volts = 0 to full scale, Zin=10MΩ
8	Local Voltage Program*	0-10 volts, screwdriver adjust
9	Filament Limit Setpoint*	1 volt = 1 amp, screwdriver adjust
10	Current Program Input	0-10 volts = 0 to full scale, Zin=10MΩ
11	Local Current Program*	10 turn pot, screwdriver adjust
12	Not used (+24V Out for Interlock)	(Optional Interlock configuration)
13	Not used (Interlock Coil)	(Optional Interlock configuration)
14	Filament Preheat Setpoint*	1 volt = 1 amp, screwdriver adjust
15	Interlock Return	Interlock Ground

*Denotes 10 turn potentiometer located on front panel

J1 HIGH VOLTAGE OUTPUT CONNECTOR

Spellman drywell type detachable connector.

Standard: A one meter (39.4") long polyethylene mating high voltage cable is provided.

5302: A one meter (39.4") long Mammoflex mating high voltage cable is provided, SHV p/n 201946-007

2001: A one meter (39.4") long Mammoflex mating high voltage cable is provided, compatible with the XCC Option SHV p/n 201946-002

Drywell connector depth:

50kV: 7.25"

65kV: 8.25"

XCC Option: 8.25"

How To Order:

Sample model number:

50 Watt unit: MNX50P50

65 Watt unit: MNX65P65

75 Watt unit: MNX50P75

Options are added to the model number as follows:

MNX50P50/XCC

DIMENSIONS: in.[mm]

50kV

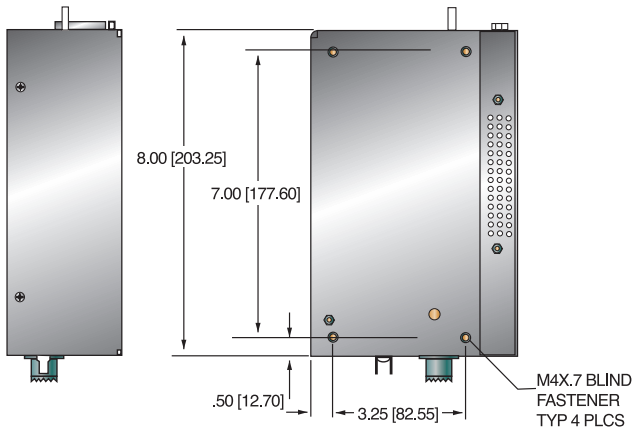

50kV with XCC Option

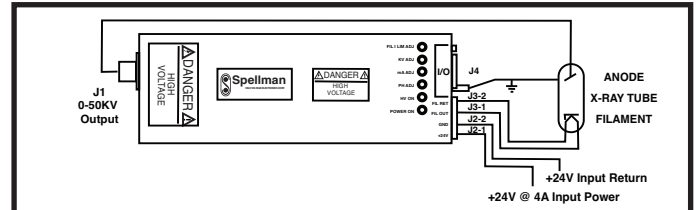
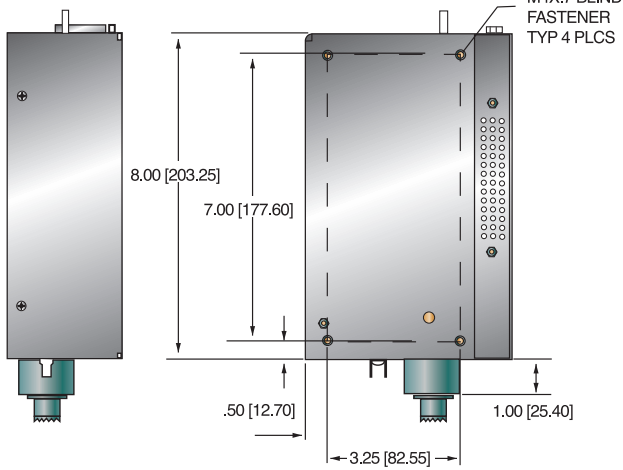

Typical MNX Operating Setup

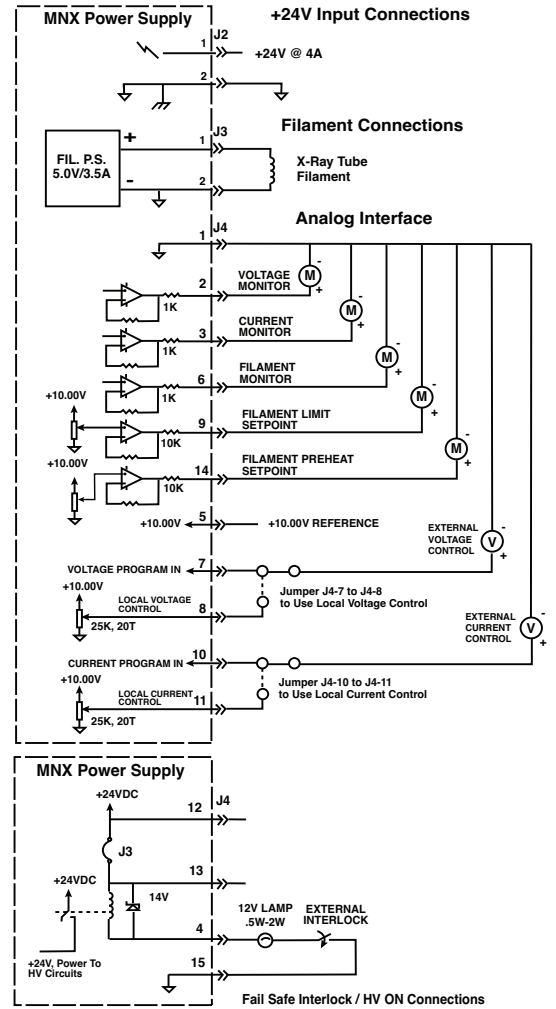

Alternate Interlock Configurations

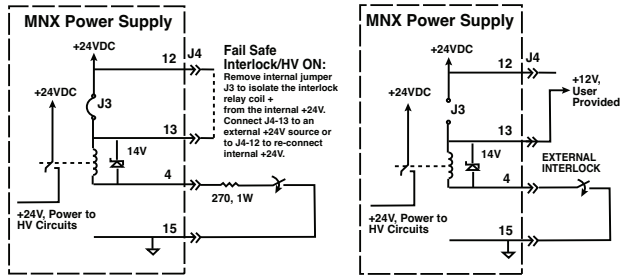

Alternate Interlock Configuration: Fail Safe Lamp Replaced With a 270 Ohm Resistor
Alternate Interlock Configuration: Customer Provided +12V For HV ON Relay, Relay Return Grounded



30% Smaller
than MNX



Ask about our X-Ray subsystem capabilities

- **50kV at 2 mA. 50 or 75 Watt Max.**
- **65kV at 2 mA. 65 Watt Max.**
- **Adjustable Isolated Filament Supply**
- **Overvoltage & Short Circuit Protection**
- **Voltage & Current Programming**
- **Local and Remote Emission Control**
- **Safety Interlock**
- **RS-232, Ethernet, & USB Standard**
- **Redundant HV Monitor Signal Available**
- **OEM Customization Available**

The uX Series is the result of Spellman's exceptional high voltage packaging and surface mount fabrication techniques coupled with proprietary encapsulation technology producing this ultra-compact X-Ray generator module. The uX powers grounded cathode X-Ray tubes from a variety of well-known manufacturers, featuring a 0 to 50kV/65kV high voltage output @ 2mA limited to 50, 65 or 75 Watts. The uX uses closed loop filament control circuitry providing highly regulated beam current. The low noise dc filament supply operates between 0.3 and 3.5 amps. Offering tight regulation, high stability and low ripple, the uX provides users local and remote analog control to set beam voltage, emission current and filament current limit. USB, RS-232 and Ethernet interface is standard.

TYPICAL APPLICATIONS

Powering grounded cathode X-Ray tubes from Kevex, Oxford, RTW, Superior, Varian and Trufocus.

OPTIONS

XCC	XRM Compatible HV Cable (50kV only)
5VPM	0 to 5 Volt Programming and Monitor Scaling
GB	Grid Bias
GF	Grounded Filament
5302	Mammoflex HV cable for uX
2001	Mammoflex HV cable for uX w/XCC option

SPECIFICATIONS

Input:

+24Vdc \pm 10%, 5.0A maximum for either 50 Watts or 75 Watts.
+24Vdc \pm 1V, 5.0A maximum for 65kV/65W units.

Efficiency:

75%, typical

Output:

0 to 50kV at 0 to 2mA, limited to a maximum of 50 watts or 75 Watts. 0-65kV at 2mA limited to 65 Watts.

Voltage Control:

Local: Internal multi-turn potentiometer to set voltage from 0 to full output voltage.

Remote: 0 to +10Vdc proportional from 0 to full output voltage.
Accuracy: \pm 1%. Z_{IN} : 10Mohm.

Emission Control:

Local: Internal potentiometer to set beam current between 0 and full output current.

Remote: 0 to +10Vdc proportional from 0 to full output current.
Accuracy: \pm 1%. Z_{IN} : 10Mohm. Filament limit and filament preheat control capability is also provided.

DC Filament Supply:

Isolated filament power supply generates emission current feedback signal for accurate low X-Ray tube current performance.

Current: 3.5A, adjustable limit
Voltage: 5.0 volt limit

Environmental:

Operational: 0°C to +50°C
Storage: -40°C to +85°C
Humidity: 0% to 90%, non-condensing

Temperature Coefficient:

0.01% per °C, voltage and current.

Stability:

0.05% per 8 hours after 1/2 hour warm-up.

Voltage and Current Monitors:

0 to +10Vdc proportional from 0 to rated output. Accuracy \pm 1%.

Redundant Voltage Monitor:

A redundant high voltage feedback divider with proportional 0 to +10Vdc = 0 to 100% output voltage signal can be provided on a custom basis.

Dimensions:

50kV Unit: 4.00"H x 2.87"W x 8.00"D
(101.6mm x 72.95mm x 202.20mm).
65kV Unit: 4.00"H x 2.87"W x 9.00"D
(101.6mm x 72.95mm x 228.60mm).
XCC Option: 4.00"H x 2.87"W x 9.00"D
(101.6mm x 72.95mm x 228.60mm).

Weight:

4.5 lbs. (2.1kg) typical

Regulatory Approvals:

Compliant to EEC EMC Directive. Compliant to EEC Low Voltage Directive. RoHS Compliant. UL/CUL recognized, File E227588

X-Ray Tubes

The uX powers grounded cathode X-Ray tubes from manufacturers such as Varian Medical Systems, Petrick GmbH and others.



VARIAN
medical systems

Petrick GmbH

Digital Interface

The uX features a standard USB, RS-232 and Ethernet digital interface. Utilizing these standard digital interfaces can dramatically simplify power supply interfacing requirements saving the user both time and money, while enhancing functionality and overall capability. Spellman provides a GUI with the uX that allows the customer to both customize operational features of the uX while also providing basic power supply operational features. Details of the uX's digital interface capability are described in detail in the uX manual.



Closeup showing digital interface connectors



Main Control Screen



Filament Status Screen

Grid Bias Option (GB):

Plug-n-Play compatibility for Oxford's Apogee X-Ray Tube Spellman's Grid Bias Option for the uX Series is specifically designed for popular commercially available grid bias X-Ray tubes. The Grid Bias voltage is developed via the use of separate integrated high frequency switching circuit, providing maximum flexibility and control. The Grid Bias output is a voltage regulated, current compliant topology ideally suited for Wehnelt electrode applications. Arc and short circuit protection of the Grid Bias output prevents any damage due to transient events or installation errors.

Tracking Mode Operation

Functioning in tracking mode the voltage monitor (0-10Vdc = 0 to 50kV) of the main high voltage output is internally connected to the Grid Bias programming input (0-10Vdc = 0 to -300Vdc of Grid Bias). Connected in this manner the Grid Bias output will track in a linearly proportional fashion the setting of the main KV output.

A multiturn potentiometer limits the maximum magnitude of Grid Bias output applied to the X-Ray tube, providing unparalleled flexibility.

The output of the Grid Bias option is provided via an auxiliary two position Phoenix Contact terminal block, the mating connector is provided.

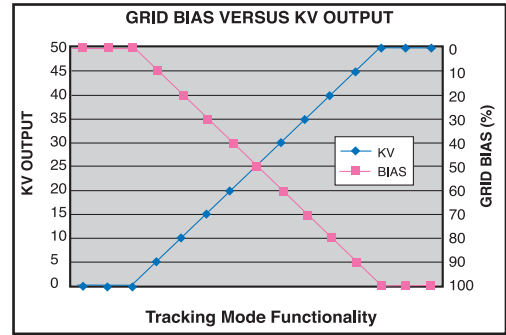

GRID BIAS SPECIFICATIONS

- Output Voltage:** 0 to -300Vdc
- Output Current:** 0.25mA, maximum
- Load Regulation:** 1% of output voltage, no load to full load
- Line Regulation:** 1% for a ±10% change in input voltage
- Ripple:** 1% of maximum rated voltage

uX with Grid Bias Option.
Shown with Oxford Apogee X-Ray Tube (not included)



Note: Units ordered with the GB Option will be provided with the XCC Option for proper high voltage cable compatibility.



HIGH VOLTAGE OUTPUT CONNECTOR

Spellman drywell type detachable connector.

Standard: A one meter (39.4") long polyethylene mating high voltage cable is provided.

5302: A one meter (39.4") long Mammoflex mating high voltage cable is provided, SHV p/n 201946-007

2001: A one meter (39.4") long Mammoflex mating high voltage cable is provided, compatible with the XCC Option SHV p/n 201946-002

GRID BIAS CONNECTOR 2 PIN PHOENIX CONTACT

PIN	SIGNAL	PARAMETER
1	Ground	Chassis Ground
2	Grid Bias	0 to -300Vdc

USB DIGITAL INTERFACE— 4 PIN USB “B” CONNECTOR

PIN	SIGNAL	PARAMETER
1	VBUS	+5 Vdc
2	D-	Data -
3	D+	Data +
4	GND	Ground

POWER INPUT/FILAMENT CONNECTOR 4 PIN PHOENIX CONTACT

PIN	SIGNAL	PARAMETER
1	+24V Input	+24 volts @ 5A, max.
2	24V Return (Gnd.)	Power Ground
3	Filament Out	0.3A to 3.5A, 5 volt, max.
4	Filament Return	Filament Return

Note: On the standard uX unit, the filament return wire cannot be grounded as this would short circuit the tube return current monitoring to the uX. If grounding of the filament is required, please select the GF (Grounded Filament) option when ordering.

ETHERNET DIGITAL INTERFACE— 8 PIN RJ45 CONNECTOR

PIN	SIGNAL	PARAMETER
1	TX+	Transmit Data +
2	TX-	Transmit Data -
3	RX+	Receive Data +
4	NC	No Connection
5	NC	No Connection
6	RX-	Receive Data -
7	NC	No Connection
8	NC	No Connection

ANALOG INTERFACE CONNECTOR MALE 15 PIN MINI “D”

PIN	SIGNAL	PARAMETER
1	Monitor Return	Signal Ground
2	Voltage Monitor	0-10 volts = 0 to full scale, Zout=1KΩ
3	Current Monitor	0-10 volts = 0 to full scale, Zout=1KΩ
4	Interlock Output	Connect 12V HVON bulb to pin 15 to enable
5	+10 Volt Reference	+10 Volts at 1mA, maximum
6	Filament Monitor	1 volt = 1 amp, Zout=1KΩ
7	Voltage Program Input	0-10 volts = 0 to full scale, Zin=10MΩ
8	Local Voltage Program*	0-10 volts, screwdriver adjust
9	Filament Limit Setpoint*	1 volt = 1 amp, screwdriver adjust
10	Current Program Input	0-10 volts = 0 to full scale, Zin=10MΩ
11	Local Current Program*	10 turn pot, screwdriver adjust
12	Not used (+24V Out for Interlock)	(Optional Interlock configuration)
13	Not used (Interlock Coil)	(Optional Interlock configuration)
14	Filament Preheat Setpoint*	1 volt = 1 amp, screwdriver adjust
15	Interlock Return	Interlock Ground

*Denotes 10 turn potentiometer accessible through holes in cover

RS-232 DIGITAL INTERFACE— 9 PIN FEMALE D CONNECTOR

PIN	SIGNAL	PARAMETER
1	NC	No Connection
2	TX out	Transmit Data
3	RX in	Receive Data
4	NC	No Connection
5	SGND	Ground
6	NC	No Connection
7	NC	No Connection
8	NC	No Connection
9	NC	No Connection

How To Order:

Sample model number:

50 Watt unit: uX50P50

65 Watt unit: uX65P65

75 Watt unit: uX50P75

Options are added to the model number as follows:
uX50P50/XCC or uX50P75/GB

Ask about our X-Ray subsystem capabilities

DIMENSIONS: in.[mm]

50kV

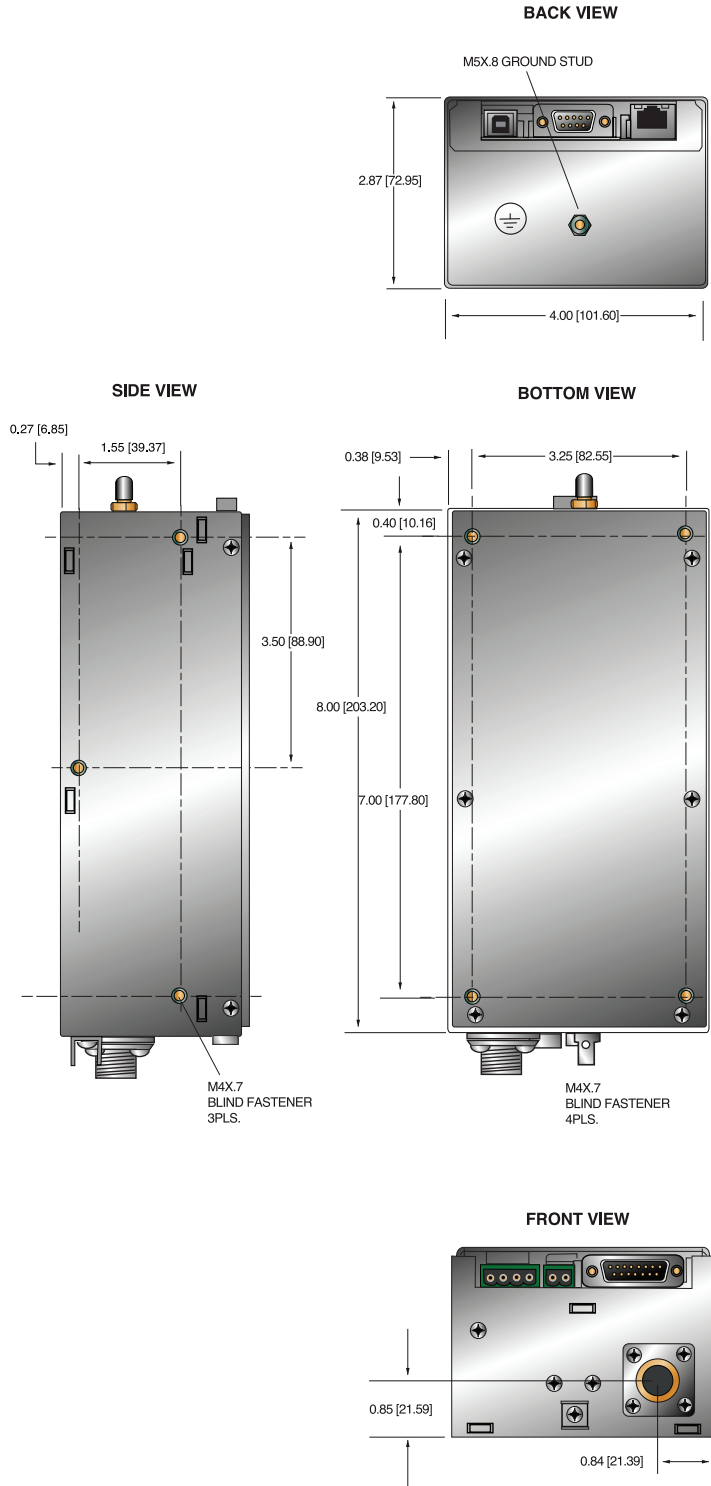

50kV with XCC Option

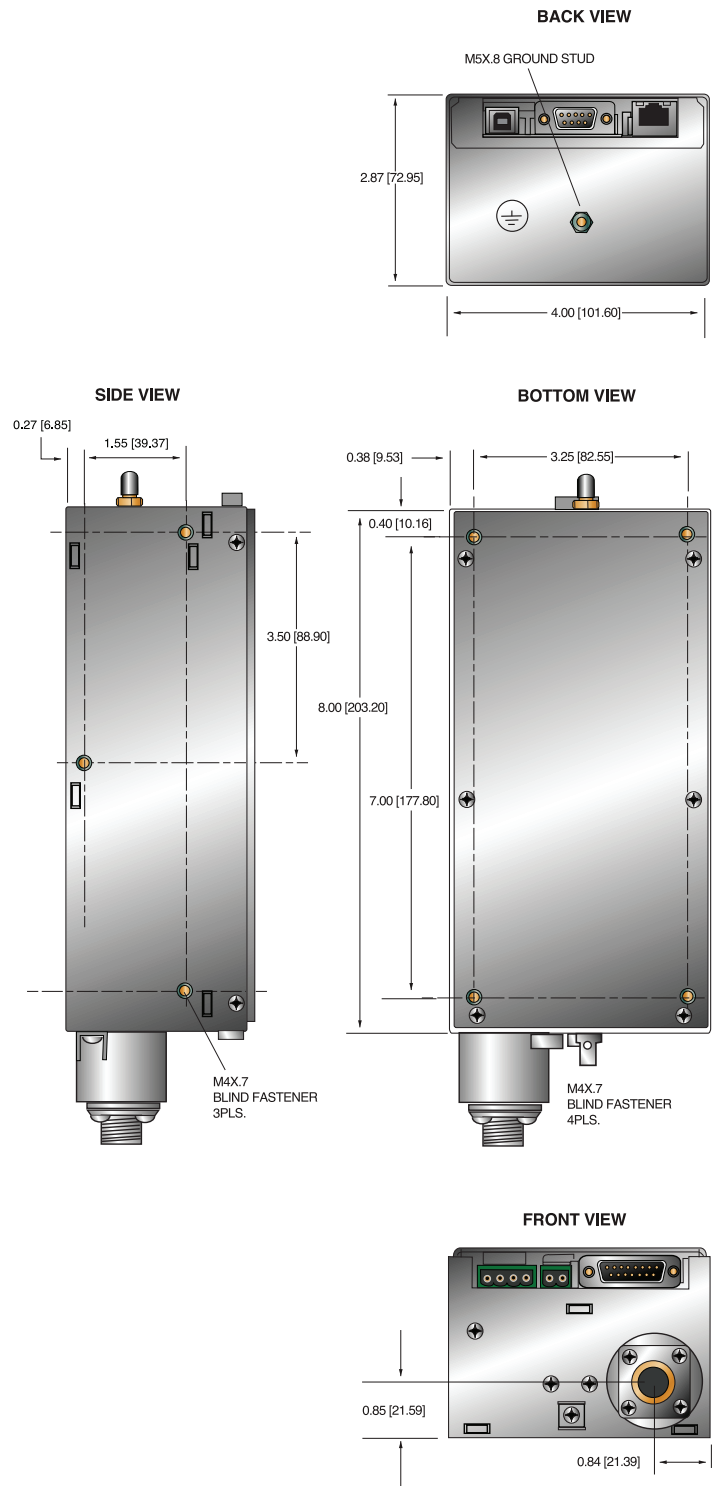

DIMENSIONS: in.[mm]

65kV

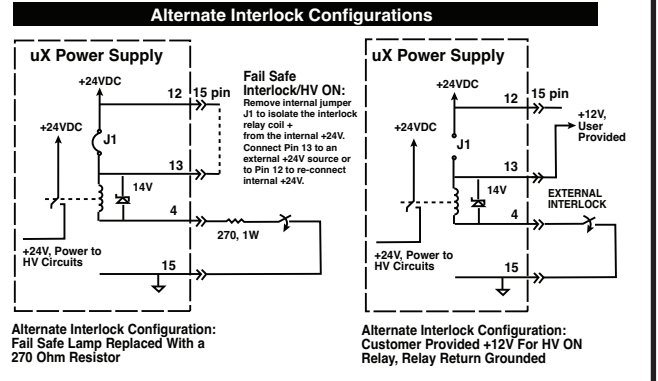
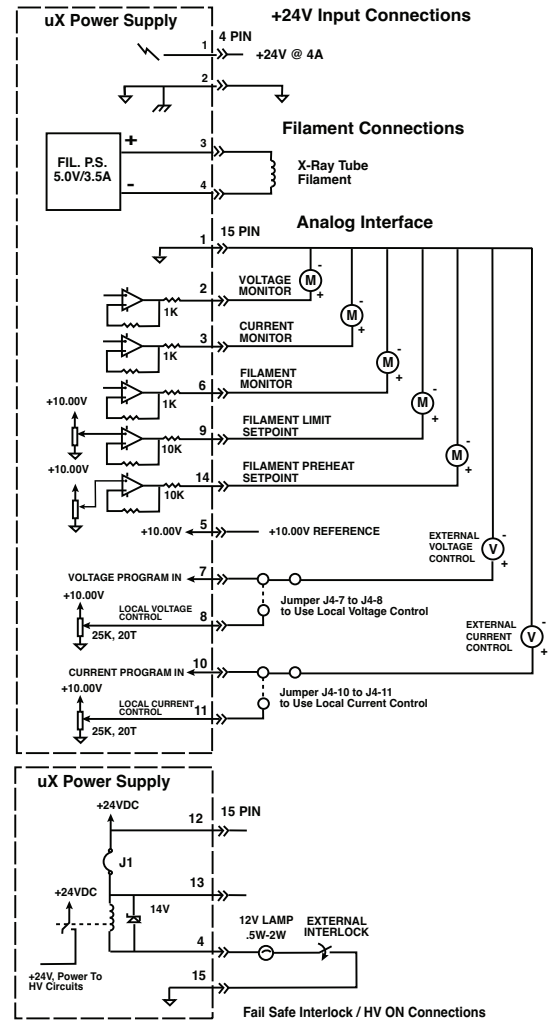
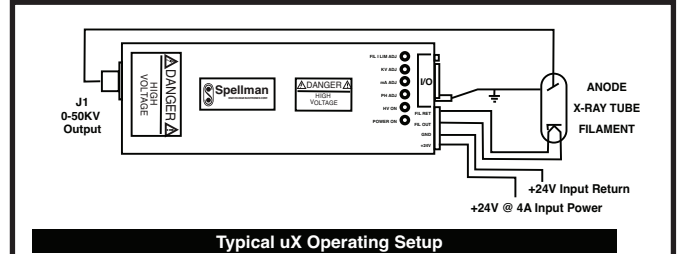
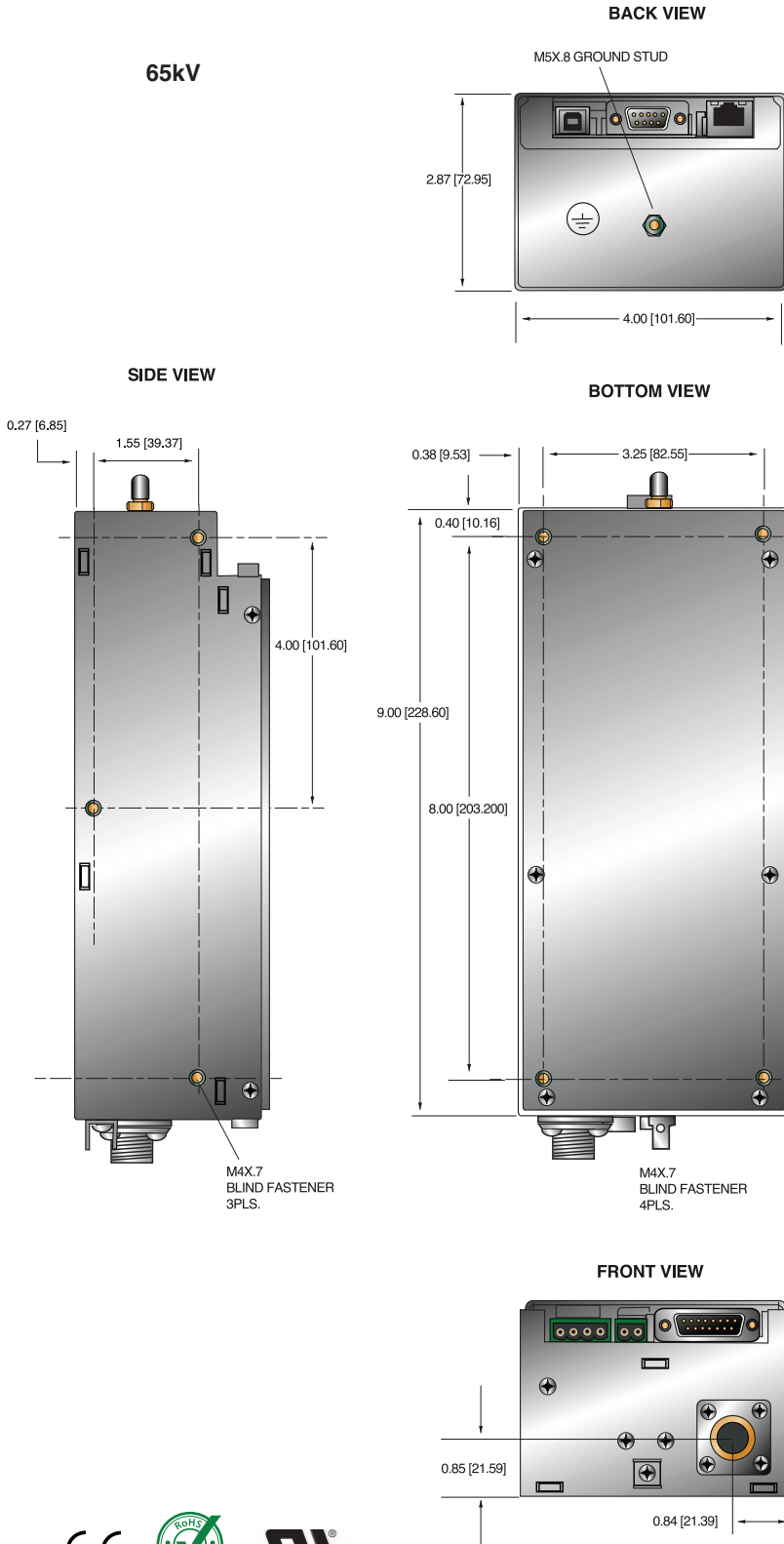



Unit shown has SIC option installed



- **50kV at 2mA, 50 or 75 Watt Max**
- **65kV at 2mA, 65 Watt Max**
- **Floating Integrated Filament Supply**
- **Arc & Short Circuit Protection**
- **Voltage & Current Programming**
- **Local and Remote Emission Control**
- **Safety Interlock**
- **Optional Digital Interface**

www.spellmanhv.com/manuals/MFX

The MFX Series is the result of Spellman's exceptional high voltage packaging and surface mount fabrication techniques, coupled with its proprietary encapsulation technology producing this ultra compact-sized OEM X-Ray generator module.

The MFX Series is designed to power floating filament X-Ray tubes from various manufacturers. It features a 0 to 50kV (or 0 to 65kV) high voltage output, and up to 2mA of emission current limited to 50, 65 or 75 Watts, operating from a +24Vdc input. The MFX utilizes a closed loop filamentary beam control circuit to provide a highly regulated beam current. The floating ac filament supply operates between 0.3 and 4 amps. Offering tight regulation, high stability and low ripple, the MFX provides users both local and remote analog control to set beam voltage, emission current and filament current limit. An optional USB, RS-232 and Ethernet interface is available.

OPTIONS

- SIC** Standard Interface Controller (Ethernet, USB & RS-232)
- 5VPM** 0 to 5 Volt Programming and Monitor Scaling

SPECIFICATIONS

Input:

+24Vdc $\pm 10\%$, 5.0A maximum for either 50 Watts or 75 Watts.
+24Vdc $\pm 1V$, 5.0A maximum for 65kV/65W units.

Efficiency:

80-85%, typical

Output:

0 to 50kV at 0 to 2mA, limited to a maximum of 50 watts or 75 Watts. 0-65kV at 2mA limited to 65 Watts. Negative output polarity.

Voltage Control:

Local: Internal multi-turn potentiometer to set voltage from 0 to full output voltage.
Remote: 0 to +10Vdc proportional from 0 to full output voltage. Accuracy: $\pm 1\%$. Z_{IN} : 10Mohm.

Emission Control:

Local: Internal potentiometer to set beam current between 0 and full output current.
Remote: 0 to +10Vdc proportional from 0 to full output current. Accuracy : $\pm 1\%$. Z_{IN} : 10Mohm. Filament limit and filament preheat control capability is also provided.

High Frequency AC Filament Supply:

Current: 0-4A, adjustable limit
Voltage: 5.0 volt limit

Voltage Regulation:

Load: 0.01% of output voltage no load to full load.
Line: $\pm 0.01\%$ for $\pm 10\%$ change in input voltage.

Current Regulation:

Load: 0.01% of output current from 0 to rated voltage.
Line: $\pm 0.01\%$ for $\pm 10\%$ change in input voltage.

Ripple:

0.1% p-p of maximum rated output voltage, 50kV units (50/75W)
0.1% rms maximum rated output voltage, 65kV units (65W)

Environmental:

Operational: 0°C to +50°C
Storage: -40°C to +85°C
Humidity: 0% to 90%, non-condensing

Temperature Coefficient:

0.01% per °C, voltage and current.

Stability:

0.05% per 8 hours after 1/2 hour warm-up.

Voltage and Current Monitors:

0 to +10Vdc proportional from 0 to rated output. Accuracy $\pm 1\%$.

Dimensions:

50kV Unit: 7.00"H x 2.87"W x 8"D
(177.80mm x 72.90mm x 203.25mm)
65kV Unit: 7.00"H x 2.87"W x 9"D
(177.80mm x 72.90mm x 228.65mm)
SIC Option: 7.75"H x 2.87"W x 8"D/9"D
(196.85mm x 72.90mm x 203.25mm/228.65mm)

Weight:

7.0 lbs. (3.2kg)

Regulatory Approvals:

RoHS compliant.

J2 POWER INPUT CONNECTOR

PIN	SIGNAL	PARAMETER
1	+24V Input	+24 volts @ 5A, max.
2	24V Return (Gnd.)	Power Ground

J4 ANALOG INTERFACE CONNECTOR MALE 15 PIN MINI "D"

PIN	SIGNAL	PARAMETER
1	Monitor Return	Signal Ground
2	Voltage Monitor	0-10 volts = 0 to full scale, Zout=1KΩ
3	Current Monitor	0-10 volts = 0 to full scale, Zout=1KΩ
4	Interlock Output	Connect 12V HVON bulb to pin 15 to enable
5	+10 Volt Reference	+10 Volts @ 1mA, maximum
6	Filament Monitor	1 volt = 1 amp, Zout=1KΩ
7	Voltage Program Input	0-10 volts = 0 to full scale, Zin=10MΩ
8	Local Voltage Program*	10 turn pot., screwdriver adjust
9	Filament Limit Setpoint*	1 volt = 1 amp, screwdriver adjust
10	Current Program Input	0-10 volts = 0 to full scale, Zin=10MΩ
11	Local Current Program*	10 turn pot., screwdriver adjust
12	Not used (+24V Out for Interlock)	(Optional Interlock configuration)
13	Not used (Interlock Coil)	(Optional Interlock configuration)
14	Filament Preheat Setpoint*	1 volt = 1 amp, screwdriver adjust
15	Interlock Return	Interlock Ground

*Denotes 10 turn potentiometer located on front panel

J1 CATHODE OUTPUT CLAYMOUNT HV CONNECTOR

PIN	OUTPUT CONNECTION
C (common)	-High Voltage Output
S (small)	-High Voltage Output
L (large)	Filament Output
G (grid)	Filament Output

Note: No high voltage cable is provided

Recommended Cable:

Claymount part number: 11470

Cable assembly, L3 CA11, CA11, 10F, CS=Bare 10 foot, Mini Federal Connectors on both ends, "C" and "S" are both connected to the bare wire

How To Order:

Sample model number:
 50 Watt unit: MFX50N50
 65 Watt unit: MFX65N65
 75 Watt unit: MFX50N75

Options are added to the model number as follows:
 MFX50N75/SIC

DIMENSIONS: in.[mm]

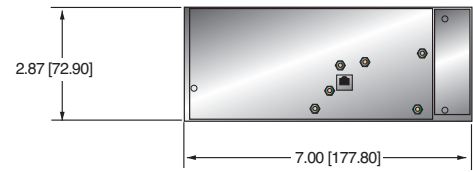
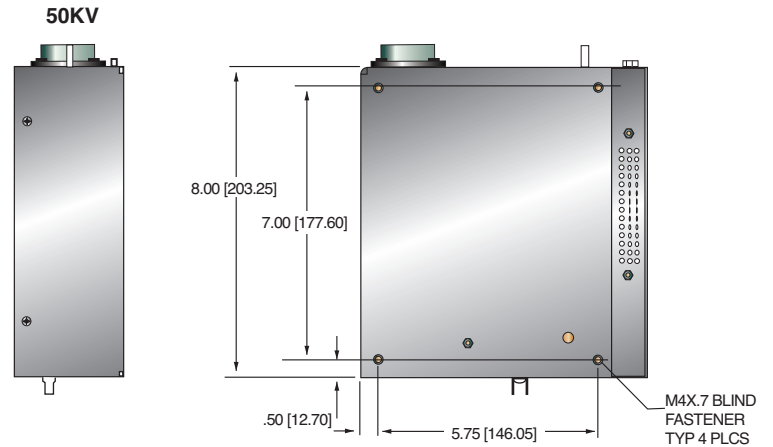

50KV WITH SIC OPTION

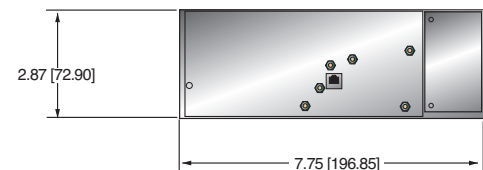
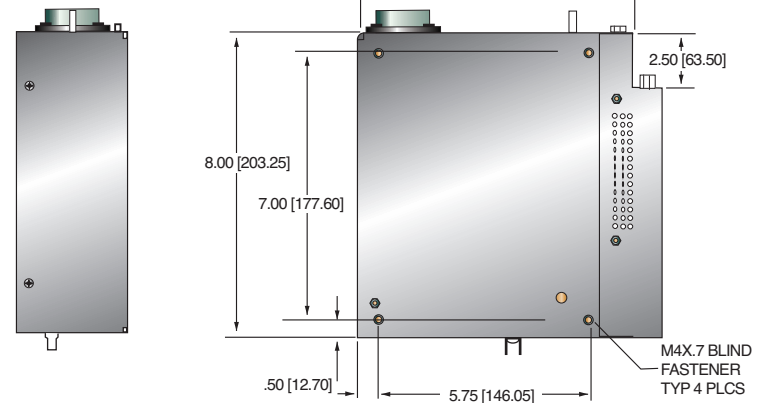

DIMENSIONS: in.[mm]

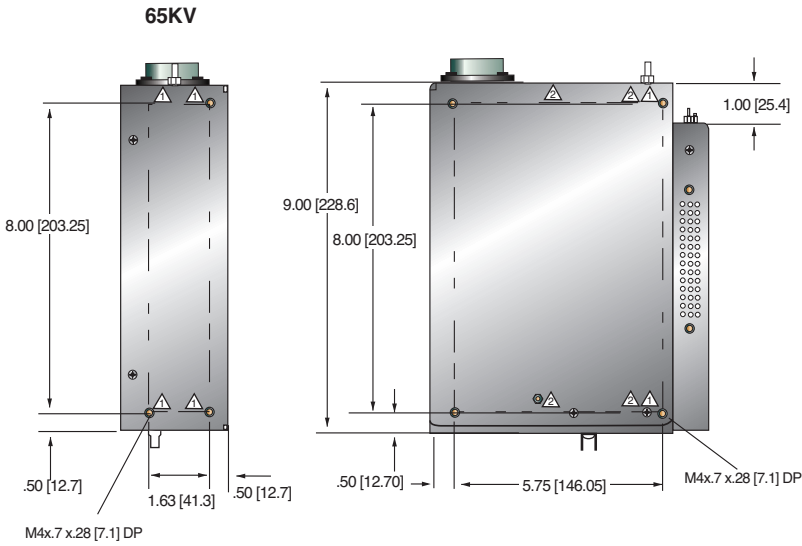

△ = ALTERNATE MOUNTING OPTION
△ = STANDARD MOUNTING OPTION

65KV WITH SIC OPTION

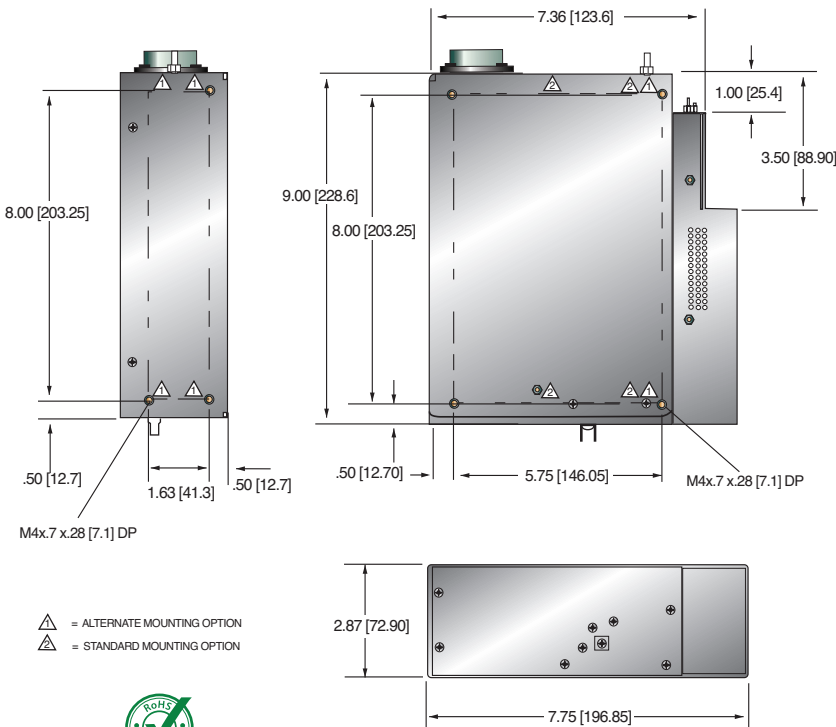

△ = ALTERNATE MOUNTING OPTION
△ = STANDARD MOUNTING OPTION

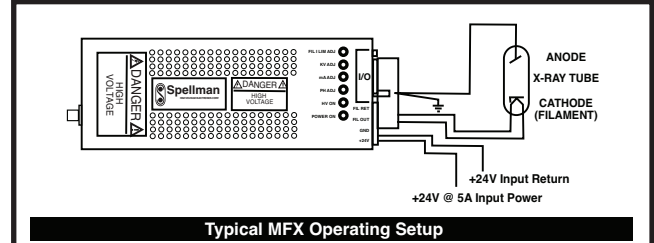

Typical MFX Operating Setup

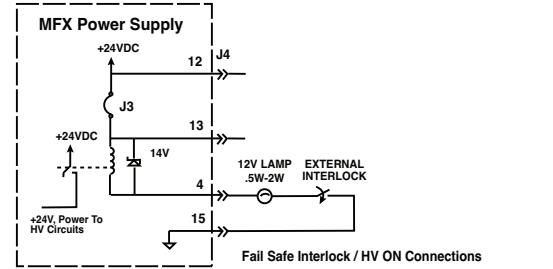
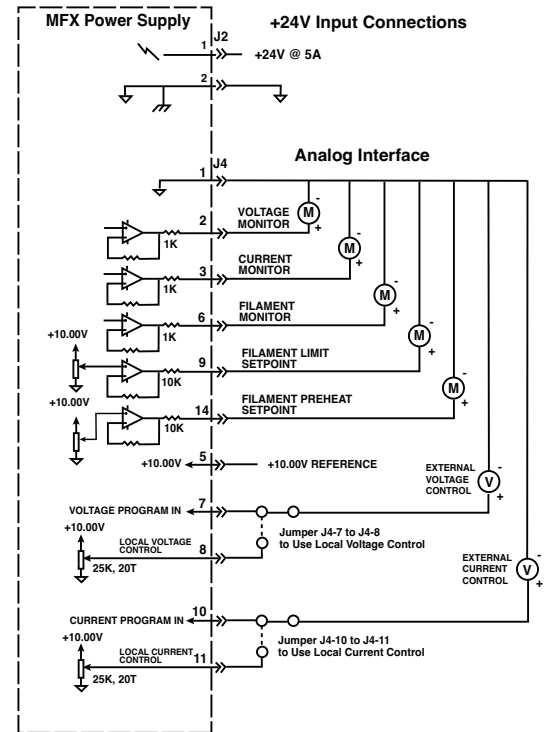

Alternate Interlock Configurations

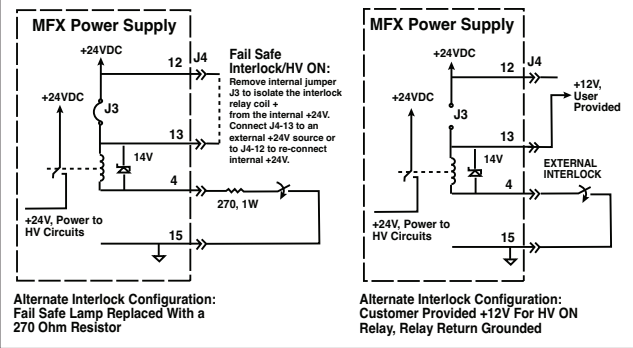



Spellman's XRF Series allow for a wide range of input voltages and supply either 80W, 320W or 640W of output power at up to 160kVdc. These lightweight rack-mountable X-Ray generators house a miniaturized high voltage system in a solid encapsulated, oil-free design. The XRF Series is designed with a power factor corrected input circuit which reduces harmonic emissions and noise normally associated with other high frequency switching power supplies. The XRF Series incorporates an internal floating filament and a closed-loop emission control circuit for precise regulation of emission current. Remote monitoring and control of voltage, current and filament current is also provided.

TYPICAL APPLICATIONS

X-Ray Inspection, Non-Destructive Testing

OPTIONS

DF Dual Filament	AT Arc Trip
GS Grid Supply	IO Instant ON
SL Slides	SS(X) Non Standard Slow Start

SPECIFICATIONS

Input Voltage:

80W: 90-125Vac at 48-62Hz @ 1.9A
 180-264Vac at 48-62Hz @ 0.9A
 320W: 180-264Vac at 48-62Hz @ 3.5A
 640W: 180-264Vac at 48-62Hz @ 7A

Power Factor:

0.9 or better.

High Voltage Supply:

Output Voltage:

0-160kV, negative polarity.

Output Current:

80W: 0.5mA max.
 320W: 2.0mA at 160kV
 640W: 4.0mA

Output Voltage Stability:

Within 0.1% of set value after warm-up period at full load.

Output Voltage Ripple:

80W & 320W: <0.1%, or 160V p-p for high freq. and line freq. at full load.
 640W: 0.03% rms <1kHz, 0.75% rms above 1kHz.

Beam Current Stability

80W: Within 0.1% of set value after 1/2 hour warm-up at constant output setting of 30-160kV and line voltage of 90-125 & 180-264Vac.

320W & 640W:

Same as 80W except line voltage of 180-264Vac.

- **160kV Output Voltage**
- **Rack-Mountable**
- **Floating Filament**
- **Internal Grid Power Supply (80W Model)**
- **Power Factor Correction**
- **Closed-loop Emission Control**
- **OEM Customization Available**

www.spellmanhv.com/manuals/XRF

Filament Supply:

Constant current DC filament supply with closed-loop current feedback.

Filament Voltage:

7V rms (high frequency) max.

Filament Current:

5A max., adjustable 0-5.0A by external Filament Limit Programming input.

Floating Grid Power Supply:

Grid Supply: The grid supply controls tube beam current in a closed-loop regulation design.

Grid Voltage: 0 to 1200Vdc.

Grid Voltage Ripple: Less than 1.0V rms at any frequency.

Grid Supply Response: Less than 0.5mA in less than 10ms.

Control and Monitoring:

Analog Control Inputs: Three inputs have internal load resistance greater than 330kohms.

Voltage Programming:

80W, 320W & 640W:
 0 to +10Vdc, where 10.0Vdc = 160kV output.

Beam Tube Current Control:

80W: 0 to +10Vdc, where 10.0Vdc = 0.5mA tube current.
 320W: 0 to +10Vdc, where 10.0Vdc = 2.0mA tube current.
 640W: 0 to +10Vdc, where 10.0Vdc = 4.0mA tube current.

Filament Current Control:

0 to +10Vdc, where 5.0Vdc = 5.0A filament current.

Analog Monitor Outputs: (See tables for details)

Digital Control Inputs: (See tables for details)

Digital Outputs: (See tables for details)

Connections:

Output Connector:

R24 (see owners manual for details)

Input Power Connector:

5-pin male MS-type, Amphenol P/N 97-3102A-18-20P

Control Connector:

25-pin "D" connector, male, chassis-mounted.

Environmental:

0 to +50°C at 10-95% RH, non-condensing.
 Forced convection cooling.

Dimensions:

7"H x 19"W x 22"D (17.8cm x 48.3cm x 55.9cm).

Regulatory Approvals:

Compliant to EEC EMC Directive. Compliant to EEC Low Voltage Directive. RoHS Compliant.

Electronic Component (Power Source)

XRF series is intended for installation as a component of a system.

It is designed to meet CE standards, with conditions of acceptance often being: customer provided enclosure mounting, EMC filtering, and appropriate protection, and isolation devices. The XRF series is not intended to be operated by end users as a stand-alone device. The XRF series power supply can only be fully assessed when installed within a system, and as a component part within that system.

160kV XRF SELECTION TABLE

OUTPUT VOLTAGE kV	OUTPUT CURRENT mA	OUTPUT POWER W	MODEL NUMBER XRFxxx
160	0.5	80	XRF160N80
160	2.0	320	XRF160N320
160	4.0	640	XRF160N640

J2 AC INPUT CONNECTOR WIRING

5 Pin MS Type	7 Pin UTG Type	CONNECTION
A	1	Auxiliary (Logic) Line
B	2	Auxiliary (Logic) Neutral
C	3	Ground
D	4	Main (Inverter) Line
E	5	Main (Inverter) Neutral

JB1 160kV XRF 80W, 320W, 640W 25 PIN

PIN	SIGNAL	SIGNAL PARAMETERS
1	Filament Limit	0-5V = 0-5A Filament Limit
2	High Voltage on Control	+12VDC IN = HV ON
3	N/C	
4	N/C	
5	High Voltage On Status	Low = HV ON
6	A-Ground	Ground
7	kV Monitor	0-10V = 0-160kV
8	Interlock Control	+12VDC IN = Interlock Closed
9	N/C	
10	mA Demand	0-10V = 0-100% Rated Output
11	N/C	
12	N/C	
13	D-Ground	Ground
14	Fil. Monitor	0-5V = 0-5A
15	N/C	
16	N/C	
17	N/C	
18	N/C	
19	mA Monitor	0-10V = 0-100% Rated Output
20	N/C	
21	+12VDC Out	
22	kV Demand	0-10V = 0-160kV
23	Grid Inhibit/Fil. Select	Low = Grid Inhibit
24	N/C	
25	Chassis Gnd (I/O Shield)	Chassis Gnd.

160kV XRF 80W, 320W, 640W TERMINAL BLOCK 10 PIN

PIN	SIGNAL	SIGNAL PARAMETERS
1	Interlock	Jumper to TB1-2 to close interlock
2	Interlock Return	
3	kV Monitor	0-10V=0-160kV
4	mA Monitor	0-10V = 0-100% Rated Output
5	Filament Monitor	0-5V=0-5A
6	N/C	
7	HV ON Indicator	+15V = HV ON
8	Voltage Mode Indicator	Low = Voltage Mode.
9	Current Mode Indicator	Low = Current Mode.
10	GND	Ground

DIMENSIONS: in.[mm]

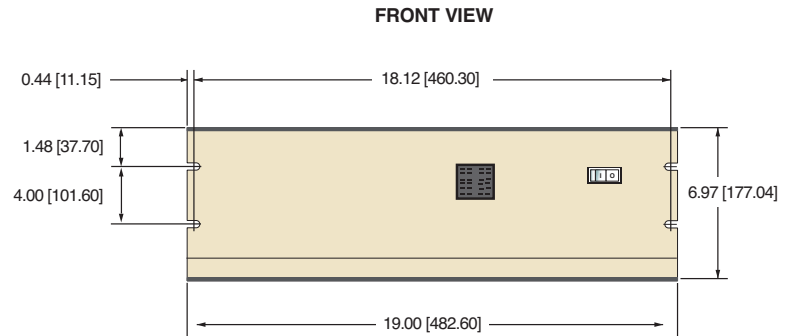

TOP VIEW



BACK VIEW

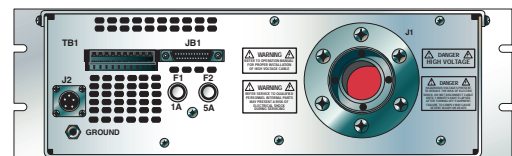



80kV unit shown



Ask about our X-Ray subsystem capabilities

- **50kV, 65kV and 80kV Output Voltage**
- **100W Output Power**
- **Adjustable Ground Isolated Filament Supply**
- **Oversoltage & Short Circuit Protection**
- **Voltage & Current Programming**
- **Local and Remote Emission Control**
- **Safety Interlock**
- **RS-232, Ethernet, & USB Standard**
- **Redundant HV Monitor Signal**

www.spellmanhv.com/manuals/uXHP

The uXHP Series is the result of Spellman's exceptional high voltage packaging and surface mount fabrication techniques coupled with proprietary encapsulation technology producing this ultra-compact X-Ray generator module. The uXHP powers grounded cathode X-Ray tubes from a variety of well-known manufacturers, featuring a 0 to 50kV/65kV/80kV high voltage output @ 5mA limited to 100W. The uXHP uses closed loop filament control circuitry providing highly regulated beam current. The low noise dc filament supply operates between 0.3 and 3.5A. Offering tight regulation, high stability and low ripple, the uXHP provides users local and remote analog control to set beam voltage, emission current and filament current limit. USB, RS-232 and Ethernet interface is standard.

TYPICAL APPLICATIONS

Powering grounded cathode X-Ray tubes from Varian, Kevex, Oxford, RTW, Superior and Trufocus.

SPECIFICATIONS

Input:

+24Vdc ±1V; 7.75A maximum

Efficiency:

75%, typical

Output:

See model selection table on page 2

Voltage Control:

- Local: Internal multi-turn potentiometer to set voltage from 0 to full output voltage.
- Remote: 0 to 10Vdc = 0 to 100% rated output voltage. Accuracy: ±1%. $Z_{IN} = 10\text{Mohm}$.

Emission Control:

- Local: Internal potentiometer to set beam current from 0 to full output current.
- Remote: 0 to 10Vdc = 0 to 100% rated output current. Accuracy: ±1%. $Z_{IN} = 10\text{Mohm}$. Filament limit and filament preheat control capability is also provided.

Voltage and Current Monitors:

0 to 10Vdc = 0 to 100% rated output
Accuracy: ±1%. $Z_{OUT} = 1\text{kohm}$

Redundant Voltage Monitor:

A redundant high voltage feedback divider where 0 to 10Vdc = 0 to 100% rated output is monitored via firmware. The analog monitor signal can be provided by special order.

Temperature Coefficient:

0.01% per °C, voltage and current.

Stability:

0.05% per 8 hours after 1/2 hour warm-up.

Digital Interface:

RS-232, Ethernet and USB is standard

DC Filament Supply:

Ground isolated filament power supply allows actual tube current feedback signal for monitoring accurate low X-Ray tube current performance.

Current: 0-3.5A, adjustable limit

Voltage: 5.0V, maximum compliance

Environmental:

Operational: 0° C to +50° C

Storage: -40° C to +85° C

Humidity: 0% to 90%, non-condensing

Dimensions:

50/65kV Unit: 7.00"H x 3.07"W x 9.00"D
(177.80mm x 78.00mm x 228.60mm)

80kV Unit: 7.00"H x 3.07"W x 10.50"D
(177.80mm x 78.00mm x 266.70mm)

Weight:

50/65kV Unit: 8.5 lbs. (3.85kg)

80kV Unit: 10.0 lbs. (4.53kg)

Cooling:

User provided forced air cooling is required

Regulatory Approvals:

Compliant to EEC EMC Directive. Compliant to EEC Low Voltage Directive. UL/CUL recognized, File E227588. RoHS Compliant.

uXHP MODEL SELECTION TABLE

OUTPUT VOLTAGE	OUTPUT CURRENT	OUTPUT POWER	MODEL NUMBER
0-50kV	0-5mA	100W	uXHP50P100
0-65kV	0-5mA	100W	uXHP65P100
0-80kV	0-5mA	100W	uXHP80P100

CONTROL POWER/FILAMENT CONNECTOR 4 PIN PHOENIX CONTACT

PIN	SIGNAL	PARAMETER
1	+24V Control Power	+24V @ 1A max
2	+24V Control Power Return	Power Ground
3	Filament Output	0.3A to 3.5A @ 5V, max
4	Filament Return	Filament Return

Note: The filament return wire cannot be grounded as this would short circuit the tube return current monitoring to the uXHP. If grounding of the filament is required, please consult the factory.

HIGH VOLTAGE POWER INPUT CONNECTOR 2 PIN PHOENIX CONTACT

PIN	SIGNAL	PARAMETER
1	+24V High Voltage Power Input	+24V @ 7.75A max
2	+24V High Voltage Power Return	Power Ground

ANALOG INTERFACE CONNECTOR MALE 15 PIN MINI "D"

PIN	SIGNAL	PARAMETER
1	Monitor Return	Signal Ground
2	Voltage Monitor	0-10V = 0 to full scale, Zout=1KΩ
3	Current Monitor	0-10V = 0 to full scale, Zout=1KΩ
4	Interlock Output	Connect 12V HV ON bulb to pin 15 to enable
5	+10V Reference	+10V at 1mA, maximum
6	Filament Monitor	1V = 1A, Zout=1KΩ
7	Voltage Program Input	0-10V = 0 to full scale, Zin=10MΩ
8	Local Voltage Program*	0-10V, screwdriver adjust
9	Filament Limit Setpoint*	1V = 1A, screwdriver adjust
10	Current Program Input	0-10V = 0 to full scale, Zin=10MΩ
11	Local Current Program*	10 turn pot, screwdriver adjust
12	Not used (+24V Out for Interlock)	(Optional Interlock configuration)
13	Not used (Interlock Coil)	(Optional Interlock configuration)
14	Filament Preheat Setpoint*	1V = 1A, screwdriver adjust
15	Interlock Return	Interlock Ground

*Denotes 10 turn potentiometer accessible through holes in cover

USB DIGITAL INTERFACE — 4 PIN USB "B" CONNECTOR

PIN	SIGNAL	PARAMETER
1	VBUS	+5Vdc
2	D-	Data -
3	D+	Data +
4	GND	Ground

HIGH VOLTAGE OUTPUT CONNECTOR

Spellman drywell type detachable connector.

50/65kV: A one meter (39.4") long polyethylene mating high voltage cable with banana plug termination is provided.

80kV: A one meter (39.4") long polyethylene mating high voltage cable with corona ball termination is provided.

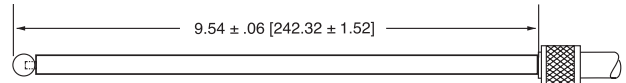

HV Cable Options:

5302: (50kV unit only)
A one meter (39.4") long Mammoflex mating high voltage cable is provided, SHV p/n 201946-007

2001: (50kV with XCC option and 65kV units only)
A one meter (39.4") long Mammoflex mating high voltage cable is provided, compatible with the XCC Option SHV p/n 201946-002

ETHERNET DIGITAL INTERFACE — 8 PIN RJ45 CONNECTOR

PIN	SIGNAL	PARAMETER
1	TX+	Transmit Data +
2	TX-	Transmit Data -
3	RX+	Receive Data +
4	NC	No Connection
5	NC	No Connection
6	RX-	Receive Data -
7	NC	No Connection
8	NC	No Connection

RS-232 DIGITAL INTERFACE — 9 PIN FEMALE D CONNECTOR

PIN	SIGNAL	PARAMETER
1	NC	No Connection
2	TX out	Transmit Data
3	RX in	Receive Data
4	NC	No Connection
5	SGND	Ground
6	NC	No Connection
7	NC	No Connection
8	Voltage Monitor 2	0-10V = 0 to full scale, Zout = 1KΩ
9	Power Supply OK	+15V = OK, 0V = Fault, Sink/Source 3mA max

How To Order:

Sample model number:
50kV unit: uXHP50P100
65kV unit: uXHP65P100
80kV unit: uXHP80P100

Ask about our X-Ray subsystem capabilities

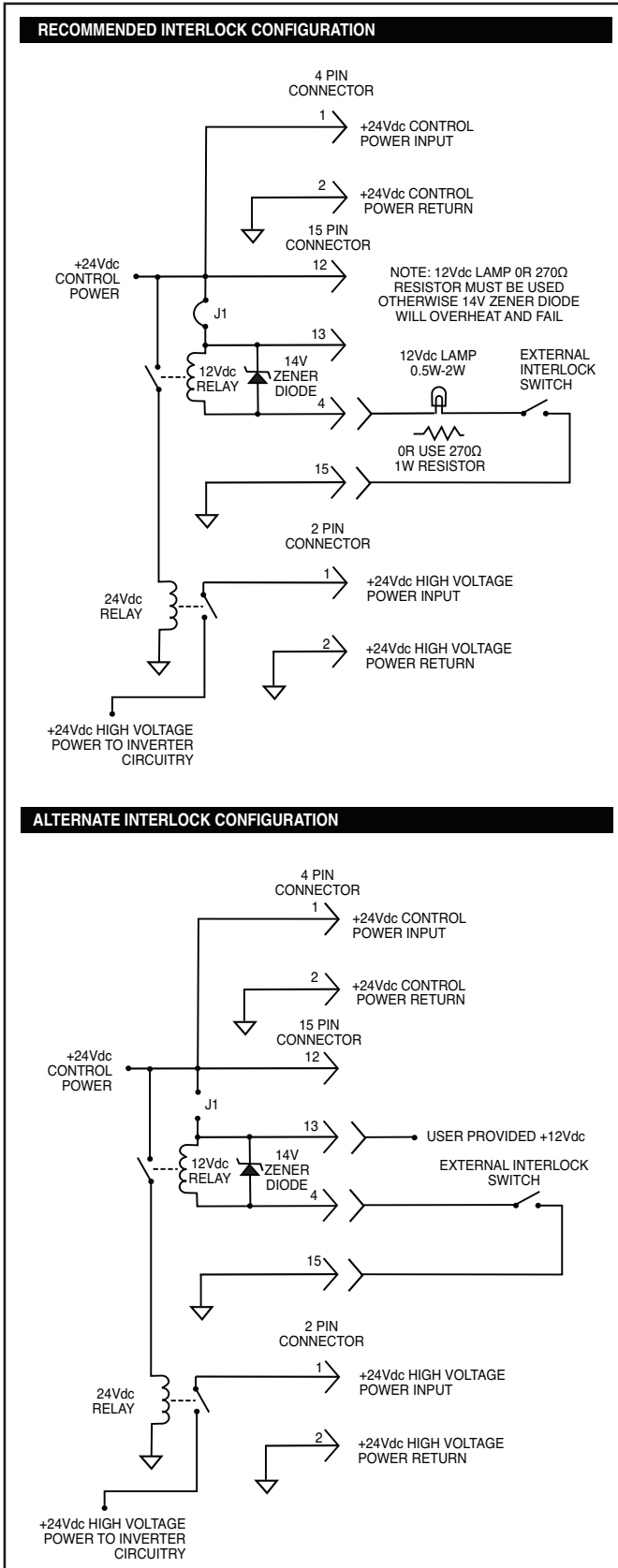

Digital Interface

The uXHP features a standard USB, RS-232 and Ethernet digital interface. Utilizing these standard digital interfaces can dramatically simplify power supply interfacing requirements saving the user both time and money, while enhancing functionality and overall capability. Spellman provides a GUI with the uXHP that allows the customer to both customize operational features of the uXHP while also providing basic power supply operational features. Details of the uXHP's digital interface capability are described in detail in the uXHP manual.



Closeup showing digital interface connectors

Filament Status Screen



Main Control Screen



Varian VF-80J X-Ray Tube

The uXHP was specifically designed in cooperation with Varian to power their new VF-80J X-Ray tube. This joint effort resulted in the creation of both the VF-80J X-Ray tube and the uXHP X-Ray generator. The Varian VF-80J tube is uniquely rated to run at up to 80kV @ 100 watts, 4mA maximum. The uXHP was explicitly designed to operate at up to 80kV



and provide 100 watts down to 25kV, so customers could make full use of the capabilities of the VF-80J X-Ray tube. Varian and Spellman, working together to push the boundaries of X-Ray technology.



DIMENSIONS: in.[mm]

50kV, 50kV/XCC and 65kV

BACK VIEW

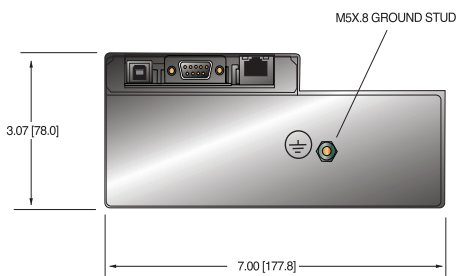

BOTTOM VIEW

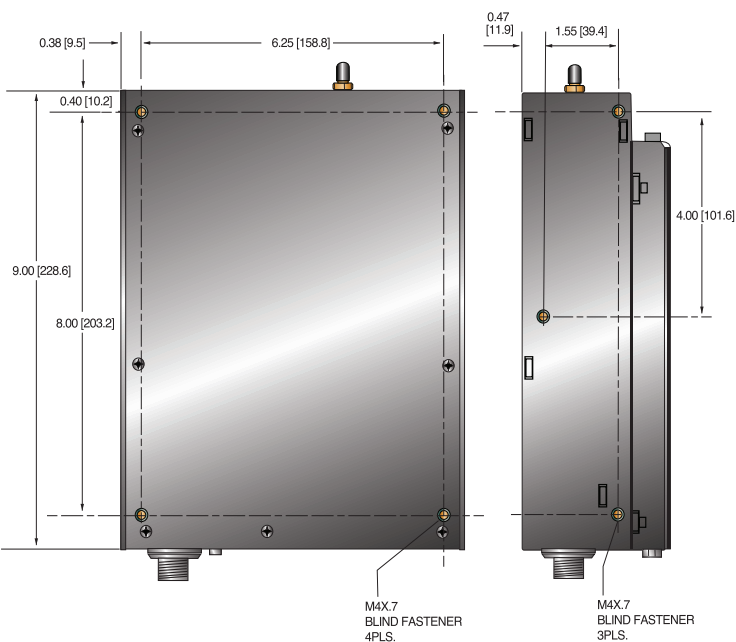

SIDE VIEW

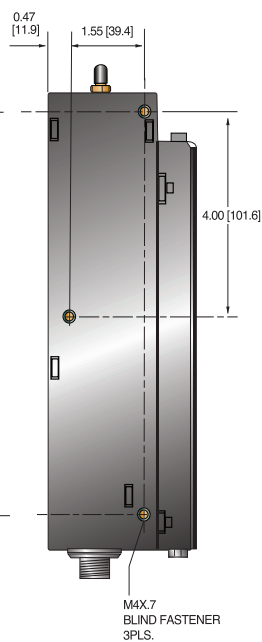

FRONT VIEW

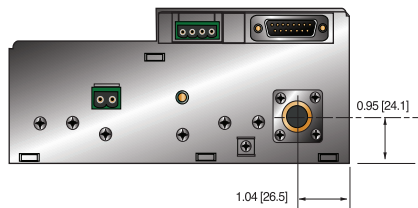

80kV

BACK VIEW

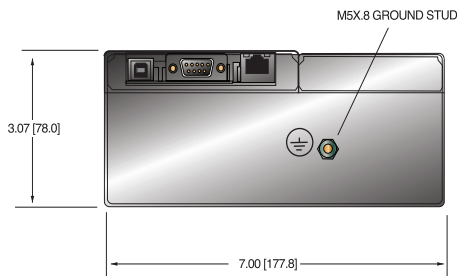

BOTTOM VIEW

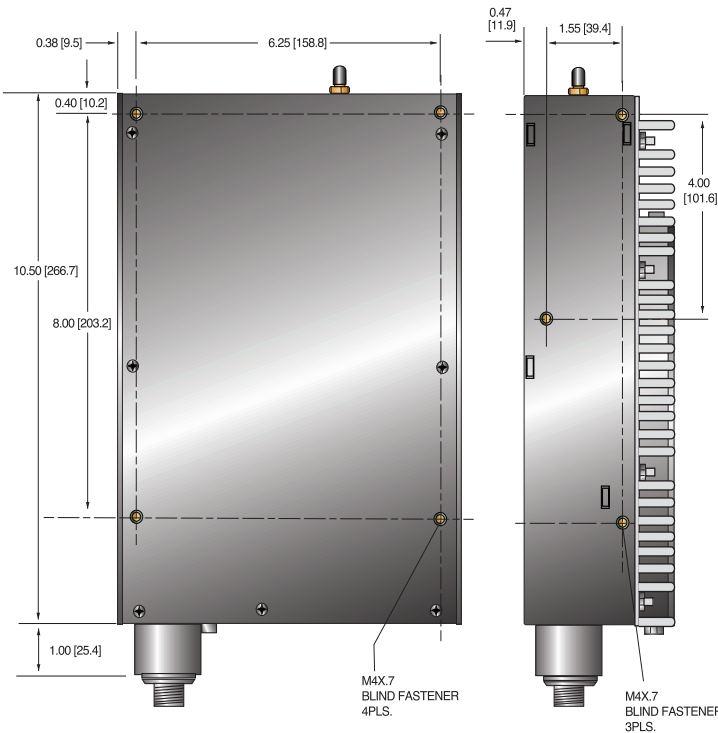

SIDE VIEW

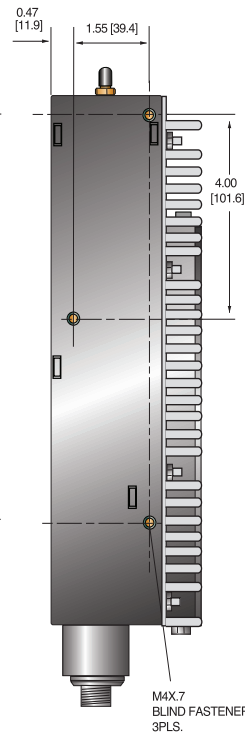

FRONT VIEW

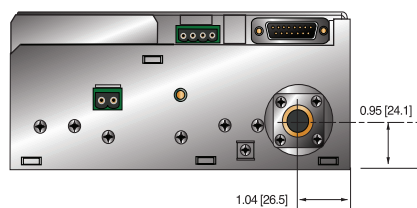



- **Compact & Lightweight**
- **Models from 20kV-160kV, 300W, 600W and 1200W**
- **Universal Input, Power Factor Corrected**
- **Hot Anode or Hot Cathode X-Ray Tube Capable**
- **Standard Digital Interfaces: USB, Ethernet and RS-232**
- **CE Compliant, UL Recognized and RoHS Compliant**
- **User Programmable Ramping and Arc Detect Feature**

www.spellmanhv.com/manuals/DXM

Spellman's new DXM Series of X-Ray generator modules are designed for OEM applications up to 160kV at 1200 watts. Its universal input, small package size and choice of three standard digital interfaces simplifies integrating the DXM into your X-Ray analysis system. Models are available to operate either floating filament (negative HV polarity) or ground referenced filament (positive HV polarity), X-Ray tube designs. DSP based emission control circuitry provides excellent regulation of emission current, along with outstanding stability performance.

TYPICAL APPLICATIONS

- | | |
|---------------------|--------------------|
| Plastics Sorting | Mineral Analysis |
| Crystal Inspection | X-Ray Fluorescence |
| Plating Measurement | X-Ray Diffraction |
| Diamond Inspection | |

SPECIFICATIONS

Input Voltage:

- Power factor corrected input
90-264Vac: 47-63Hz @ 4.6A for 300 watt units
180-264Vac: 47-63Hz @ 4.3A for 600 watt units
47-63Hz @ 8.2A for 1200 watt units

Output Voltage:

- 8 models—20kV, 30kV, 40kV, 50kV, 60kV, 70kV, 75kV and 160kV

Output Polarity:

- Negative- for floating filament X-Ray tubes
Positive- for ground referenced filament X-Ray tubes

Power:

- 3 power ranges available—300 watts, 600 watts and 1200 watts
Other power levels available on special order.

Output Voltage Regulation:

- ≤0.01% of rated output voltage over specified input voltage range
≤0.01% of rated output voltage for a full load change

Emission Current Regulation:

- ≤0.01% of rated output current over specified input voltage range
≤0.01% of rated output current for a change from 30% to 100% of rated output voltage
Filament is disabled when kV is <30% of full scale output

Ripple:

- ≤1%rms at >20kHz, 0.1%rms below 20kHz

Stability:

- ≤25ppm/hr after a 2 hour warm up

Temperature Coefficient:

- ≤50ppm per degree C

Environmental:

- Temperature Range:
Operating: 0°C to 40°C
Storage: -40°C to 85°C

Humidity:

- 20% to 85% RH, non-condensing.

Filament Configuration:

- Closed loop emission control regulates filament setting to provide desired X-Ray tube emission current. Two types are available: Floating Filament (ac output referenced to negative output voltage) and Ground Referenced Filament (dc output referenced to ground).

Output:

- 0-5 amps at a compliance of 10 volts, maximum.
The filament loop is disabled when the kV output is less than 30% of full scale output to protect the X-Ray tube.
Standard filament Preheat adjustable 0-2.5 amps.
Other filament levels available on special order.

Control Interface

Local Interface:

- Potentiometers are provided to adjust filament limit and preheat levels

Remote Interface:

USB, Ethernet and RS-232 are standard. All digital monitors have an accuracy specification of 2%

Control Software:

A Windows graphical user interface example is provided. Built-in diagnostics can be performed over Ethernet via a Java applet and any standard web browser

High Voltage Enable:

A hardware based, dry contact closure will enable the power supply into the high voltage on mode

Monitor Signals:

Voltage and current monitor signals are scaled 0-10Vdc equals 0-100% of full scale, accuracy is 1%

Dimensions:

- 300/600 Watts: 4.75" H X 6" W X 12" D
(120.65mm x 152.4mm x 304.8mm)
1200 Watts: 4.75" H X 12" W X 12" D
(120.65mm x 304.8mm x 304.8mm)
160kV: 10.5" H X 19" W X 21.5" D
(266.7mm x 482.6mm x 546.1mm)

Weight:

- 300/600 Watts: 14 pounds (6.35kg)
1200 Watts: 26 pounds (11.8kg)
160kV: 142 pounds (66.4kg)

Cooling:

Forced air

Input Line Connector:

IEC320 with EMI filter

Output Connector:

Depends upon polarity selected. See table and drawing.
Other connectors and pinouts available on special order.

Regulatory Approvals:

Compliant to EEC EMC Directive. Compliant to EEC Low Voltage Directive. UL/CUL recognized, File E227588. RoHS Compliant.

DXM SELECTION TABLE — 300W, 600W, 1200W

300 Watt			600 Watt		1200 Watt	
kV	mA	Model	mA	Model	mA	Model
20	15	DXM20*300	30	DXM20*600	60	DXM20*1200
30	10	DXM30*300	20	DXM30*600	40	DXM30*1200
40	7.5	DXM40*300	15	DXM40*600	30	DXM40*1200
50	6	DXM50*300	12	DXM50*600	24	DXM50*1200
60	5	DXM60*300	10	DXM60*600	20	DXM60*1200
70	4.28	DXM70*300	8.56	DXM70*600	17.12	DXM70*1200
75	4	DXM75*300	8	DXM75*600	16	DXM75*1200
160					7.5	DXM160N1200

*Specify "P" for positive polarity or "N" for negative polarity

FILAMENT TERMINAL BLOCK — TB1 TWO POSITION TERMINAL BLOCK

POSITION	SIGNAL	SIGNAL PARAMETERS
1	Filament Output	0-5 amps, 10Vdc Maximum
2	Filament Return	Filament Return

For positive polarity/ground referenced filament units

DXM ANALOG INTERFACE — J2 15 PIN MALE D CONNECTOR

PIN	SIGNAL	SIGNAL PARAMETERS
1	Power Supply Fault	Open Collector, 35V @ 10mA Maximum
2	Current Program In	0 to 10V=0 to 100% Rated Output, Zin=10MΩ
3	Voltage Program In	0 to 10V=0 to 100% Rated Output, Zin=10MΩ
4	Filament Limit Input	0 to 10V=0 to 100% Rated Output, Zin=10MΩ
5	Local Filament Limit	Multi-turn front panel potentiometer
6	Filament Preheat Input	0 to 10V=0 to 100% Rated Output, Zin=10MΩ
7	Local Filament Preheat	Multi-turn front panel potentiometer
8	Voltage Monitor	0 to 10V=0 to 100% Rated Output, Zout =4.99k, 1%
9	Signal Ground	Ground
10	Current Monitor	0 to 10V=0 to 100% Rated Output, Zout =4.99k, 1%
11	X-Ray Enable Input	Connect to Pin 12 to HV Enable Supply
12	X-Ray Enable Output	+15V @ Open, ≤15mA @ Closed
13	Filament Monitor	1 Volt=1 Amp, Zout=10kΩ
14	X-Ray On Output Signal	Open Collector, 35V @10mA Maximum
15	Spare	N/C

RS-232 DIGITAL INTERFACE — J3 9 PIN FEMALE D CONNECTOR

PIN	SIGNAL	SIGNAL PARAMETERS
1	N/C	No Connection
2	TX out	Transmit Data
3	RX in	Receive Data
4	N/C	No Connection
5	SGND	Ground
6	N/C	No Connection
7	N/C	No Connection
8	N/C	No Connection
9	N/C	No Connection

USB DIGITAL INTERFACE — J4 4 PIN USB "B" CONNECTOR

PIN	SIGNAL	SIGNAL PARAMETERS
1	VBUS	+5 Vdc
2	D-	Data -
3	D+	Data +
4	GND	Ground

ETHERNET DIGITAL INTERFACE — J5 8 PIN RJ45 CONNECTOR

PIN	SIGNAL	SIGNAL PARAMETERS
1	TX+	Transmit Data +
2	TX-	Transmit Data -
3	RX+	Receive Data +
4	N/C	No Connection
5	N/C	No Connection
6	RX-	Receive Data -
7	N/C	No Connection
8	N/C	No Connection

R24 HV CONNECTOR PINOUT J6 CATHODE OUTPUT (160kV)

PIN	OUTPUT CONNECTION
C (common)	High Voltage Output
S (small)	Filament Output
L (large)	Filament Output

HIGH VOLTAGE OUTPUT CONNECTOR — J6 FLOATING FILAMENT

20kV-75kV Negative Polarity:
Claymont Mini Federal standard X-Ray connector
160kV Negative Polarity:
R24 (cable not provided)

HIGH VOLTAGE OUTPUT CONNECTOR — J6:GROUND FILAMENT

Positive Polarity: Spellman High Voltage Delrin Drywell connector.
4 foot (1.21m) long high voltage cable provided

For positive polarity units a ground referenced filament output is provided on a two position terminal TB1. See table

CLAYMOUNT HV CONNECTOR

PIN	OUTPUT CONNECTION
C (common)	High Voltage Output
S (small)	High Voltage Output
L (large)	Filament Output
G (grid)	Filament Output

Note: No high voltage cable is provided

Recommended Cable: Claymont part number: 12096
Cable assembly, L3 CA11, CA11, 10F, CS=Bare 10 foot, Mini Federal Connectors on both ends, "C" and "S" are both connected to the bare shield wire

DIMENSIONS: in.[mm]

300/600 Watt

Negative Polarity - Floating Filament

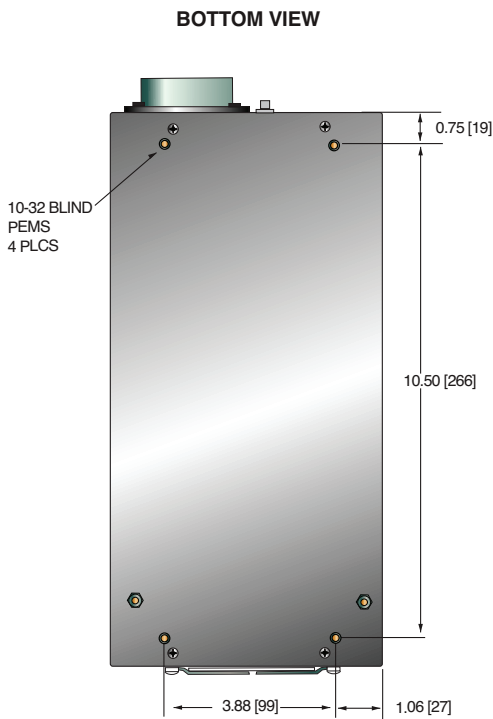

Positive Polarity - Ground Filament

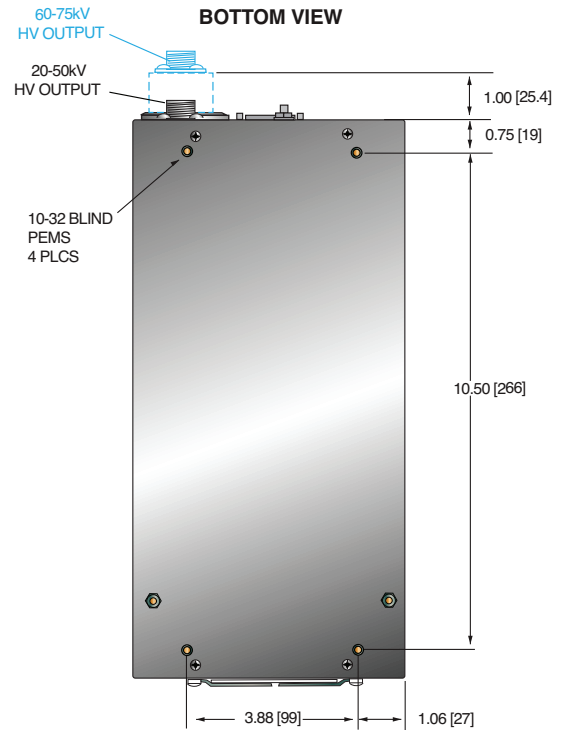

FRONT VIEW

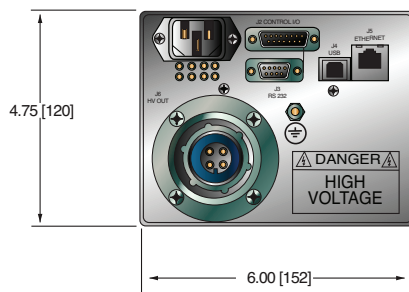

FRONT VIEW

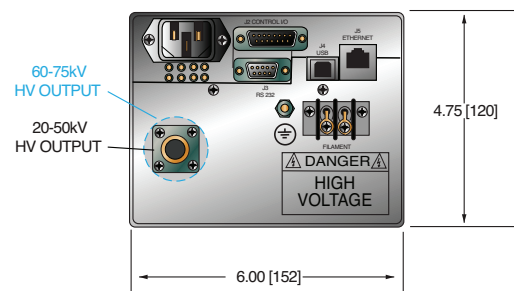

SIDE VIEW

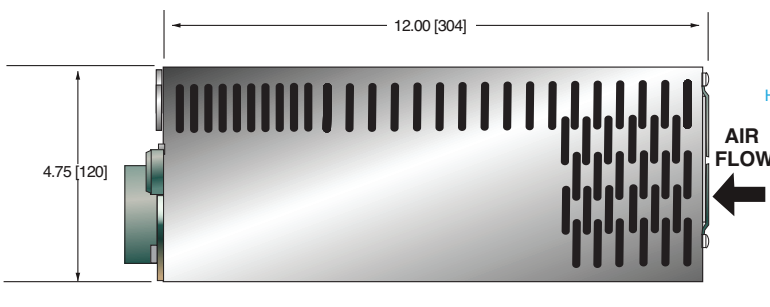

SIDE VIEW

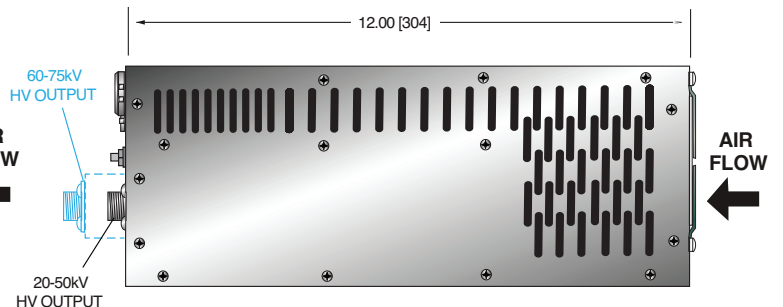

DIMENSIONS: in.[mm]

1200 Watt

Negative Polarity - Floating Filament

BOTTOM VIEW

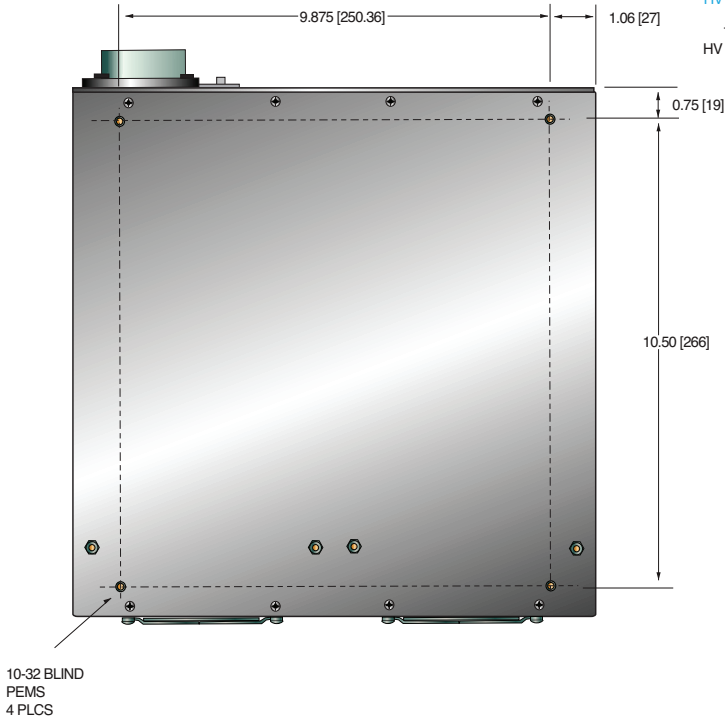

FRONT VIEW

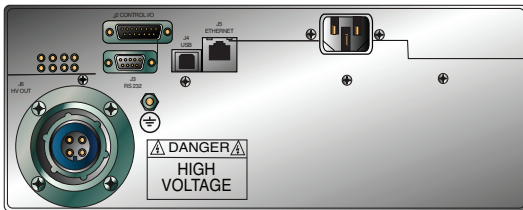

SIDE VIEW

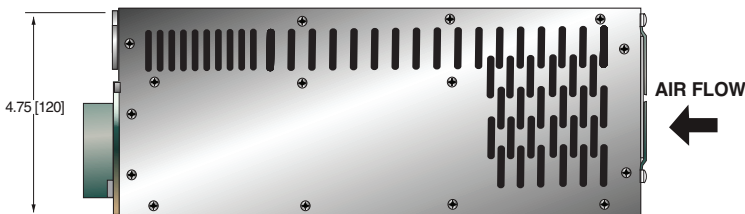

Positive Polarity - Ground Filament

BOTTOM VIEW

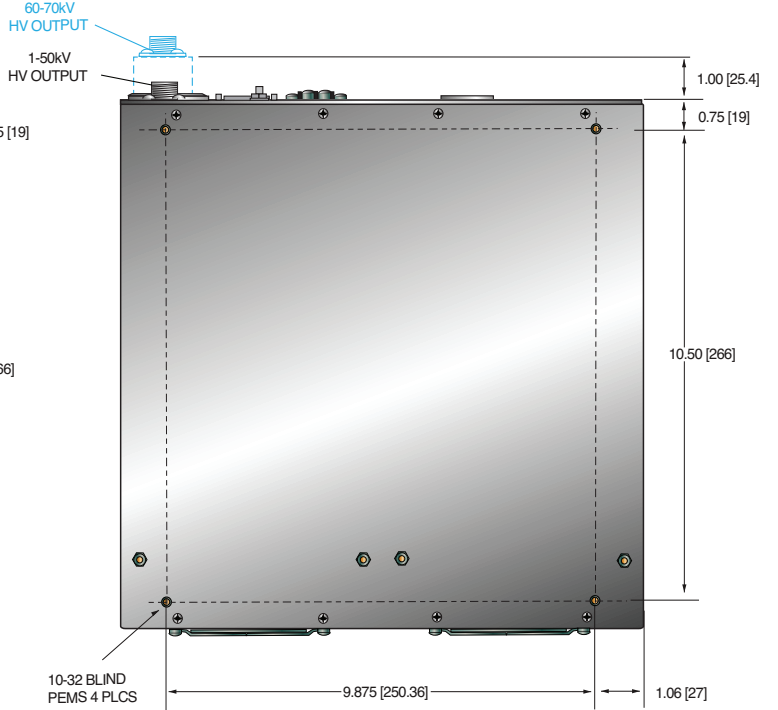

FRONT VIEW

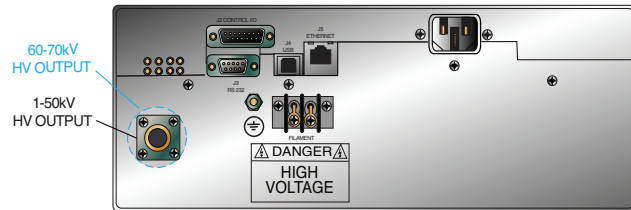

SIDE VIEW

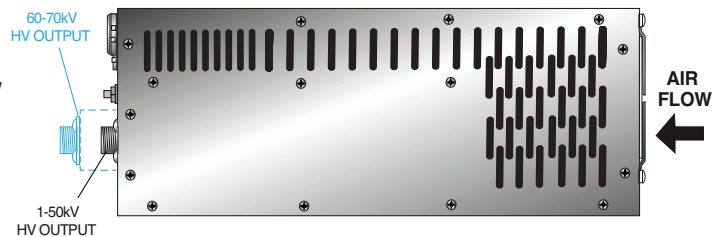

DIMENSIONS: in.[mm]

160kV

TOP VIEW



FRONT VIEW

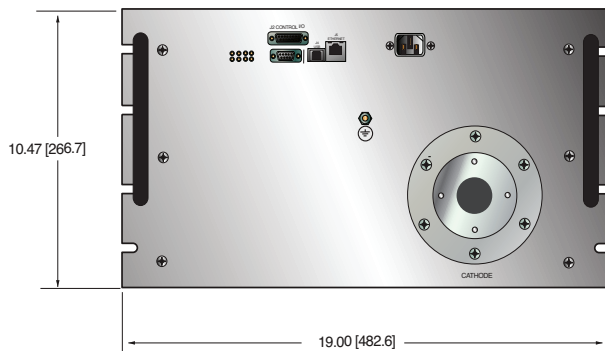

SIDE VIEW

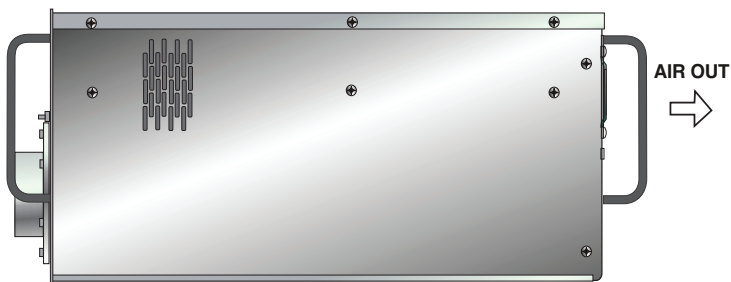



- **Bipolar Outputs in a Single Unit**
- **Compact & Lightweight**
- **Models from 40kV to 320kV, 300W, 600W and 1200W**
- **Universal Input, Power Factor Corrected**
- **Standard Digital Interfaces: USB, Ethernet and RS-232**
- **CE Compliant, UL Recognized**

www.spellmanhv.com/manuals/DXB

Spellman's new DXB Series of bipolar X-Ray generator modules are designed for OEM applications up to 320kV (± 160 kV) at 1200 watts. Its universal input, small package size and choice of three standard digital interfaces simplifies integrating the DXB into your X-Ray analysis system. DSP based emission control circuitry provides excellent regulation of emission current, along with outstanding stability performance.

TYPICAL APPLICATIONS

- | | |
|---------------------|--------------------|
| Plastics Sorting | Mineral Analysis |
| Crystal Inspection | X-Ray Fluorescence |
| Plating Measurement | X-Ray Diffraction |
| Thickness Gauging | Cargo Screening |
| Food Inspection | |

SPECIFICATIONS

Input Voltage:

- Power factor corrected input
- 90-264Vac: 47-63Hz @ 4.0A for 300 watt units
- 180-264Vac: 47-63Hz @ 7.9A for 600 watt units
- 47-63Hz @ 7.9A for 1200 watt units

Output Voltage:

- 7 models: 40kV, 60kV, 80kV, 100kV, 120kV, 140kV and 320kV

Output Polarity:

- \pm bipolar output, filament referenced to negative output

Power:

- 3 power ranges available—300 watts, 600 watts and 1200 watts
- Other power levels available on special order.

Output Voltage Regulation:

- $\leq 0.01\%$ of rated output voltage over specified input voltage range
- $\leq 0.01\%$ of rated output voltage for a full load change

Emission Current Regulation:

- $\leq 0.01\%$ of rated output current over specified input voltage range
- $\leq 0.01\%$ of rated output current for a change from 30% to 100% of rated output voltage
- Filament is disabled when kV is $< 30\%$ of full scale output

Ripple:

- $\leq 1\%$ rms at > 20 kHz, 0.1% rms below 20 kHz

Stability:

- ≤ 25 ppm/hr after a 2 hour warm up

Temperature Coefficient:

- ≤ 50 ppm per degree C

Environmental:

- Temperature Range:
 Operating: 0°C to 40°C
 Storage: -40°C to 85°C
- Humidity:
 20% to 85% RH, non-condensing.

Filament Configuration:

- Closed loop emission control regulates filament setting to provide desired X-Ray tube emission current.
- Floating Filament (ac output referenced to negative output voltage).

Output: 0-5 amps at a compliance of 10 volts, maximum.

- The filament loop is disabled when the kV output is less than 30% of full scale output to protect the X-Ray tube. Standard filament Preheat adjustable 0-2.5 amps. Other filament levels available on special order.

Control Interface

- Local Interface:** Potentiometers are provided to adjust filament limit and preheat levels
- Remote Interface:** USB, Ethernet and RS-232 are standard. All digital monitors have an accuracy specification of 2%
- Control Software:** A Windows graphical user interface example is provided. Built-in diagnostics can be performed over Ethernet via a Java applet and any standard web browser
- High Voltage Enable:** A hardware based, dry contact closure will enable the power supply into the high voltage on mode
- Monitor Signals:** Voltage and current monitor signals are scaled 0-10Vdc equals 0-100% of full scale, accuracy is 1%

Cooling:

- Forced air

Dimensions:

- 40-140kV:
 4.75" H X 12" W X 12" D (120.65mm x 304.8mm x 304.8mm)
- 320kV:
 10.5" H X 19.0" W X 21.5" D (266.7mm x 482.6mm x 546.1mm)

Weight:

- 40-140kV: 26 pounds (11.8kg)
- 320kV: 150 pounds (55.98kg)

Input Line Connector:

IEC320 with EMI filter

Output Connectors:

40-140kV:

Claymont Mini Federal Standard X-Ray connectors.

Other connectors and pinouts available on special order.

320kV:

R24 X-Ray connectors.

Other connectors and pinouts available on special order.

Regulatory Approvals:

Compliant to EEC EMC Directive. Compliant to EEC

Low Voltage Directive. UL/CUL recognized, File E227588.

RoHS Compliant.

DXB SELECTION TABLE— 300W, 600W, 1200W

300 Watt			600 Watt		1200 Watt	
kV	mA	Model	mA	Model	mA	Model
40	7.50	DXB40PN300	15.0	DXB40PN600	30.0	DXB40PN1200
60	5.00	DXB60PN300	10.0	DXB60PN600	20.0	DXB60PN1200
80	3.75	DXB80PN300	7.50	DXB80PN600	15.0	DXB80PN1200
100	3.00	DXB100PN300	6.00	DXB100PN600	12.0	DXB100PN1200
120	2.50	DXB120PN300	5.00	DXB120PN600	10.0	DXB120PN1200
140	2.14	DXB140PN300	4.28	DXB140PN600	8.57	DXB140PN1200
320	Not Available		Not Available		3.75	DXB320PN1200

DXB ANALOG INTERFACE— J2 15 PIN MALE D CONNECTOR

PIN	SIGNAL	SIGNAL PARAMETERS
1	Power Supply Fault	Open Collector, 35V @ 10mA Maximum
2	Current Program In	0 to 10V=0 to 100% Rated Output, Zin=10MΩ
3	Voltage Program In	0 to 10V=0 to 100% Rated Output, Zin=10MΩ
4	Filament Limit Input	0 to 10V=0 to 100% Rated Output, Zin=10MΩ
5	Local Filament Limit	Multi-turn front panel potentiometer
6	Filament Preheat Input	0 to 10V=0 to 100% Rated Output, Zin=10MΩ
7	Local Filament Preheat	Multi-turn front panel potentiometer
8	Voltage Monitor	0 to 10V=0 to 100% Rated Output, Zout =4.99k, 1%
9	Signal Ground	Ground
10	Current Monitor	0 to 10V=0 to 100% Rated Output, Zout =4.99k, 1%
11	X-Ray Enable Input	Connect to Pin 12 to HV Enable Supply
12	X-Ray Enable Output	+15V @ Open, ≤15mA @ Closed
13	Filament Monitor	1 Volt=1 Amp, Zout=10kΩ
14	X-Ray On Output Signal	Open Collector, 35V @10mA Maximum
15	Spare	N/C

RS-232 DIGITAL INTERFACE— J3 9 PIN FEMALE D CONNECTOR

PIN	SIGNAL	SIGNAL PARAMETERS
1	N/C	No Connection
2	TX out	Transmit Data
3	RX in	Receive Data
4	N/C	No Connection
5	SGND	Ground
6	N/C	No Connection
7	N/C	No Connection
8	N/C	No Connection
9	N/C	No Connection

USB DIGITAL INTERFACE— J4 4 PIN USB “B” CONNECTOR

PIN	SIGNAL	SIGNAL PARAMETERS
1	VBUS	+5 Vdc
2	D-	Data -
3	D+	Data +
4	GND	Ground

ETHERNET DIGITAL INTERFACE— J5 8 PIN RJ45 CONNECTOR

PIN	SIGNAL	SIGNAL PARAMETERS
1	TX+	Transmit Data +
2	TX-	Transmit Data -
3	RX+	Receive Data +
4	NC	No Connection
5	NC	No Connection
6	RX-	Receive Data -
7	NC	No Connection
8	NC	No Connection

CLAYMOUNT HV CONNECTOR PINOUT J6 CATHODE OUTPUT (40-140kV)

PIN	OUTPUT CONNECTION
C (common)	-High Voltage Output
S (small)	-High Voltage Output
L (large)	Filament Output
G (grid)	Filament Output

CLAYMOUNT HV CONNECTOR PINOUT J7 ANODE OUTPUT (40-140kV)

PIN	OUTPUT CONNECTION
C (common)	+High Voltage Output
S (small)	+High Voltage Output
L (large)	+High Voltage Output
G (grid)	+High Voltage Output

Note: No high voltage cable is provided

Recommended Cable:

Claymont part number: 12096

Cable assembly, L3 CA11, CA11, 10F, CS=Bare 10 foot, Mini Federal Connectors on both ends, "C" and "S" are both connected to the bare wire

R24 HV CONNECTOR PINOUT J6 CATHODE OUTPUT (320kV)

PIN	OUTPUT CONNECTION
C (common)	-High Voltage Output
S (small)	Filament Output
L (large)	Filament Output

R24 HV CONNECTOR PINOUT J7 ANODE OUTPUT (320kV)

PIN	OUTPUT CONNECTION
C (common)	+High Voltage Output
S (small)	+High Voltage Output
L (large)	+High Voltage Output

DIMENSIONS: in.[mm]

40-140kV

BOTTOM VIEW

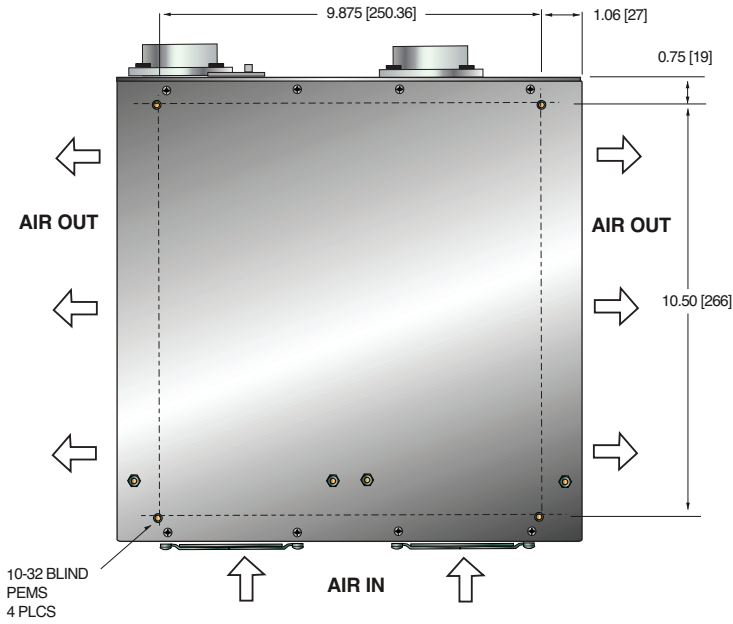

320kV

TOP VIEW

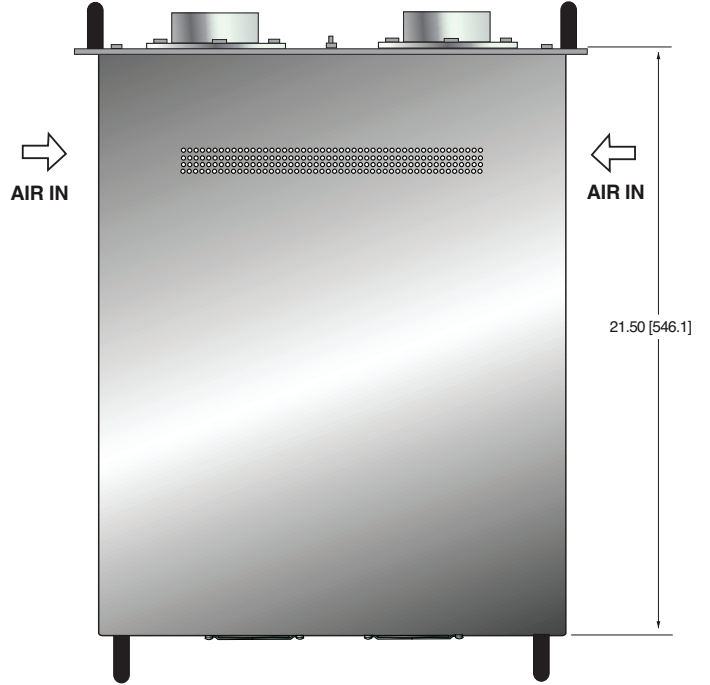

FRONT VIEW

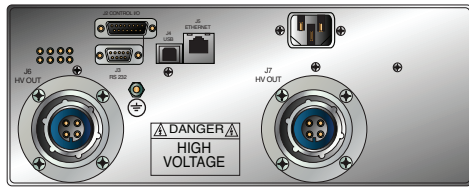

FRONT VIEW

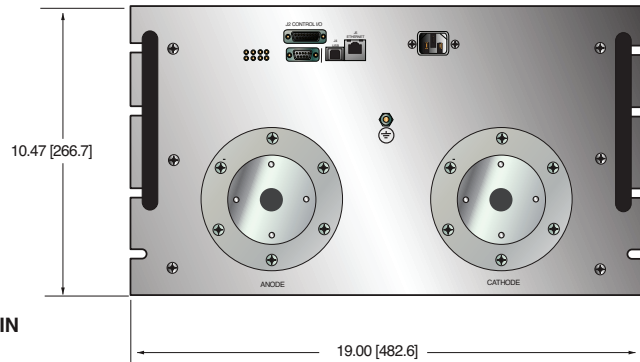

SIDE VIEW

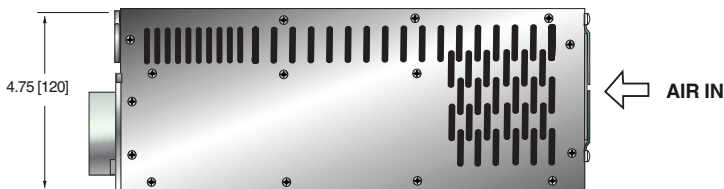

SIDE VIEW

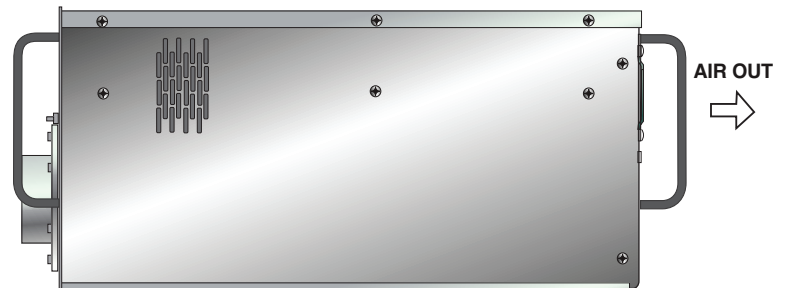



- **100kV @ 1200W**
- **Compact & Lightweight Modular Unit**
- **Universal Input, Power Factor Corrected**
- **Standard Digital Interfaces: USB, Ethernet and RS-232**
- **Programmable Power Trip Feature**
- **User Programmable Ramping and Arc Detect Feature**
- **CE Compliant**

www.spellmanhv.com/manuals/DXM100

Spellman's new DXM100 X-Ray generator module is designed for OEM applications up to 100kV at 1200 watts. Its universal input, small package size and choice of three standard digital interfaces simplifies integrating the DXM100 into your X-Ray analysis system. DSP based emission control circuitry provides excellent regulation of emission current, along with outstanding stability.

TYPICAL APPLICATIONS

NDT Analysis	Crystal Inspection
Plating Measurement	Diamond Inspection
Mineral Analysis	Food/Product Inspection

SPECIFICATIONS

Input Voltage:

Power factor corrected input, ≥ 0.98
180-264Vac, 47-63Hz, 8.25A maximum

Output Voltage:

100kV, maximum

Output Polarity:

Negative for floating filament X-Ray tubes

Output Current:

12mA maximum

Output Power:

1200 Watts maximum

Output Voltage Regulation:

$\leq 0.01\%$ of rated output voltage over specified input voltage range
 $\leq 0.01\%$ of rated output voltage for a full load change

Emission Current Regulation:

$\leq 0.01\%$ of rated output current over specified input voltage range
 $\leq 0.01\%$ of rated output current for a change from 30% to 100% of rated output voltage
Filament is disabled when kV is $< 30\%$ of full scale output

Ripple:

$\leq 1\%$ rms at > 20 kHz, 0.1% rms below 20 kHz

Stability:

≤ 25 ppm/hr after a 2 hour warm up

Temperature Coefficient:

≤ 50 ppm per degree C

Environmental:

Temperature Range:
Operating: 0°C to 40°C
Storage: -40°C to 85°C

Humidity:

20% to 85% RH, non-condensing.

Filament Configuration:

Closed loop emission control regulates filament setting to provide desired X-Ray tube emission current.

Output: 5.0 amps at a compliance of 10.0 volts, maximum.
The filament loop is disabled when the kV output is less than 30% of full scale output to protect the X-Ray tube. Standard filament Preheat adjustable 0-2.5 amps. Other filament levels available on special order.

Control Interface:

Local Interface:

Potentiometers are provided to adjust filament limit and preheat levels

Remote Interface: USB, Ethernet and RS-232 are standard. All digital monitors have an accuracy specification of 2%

Control Software: A Windows graphical user interface example is provided. Built-in diagnostics can be performed over Ethernet via a Java applet and any standard web browser

High Voltage Enable: A hardware based, dry contact closure will enable the power supply into the high voltage on mode

Monitor Signals: Voltage and current monitor signals are scaled 0-10Vdc equals 0-100% of full scale, accuracy is 1%

Over Power Fault: The maximum power the unit can supply can be programmed (0-1200 watts) via the digital interface, this setting will be stored in memory. An over power fault will occur if the output power is $\geq 105\%$ of the set point value. When an over power fault occurs the high voltage output will be disabled and the Over Power Fault indicator will be activated on the GUI/Applet. Additionally both the UV and OV fault LED's on the DXM100 will be illuminated.

Cooling:

Forced air

Dimensions:

6.25" H X 12" W X 15.5" D (158.75mm x 304.79mm x 393.7mm)

Weight:

43 pounds (19.5kg)

Input Line Connector:

IEC320 with EMI filter, 6' (1.83 meter) cord set provided

Output Connector:

CA10 (R10). See table for pin out information

Regulatory Approvals:

Compliant to EEC EMC Directive. Compliant to EEC Low Voltage Directive. UL/CUL recognized, File E227588. RoHS Compliant.

DXM100 ANALOG INTERFACE – J2 15 PIN MALE D CONNECTOR

PIN	SIGNAL	SIGNAL PARAMETERS
1	Power Supply Fault	Open Collector, 35V @ 10mA Maximum
2	Current Program In	0 to 10V=0 to 100% Rated Output, $Z_{in}=10M\Omega$
3	Voltage Program In	0 to 10V=0 to 100% Rated Output, $Z_{in}=10M\Omega$
4	Filament Limit Input	0 to 10V=0 to 100% Rated Output, $Z_{in}=10M\Omega$
5	Local Filament Limit	Multi-turn front panel potentiometer
6	Filament Preheat Input	0 to 10V=0 to 100% Rated Output, $Z_{in}=10M\Omega$
7	Local Filament Preheat	Multi-turn front panel potentiometer
8	Voltage Monitor	0 to 10V=0 to 100% Rated Output, $Z_{out}=4.99k$, 1%
9	Signal Ground	Ground
10	Current Monitor	0 to 10V=0 to 100% Rated Output, $Z_{out}=4.99k$, 1%
11	X-ray Enable Input	Connect to Pin 12 to HV Enable Supply
12	X-ray Enable Output	+15V @ Open, $\leq 15mA$ @ Closed
13	Filament Monitor	1 Volt=1 Amp, $Z_{out}=10k\Omega$
14	X-ray On Output Signal	Open Collector, 35V @10mA Maximum
15	Spare	NC

Typical DXM100 Cable Wiring

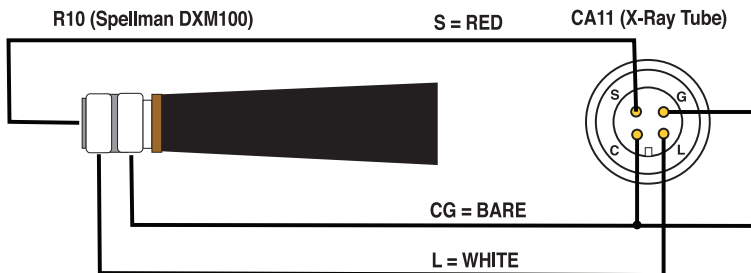

RS-232 DIGITAL INTERFACE – J3 9 PIN FEMALE D CONNECTOR

PIN	SIGNAL	SIGNAL PARAMETERS
1	NC	No Connection
2	TX out	Transmit Data
3	RX in	Receive Data
4	NC	No Connection
5	SGND	Ground
6	NC	No Connection
7	NC	No Connection
8	NC	No Connection
9	NC	No Connection

USB DIGITAL INTERFACE – J4 4 PIN USB “B” CONNECTOR

PIN	SIGNAL	SIGNAL PARAMETERS
1	VBUS	+5 Vdc
2	D-	Data -
3	D+	Data +
4	GND	Ground

ETHERNET DIGITAL INTERFACE – J5 8 PIN RJ45 CONNECTOR

PIN	SIGNAL	SIGNAL PARAMETERS
1	TX+	Transmit Data +
2	TX-	Transmit Data -
3	RX+	Receive Data +
4	NC	No Connection
5	NC	No Connection
6	RX-	Receive Data -
7	NC	No Connection
8	NC	No Connection

J6 CA10 (R10) HV CONNECTOR

PIN	OUTPUT CONNECTION
C (common)	High Voltage Output
S (small)	High Voltage Output
L (large)	Filament Output

Note: No high voltage cable is provided

DIMENSIONS: in.[mm]

BOTTOM VIEW

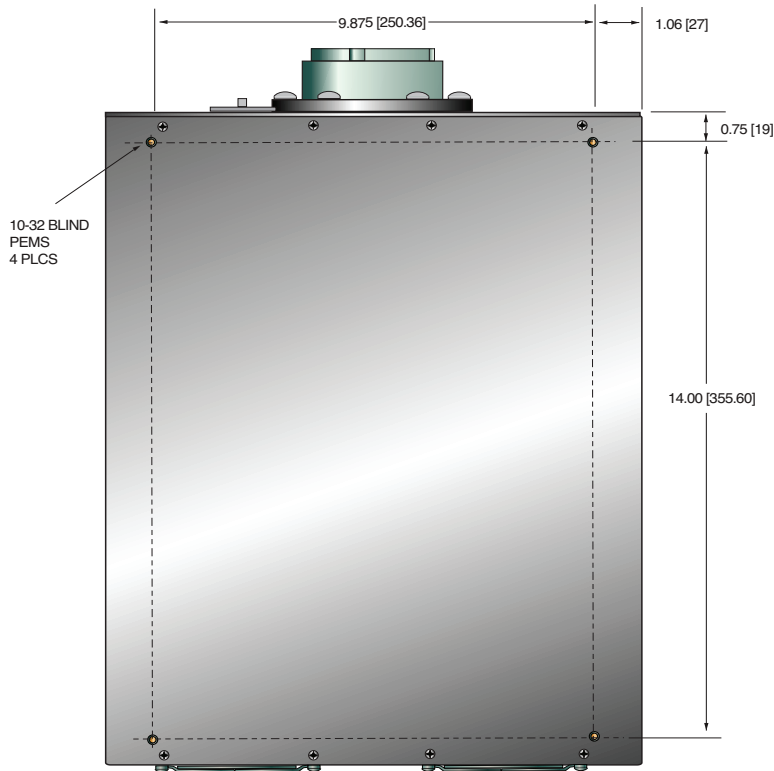

FRONT VIEW

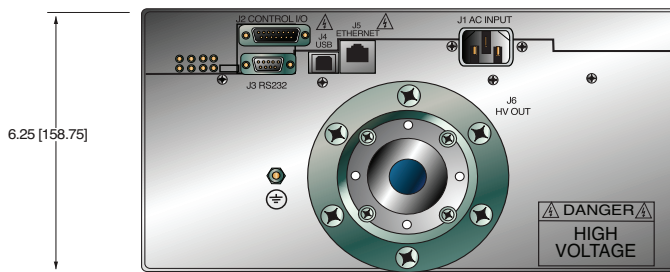

HIGH VOLTAGE MATING FLANGE BOLT CIRCLE DETAIL

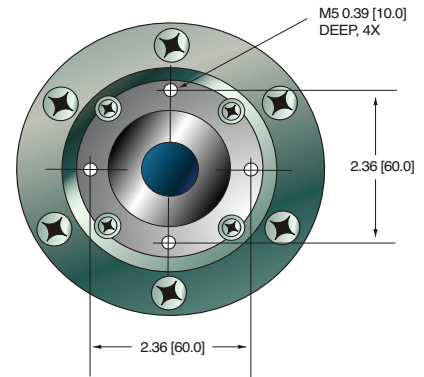

SIDE VIEW

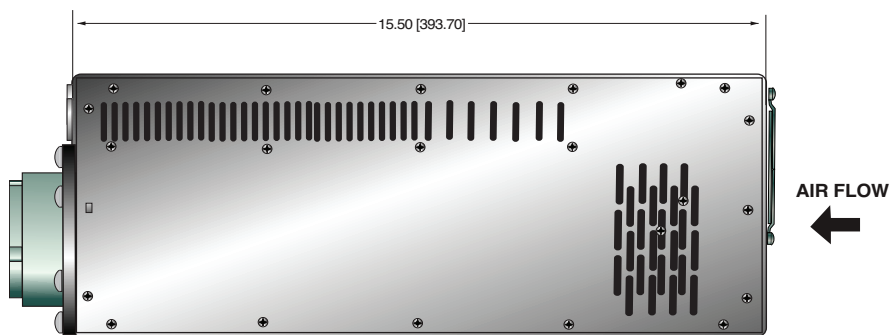



Spellman's XLF Series of X-Ray generators are well regulated high voltage power supplies with output voltages to 60kV and very low ripple achieved through the use of advanced resonant conversion techniques. Extremely stable voltage and emission current outputs result in significant performance improvements over previously available technology. The XLF Series provides power, control and support functions required for X-Ray applications including a regulated ac filament supply referenced to the cathode. These units also incorporate local and remote programming, monitoring, safety interlock, short-circuit and overload protection.

TYPICAL APPLICATIONS

Plastics Sorting
Crystal Inspection
Diamond Inspection

OPTIONS

APT Adjustable Power Trip
AT Arc Trip
SS(x) Non-Standard Slow Start
NSS No Slow Start
IO Instant ON
SL Slides

FRONT PANEL STATUS INDICATORS:

Overvoltage	Voltage Control Mode
Overtemperature	Current Control Mode
Regulation Error	Interlock Open
Arc	Interlock Closed
HV ON: Red	HV OFF: Green

SPECIFICATIONS

Input Voltage:

XLF 600W:
115Vac ±10% @ 11.4A, 50-60Hz single phase
220Vac ±10% @ 5.9A, 50-60Hz single phase

XLF 1200W:
220Vac ±10% @ 11.8A, 50-60Hz single phase

Voltage and Current Control:

Local: continuously adjustable from zero to maximum rating via a ten-turn potentiometer
Remote: 0 to +10Vdc proportional from 0 to full output
Accuracy: ±1%
Input Impedance: 10Mohm

- **Output Voltages to 60kV**
- **Integrated Floating Filament Supply**
- **Low Ripple**
- **“Hot Cathode”**
- **Negative Polarity**
- **Local & Remote Programming**
- **OEM Customization Available**

www.spellmanhv.com/manuals/XLF

Filament:

12 volts @ 5 amps, preheat level is 0.45 amps in standby

Voltage Regulation:

Load: 0.005% of full output voltage no load to full load
Line: 0.005% for input voltage range change

Current Regulation:

Load: 0.05% of full current ±100µA from 0 to full voltage
Line: 0.05% of rated current over specified input range

Ripple:

0.03% rms below 1kHz
0.75% rms above 1kHz

Temperature Coefficient:

100ppm/°C.

Stability:

0.01%/8 hrs after 1/2 hour warm-up
0.02% per 8 hours (typical)

Cooling:

Fan cooled

Metering:

Digital voltage and current meters (3.5 digits),
1% accuracy

Voltage and Current Monitors:

0 to +10Vdc proportional to rated output

HV Output:

75kV, 3 conductor Federal Standard X-Ray connector

I/O Connectors:

25 pin D-type for control interface with mating connector provided

Dimensions:

3.5”H x 19”W x 20”D (8.9cm x 48.3cm x 50.8cm)

Regulatory Approvals:

Compliant to EEC EMC Directive. Compliant to EEC Low Voltage Directive. RoHS Compliant.

Electronic Component (Power Source)

XLF series is intended for installation as a component of a system.

It is designed to meet CE standards, with conditions of acceptance often being: customer provided enclosure mounting, EMC filtering, and appropriate protection, and isolation devices. The XLF series is not intended to be operated by end users as a stand-alone device. The XLF series power supply can only be fully assessed when installed within a system, and as a component part within that system.

600W, 1200W XLF SELECTION TABLE

600 Watt			1200 Watt		
kV	mA	Model	kV	mA	Model
30	20	XLF30N600	30	40	XLF30N1200
40	15	XLF40N600	40	30	XLF40N1200
50	12	XLF50N600	50	24	XLF50N1200
60	10	XLF60N600	60	20	XLF60N1200

JB1 CONNECTOR 25 PIN

PIN	SIGNAL	SIGNAL PARAMETERS
1	Power Supply Common	Signal Ground
2	External Inhibit	Ground=Inhibit, Open=HV On
3	External Interlock	+15V at Open, <15mA at Closed
4	External Interlock Return	Return for Interlock
5	Current Monitor	0 to 10V=0 to 100% Rated Output
6	kV Test Point	0 to 10V=0 to 100% Rated Output
7	+10V Reference	+10Vdc @ 1mA Max
8	Remote Current Program In	0 to 10V=0 to 100% Rated Output
9	Local Current Program Out	Front Panel Program Voltage
10	Remote Voltage Program In	0 to 10V=0 to 100% Rated Output
11	Local Voltage Program Out	Front Panel Program Voltage
12	Power Monitor	0 to 10V=0 to 100% Rated Output (Optional)
13	Remote Power Program In	
14	Local HV Off Out	+15V at Open, <25mA at Closed
15	HV Off	Connect to HV OFF for Fp Operation
16	Remote HV On	+15V, 10mA Max=HV Off
17	Remote HV Off Indicator	0=HV On, +15V, 10mA Max=HV Off
18	Remote HV On Indicator	0=HV Off, +15V, 10mA Max=HV On
19	Remote Voltage Mode	
20	Remote Current Mode	Open Collector 50V Max, 10mA Max
21	Remote Power Mode	On=Active
22	Remote PS Fault	0=Fault, +15V, 0.1mA Max=No Fault
23	+15V Output	+15V, 100mA Max
24	Power Supply Common	Signal Ground
25	Shield Return	Shield Return

HIGH VOLTAGE CONNECTOR PINOUT

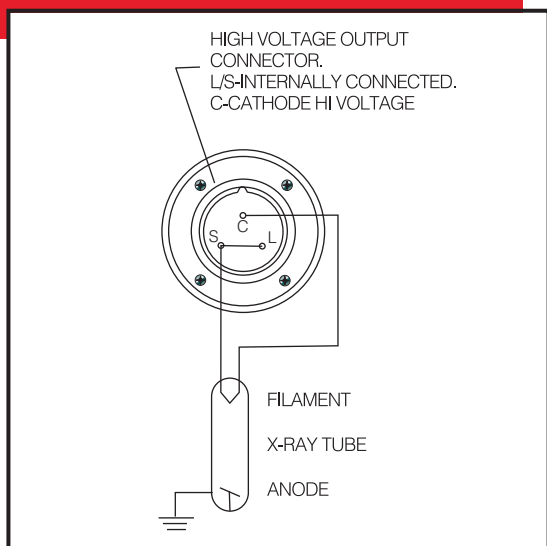

DIMENSIONS: in.[mm]

FRONT VIEW

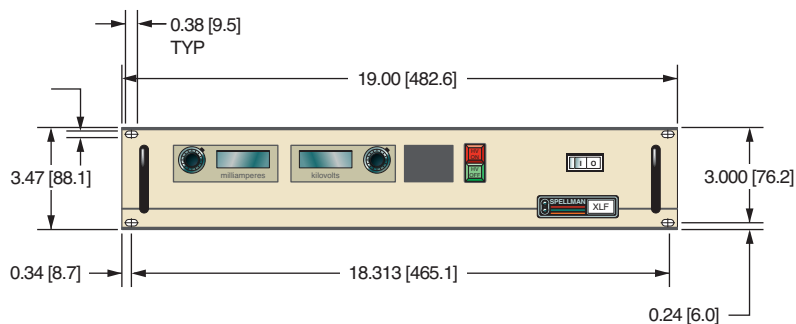

TOP VIEW

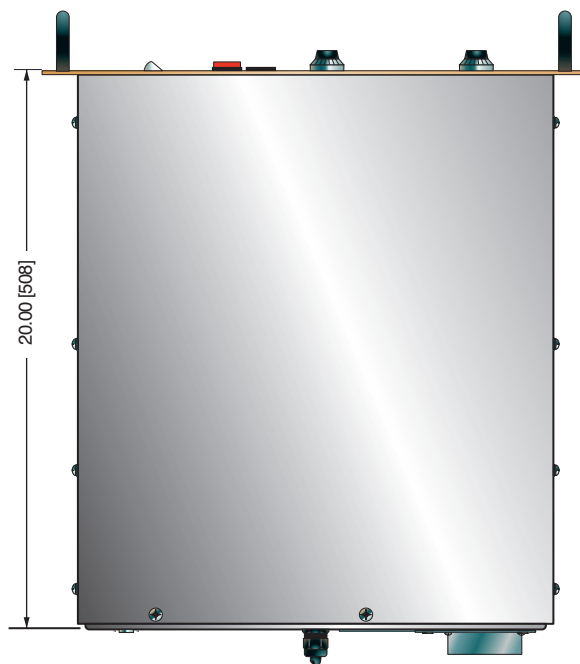

BACK VIEW

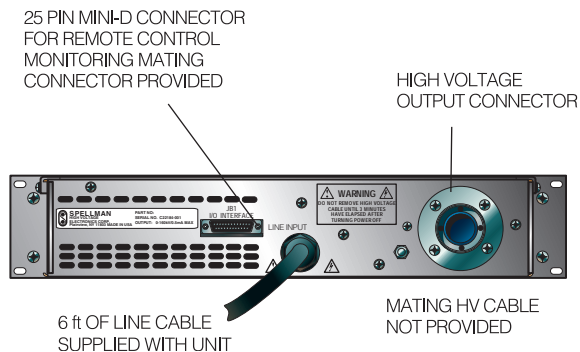



NOW AVAILABLE

1800 Watt units specifically designed for the HP and HPX families of X-Ray tubes used in high speed digital and industrial CT applications.

- **160kV, 225kV, 320kV, 350kV and 450kV Models**
- **Complete X-Ray Generator Package**
- **Power Factor Corrected AC Input Circuitry**
- **Integrated Dual Filament Supplies**
- **Digital Interface—USB, Ethernet and RS-232**
- **Excellent Stability and Regulation**
- **Available with Black Powder Coated Finish**

www.spellmanhv.com/manuals/XRV

Spellman's XRV series of X-Ray high voltage power supplies sets the standard for compact 1.8kW to 6.0kW, high performance X-Ray inspection generators. Spanning an output voltage range of 160kV to 450kV in negative, positive or bipolar output configurations, there's a model available for virtually every application requirement.

Active power factor correction circuitry reduces input current requirements while minimizing line related EMI. Spellman's proprietary inverter topology allows for unprecedented efficiencies and power densities. A solid encapsulated high voltage section further reduces size and weight and provides reliable, maintenance free operation.

DSP based SMT control circuitry provides your choice of USB, Ethernet and RS-232 along with analog interfacing, simplifying OEM system integration. The two DC output, current regulated filament power supplies are controlled via sophisticated emission current regulation circuitry to provide accurate and stable X-Ray tube currents. Comprehensive fault diagnostic circuitry, and Arc Sense, Arc Quench and Arc Count functionality is also incorporated into this compact, space saving X-Ray generator.

TYPICAL APPLICATIONS

- Non Destructive Testing
- X-Ray Scanning
- Security Applications
- Medical Applications

OPTIONS

- 400Vac ±10% (6kW only)**
- GUI Control Software for XRV**
- XRVC (XRV Controller)**

SPECIFICATIONS

Input Voltage:

1.8kW, 3.0kW, 4.0kW and 4.5kW models:

180-264Vac, single phase, 47-63 Hertz, active power factor corrected input to ≥0.98

6.0kW models:

208 or 400Vac, ±10%, three phase, 47-63 Hertz, passive power factor corrected

Input Current:

1.8kW, 3.0kW, 4.0kW and 4.5kW models: <30 amps

6.0kW models: <25 amps per phase for 208Vac

<15 amps per phase for 400Vac

Output Voltage:

Accuracy: 0.25%

Stability: ≤0.1% per 8 hours, after 1 hour warm up

1.8kW, 3.0kW, 4.0kW and 4.5kW models:

Load: ±0.05% of rated output voltage for a full load change

Line: ±0.05% of rated output voltage over specified input voltage range

6.0kW models:

Load: ±0.1% of rated output voltage for a full load change

Line: ±0.1% of rated output voltage over specified input voltage range

Output Polarity:

See "model selection" table

Output Current:

See "model selection" table

Ripple:

See "model selection" table

Temperature Coefficient:

1.8kW, 3.0kW, 4.0kW and 4.5kW models:

±50ppm/°C

6.0kW models:

±50ppm/°C

Emission Current:

Accuracy: 0.25%

Stability: 100ppm/°C

1.8kW, 3.0kW, 4.0kW and 4.5kW models:

Load: ±0.05% of rated output current for a change from 30% to 100% of rated output voltage

Line: ±0.05% of rated output current over specified input voltage range

6.0kW models:

Load: ±0.1% of rated output current for a change from 30% to 100% of rated output voltage

Line: ±0.1% of rated output current over specified input voltage range

Filament:

Output:

0-6 amps at a compliance of 10Vdc, maximum

Dual Focal Spot:

Small and large, selectable via interface signal

Configuration:

DC filament drive. Closed loop emission control regulates filament setting to provide desired X-Ray tube emission current

Control Interface:

Remote Interface:

Analog, USB, Ethernet and RS-232 are standard

Control Software:

A VB GUI is provided for RS-232/USB, the Ethernet interface has an embedded applet for control (see side bar)

Environmental:

Temperature Range:

Operating: 0°C to 50°C

Storage: -40°C to 85°C

Humidity:

20% to 85% RH, non-condensing.

Mains Input Connector:

1.8kW, 3.0kW, 4.0kW and 4.5kW models:

Type 97-3102A-24-11P

6.0kW models:

Type 97-3102A-24-22P

Interface Connectors:

Digital—Ethernet, RS-232 and USB

Analog—25 pin connector

Output Connector:

See “model selection” table

Cooling:

Forced air

Regulatory Approvals:

Compliant to EEC EMC Directive/Compliant to EEC Low Voltage Directive, all but 6000 watt unit. NFC 74-100 compliant. UL/CUL recognized, File E227588, all but 6000 watt unit. RoHS Compliant.

GUI Control Software for the XRV



- Automatic warm-up of the X-Ray tube
- Max watts operation
- Timed or Continuous Exposure modes
- Configuration menu for user options setting of HVPS
- Fault and status monitor

GUI is specifically designed for controlling XRV series power supplies. As an alternative to the analog control, the GUI will allow the user to control all necessary functions of the HVPS from a user-friendly windows based menu. Additionally the GUI can be used as a diagnostic tool when the HVPS is controlled via the analog interface.



XRV160/320/350 SPECIFICATIONS

	XRV160*1800	XRV160*3000	XRV160*4000	XRV160*6000	XRV320P&N1800	XRV320P&N4500	XRV350P&N4500
DC Output Voltage	0 to 160kV	0 to 160kV	0 to 160kV	0 to 160kV	0 to ±160kV	0 to ±160kV	0 to ±175kV
Polarity*	Pos or Neg	Pos or Neg	Pos or Neg	Pos or Neg	Bipolar	Bipolar	Bipolar
Output Rated Current	0-30mA	0-30mA	0-50mA	0-50mA	0-30mA	0-30mA	0-30mA
Output Power	1.8kW	3.0kW	4.0kW	6.0kW	1.8kW	4.5kW	4.5kW
Ripple/Noise (p-p)	<0.025%	<0.05%	<0.1%	<0.25%	<0.025%	<0.1%	<0.1%
Dimensions	10.09" H x 17.16" W x 24" D (256mm x 436mm x 609mm)				2X 10.09" H x 17.16" W x 24" D (256mm x 436mm x 609mm)		
Weight	150 lbs. (68kg)	150 lbs. (68kg)	150 lbs. (68kg)	155 lbs. (70.3kg)	300 lbs. (136 kg)	300 lbs. (136 kg)	300 lbs. (136 kg)
Output Connector	R24	R24	R24	R24	Two R24	Two R24	Two R24

XRV225/450 SPECIFICATIONS

	XRV225*1800	XRV225*3000	XRV225*4000	XRV225*6000	XRV450P&N1800	XRV450P&N4500
DC Output Voltage	0 to 225kV	0 to 225kV	0 to 225kV	0 to ±225kV	0 to ±225kV	0 to ±225kV
Polarity*	Pos or Neg	Pos or Neg	Pos or Neg	Pos or Neg	Bipolar	Bipolar
Output Rated Current	0-30mA	0-30mA	0-30mA	0-30mA	0-30mA	0-30mA
Output Power	1.8kW	3.0kW	4.0kW	6.0kW	1.8kW	4.5kW
Ripple/Noise (p-p)	<0.025%	<0.05%	<0.1%	<0.25%	<0.025%	<0.1%
Dimensions	15.90" H x 17" W x 30.72" D (404mm x 432mm x 780mm)				2X 15.90" H x 17" W x 30.72" D (404mm x 432mm x 780mm)	
Weight	240 lbs. (109kg)	240 lbs. (109kg)	240 lbs. (109kg)	240 lbs. (109kg)	480 lbs. (218 kg)	480 lbs. (218 kg)
Output Connector	R28**	R28**	R28**	R28**	Two R28**	Two R28**

Units are available in positive output polarity without filament, see model selection table for ordering details.

*Specify "P" for positive or "N" for negative polarity.

**Order SHV HV cable flange p/n 407141-024 if using Comet HV cable with R28SL spring loaded plug.



Corporate Headquarters
 Hauppauge, New York USA
 +1-631-630-3000 FAX: +1-631-435-1620
 e-mail: sales@spellmanhv.com

www.spellmanhv.com

Spellman High Voltage is an ISO 9001:2008 and ISO 14001:2004 registered company

Copyright © 2007 Spellman High Voltage Electronics Corp.

128060-001 REV. W

J1 HV CONNECTOR—R24/R28

PIN	SIGNAL	PARAMETERS
C	HV Output	XRV160 and XRV320—R24 Connector XRV225 and XRV450—R28 Connector
S	Small Filament Output	0 to 6 amps @ 10Vdc
L	Large Filament Output	0 to 6 amps @ 10Vdc

J2 ANALOG INTERFACE—25 PIN D CONNECTOR

PIN	SIGNAL	PARAMETERS
1	Power Supply Fault	Low, sum of faults, HVPS detected a fault, open collector, 50V @ 10mA max
2	mA Program	0 to 10V FS Z in = 10M ohms
3	kV Program	0 to 10V FS Z in = 10M ohms
4	Filament Limit L/S Ref.*	0 to 10V FS Z in = 10M ohms
5	Filament Preheat L/S Ref.*	0 to 10V FS Z in = 10M ohms
6	kV Monitor	0 to 10V FS Z out = 4.99k ohms
7	mA Monitor	0 to 10V FS Z out = 4.99k ohms
8	Filament Current Monitor*	0 to 10V FS Z out = 4.99k ohms
9	Signal Ground	Ground
10	X-Ray Enable	+24Vdc = X-Ray ON, connect to pin 14 with dry contact relay
11	Filament ON*	Filament ON status, low, filament is ON open collector 50V, @ 10mA max
12	Interlock 1	Active low, interlock is closed, safe to enable HV
13	Interlock 2	Active low, interlock is closed, safe to enable HV
14	+24Vdc	+24Vdc @ 100mA, maximum
15	Filament Enable*	Active low, turn filament ON
16	Filament Control*	Active low, filament is regulated by ECR (HV must be ON). Not active, the filament is regulated by the preheat reference
17	Filament L/S Select	Filament selection large or small, low = small spot is selected
18	Filament L/S Confirm	Open collector, 50V @ 10mA max Filament selection confirm, low = small spot is selected
19	HVPS RDY	Low = HVPS ready, open collector, 50V @ 10mA max
20	X-Ray ON	X-Ray ON status, low = X-Rays are ON open collector, 50V @ 10mA max
21	Interlock Status	Low, interlocks are closed, can enable HV open collector, 50V @ 10mA max
22	GND	Digital ground
23	X-Ray ON Pre-Warn	Pre-warning, low, before X-Ray ON open collector, 50V @ 10mA max
24	Reset	Active low, minimum 10mS transition
25	Arc fault	Low, arc fault, the HVPS has detected an arc open collector, 50V @ 10mA max

*Not active on positive models

MODEL SELECTION TABLE

MODEL	VOLTAGE	POWER	POLARITY
XRV160*1800	160kV	1.8kW	Pos or Neg
XRV160*3000	160kV	3.0kW	Pos or Neg
XRV160*4000	160kV	4.0kW	Pos or Neg
XRV160*6000/208V	160kV	6.0kW	Pos or Neg
XRV160*6000/400V	160kV	6.0kW	Pos or Neg
XRV225*1800	225kV	1.8kW	Pos or Neg
XRV225*3000	225kV	3.0kW	Pos or Neg
XRV225*4000	225kV	4.0kW	Pos or Neg
XRV225*6000/208V	225kV	6.0kW	Pos or Neg
XRV225*6000/400V	225kV	6.0kW	Pos or Neg
XRV320P&N1800	±160kV	1.8kW	Bipolar
XRV320P&N4500	±160kV	4.5kW	Bipolar
XRV350P&N4500	±175kV	4.5kW	Bipolar
XRV450P&N1800	±225kV	1.8kW	Bipolar
XRV450P&N4500	±225kV	4.5kW	Bipolar

*Specify P for positive polarity and N for negative polarity. Positive polarity models do not have integrated filament power supplies. Contact Spellman for custom output voltage/power models.

RS-232 DIGITAL INTERFACE—J3 9 PIN FEMALE D CONNECTOR

PIN	SIGNAL	PARAMETERS
1	N/C	No Connection
2	TX out	Receive Data
3	RX in	Transmit Data
4	N/C	No Connection
5	SGND	Ground
6	N/C	No Connection
7	N/C	No Connection
8	N/C	No Connection
9	N/C	No Connection

ETHERNET DIGITAL INTERFACE—J4 8 PIN RJ45 CONNECTOR

PIN	SIGNAL	PARAMETERS
1	TX+	Transmit Data +
2	TX-	Transmit Data -
3	RX+	Receive Data +
4	N/C	No Connection
5	N/C	No Connection
6	RX-	Receive Data -
7	N/C	No Connection
8	N/C	No Connection

USB DIGITAL INTERFACE—J5 4 PIN USB “B” CONNECTOR

PIN	SIGNAL	PARAMETERS
1	VBUS	+5 Vdc
2	D-	Data -
3	D+	Data +
4	GND	Ground

JB1 MAIN AND AUXILIARY INPUT POWER—TYPE 97-3102A-24-11P (Single Phase Units)

PIN	SIGNAL	PARAMETERS
A	Auxiliary AC Line Power	180-264Vac
B	Auxiliary Ground	Ground
C	Auxiliary AC Neutral	Neutral
D	Main AC Line Power	180-264Vac
E	Main Ground	Ground
F	Main AC Neutral	Neutral

JB1 MAIN AC INPUT POWER—TYPE 97-3102A-24-22P (Three Phase Units)

PIN	SIGNAL	PARAMETERS
A	Line 1	208Vac, ±10%, 50/60Hz @ 25 amps
B	Line 2	208Vac, ±10%, 50/60Hz @ 25 amps
C	Line 3	208Vac, ±10%, 50/60Hz @ 25 amps
D	GND	Ground

Note: Use 4 conductor cable or single isolated wires rated no less than 600Vac, 30 amps (10AWG, minimum)

JB2 AUXILIARY AC INPUT POWER—TYPE 97-3102A-20-3P (Three Phase Units)

PIN	SIGNAL	PARAMETERS
A	Line 1	208Vac, ±10%, 50/60Hz (source 3 phase L1, L2)
B	Line 2	208Vac, ±10%, 50/60Hz (source 3 phase L1, L2)
C	GND	Ground

System Ground: System ground wires (10AWG minimum) to the ground terminal E1 GND to the power supply using ground stud M6 X 20MM, with M6 nut.

XRV160

TOP VIEW

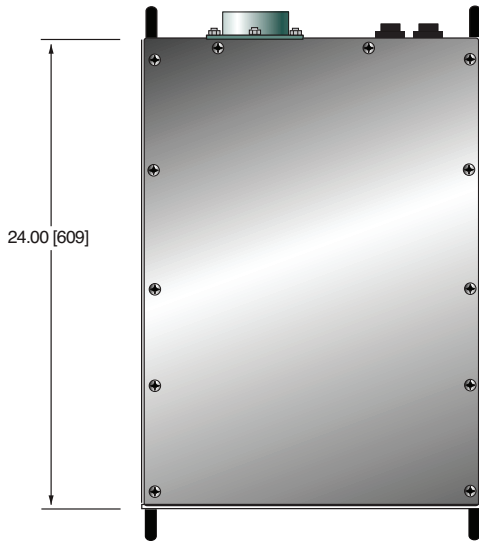

FRONT VIEW

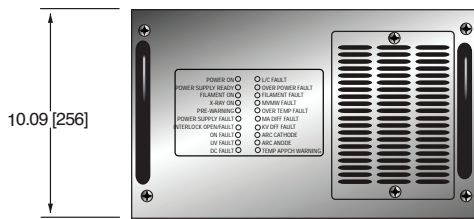

REAR VIEW

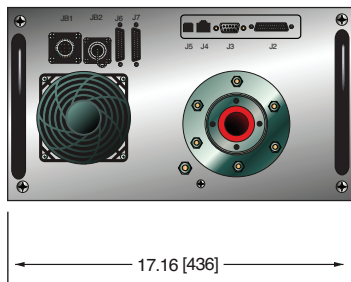

XRV320 is comprised of two XRV160 units configured in a bipolar arrangement

DIMENSIONS: in.[mm]

XRV225

TOP VIEW

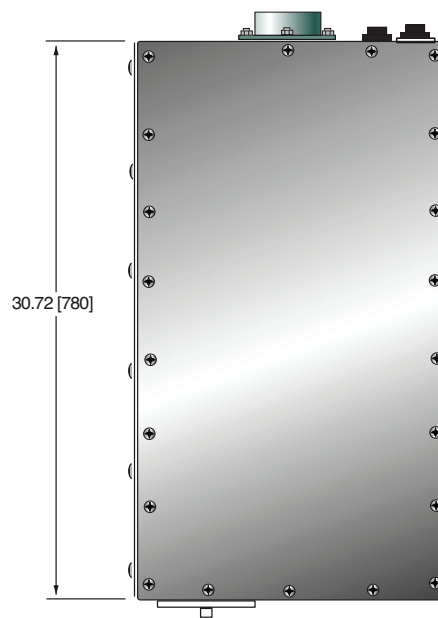

FRONT VIEW

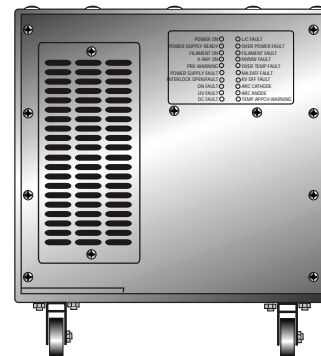

REAR VIEW

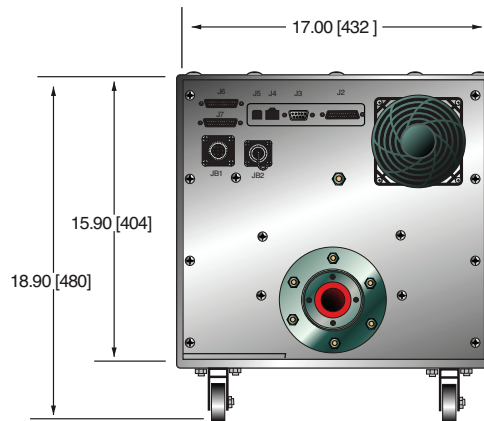

XRV450 is comprised of two XRV225 units configured in a bipolar arrangement





Spellman's DF/FF Series of X-Ray Generators feature our new inverter design which incorporates IGBTs for power switching and provides new levels of reliability. In addition, re-engineering of the DF/FF's internal filament power supply eliminates audio noise at normal operating levels by operating at a higher frequency. The DF/FF's utilize a sine wave current source, produced by phase shifting series resonant circuits at switching frequencies greater than 20kHz to generate high voltage dc. This technique eliminates undesirable electromagnetic radiation normally associated with switching and power control regulators. The high efficiency of these units allows for air cooling in a 5.25" (3U) high chassis.

TYPICAL APPLICATIONS

X-Ray Diffraction (XRD)
X-Ray Fluorescence (XRF)

OPTIONS

RS232	RS-232 Interface
220FSI	220Vac Fail Safe Interlock
208-3P	208Vac Three Phase Input

SPECIFICATIONS

Input Voltage:

220Vac \pm 10%, 50-60Hz, single phase (three phase optional)

Input Current:

3kW: 220Vac @ 29.5A, single phase
208Vac @ 12.8A/phase, three phase
4kW: 220Vac @ 39.3A, single phase
208Vac @ 17.0A/phase, three phase

Output Voltage:

DF3: 0 to 60kV negative polarity
FF3: 0 to 60kV positive polarity
Other output voltages are available

Output Current:

DF3: 0 to 80mA
FF3: 0 to 100mA
Other output currents are available

Maximum Output Power:

3kW (4kW optional)

Output Voltage Regulation:

Load: 0.005% of rated output for full load change
Line: 0.005% of rated output over specified input range
Temperature Coefficient: 50 ppm/ $^{\circ}$ C (20 ppm/ $^{\circ}$ C optional)
Long Term Stability: 0.01%/8 hours.

- **Ideal for Common XRD & XRF X-Ray Tubes**
- **Compact Size, 5 1/4" (3U) High Chassis**
- **Solid Encapsulation Insures Maintenance-Free Operation**
- **Auto Ramp of the HV Emission Current to Preset Values**
- **OEM Customization Available**

www.spellmanhv.com/manuals/DFFF

Emission Current Regulation:

Load: 0.01% of rated output for a 10 to 60kV change
Line: 0.005% of rated output over specified inputs
Temperature Coefficient: 50 ppm/ $^{\circ}$ C
Long Term Stability: 0.01%/8 hours

Ripple:

0.03% rms <1kHz, 0.75% rms above 1kHz

Environmental:

Temperature Range:
Operating: 0 $^{\circ}$ C to 40 $^{\circ}$ C
Storage: -20 $^{\circ}$ C to 85 $^{\circ}$ C
Humidity:
10% to 90%, non-condensing

Filament Voltage:

12Vac (dc filament optional)

Filament Current:

5A (up to 12A max available)

Dimensions:

5.25"(3U) H x 19" W x 22" D (13.3cm x 48.3cm x 55.9cm)

Weight:

90lbs (40kg)

Regulatory Approvals:

Compliant to EEC EMC Directive.
Compliant to EEC Low Voltage Directive.

ADDITIONAL FEATURES

Water Flow Switch:

A 24Vdc signal is available on the rear panel to turn on the cooling water to the X-Ray tube. This signal can be enabled either when control power is on or when the high voltage is turned on. (Customer must specify)

Fail Safe Interlock:

A 24Vdc signal is available on the rear panel to energize an external X-Ray on lamp. This signal is energized when the high voltage is turned on. High voltage will not enable if this circuit is open. (A 220Vac signal is optional)

Preheat and Ramp:

Automatic preheat and ramp control circuits are provided which ramp the kV and mA slowly to set levels. kV ramps in approximately 10 seconds while mA ramps in approximately 20 seconds.

Output Connector:

75kV, 3 conductor Federal Standard X-Ray connector. 60kV is connected to terminal "C". Terminals "S" and "L" are jumped together. The filament output is connected between terminals "C" and "S". Other configurations are optional. (On the FF3, all output connections S, L, & C are connected together)

Remote Signal Connector:

Remote interface is available via a 50 pin mini D connector. Extensive remote programming and monitoring is provided.

Electronic Component (Power Source)

DF/FF series is intended for installation as a component of a system. It is designed to meet CE standards, with conditions of acceptance often being: customer provided enclosure mounting, EMC filtering, and appropriate protection, and isolation devices. The DF/FF series is not intended to be operated by end users as a stand-alone device. The DF/FF series power supply can only be fully assessed when installed within a system, and as a component part within that system.

JB1 MINI D CONNECTOR 50 PIN

PIN	SIGNAL
1	+5Vdc (or connect to pin-11)
2	Control Power On
3	Intlk
4	X-Ray On
5	X-Ray Off
6	Spare
7	Spare
8	Reset
9	Rmt/Lcl
10	24V Switched
11	+5Vcch
12	X-Ray On Status
13	Overvoltage
14	kV Min
15	Overpower
16	Filament Current Limit
17	mA Current Limit
18	LCL Status
19	Power Supply Fault
20	Gnd
21	Spare
22	(DF) Remote X-Ray On
23	(DF) Remote X-Ray On Ret
24	Spare
25	Gnd
26	kV Ref
27	kV Com
28	mA Ref
29	mA Com
30	Spare
31	Spare
32	Spare
33	Pwr. Limit (OL Ref)
34	Pwr. Limit Com (OL Com)
35	Filament Current Limit
36	Filament Current Limit Com
37	Spare
38	kV Monitor
39	mA Monitor
40	Spare
41	Spare
42	kV Ref Mon
43	mA Ref Mon
44	Spare
45	Spare
46	Filament Monitor
47	Mon Common
48	Spare
49	Gnd
50	Spare

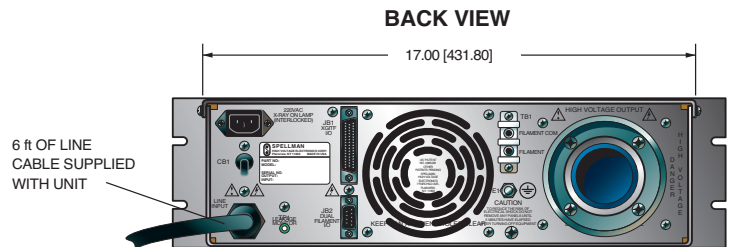
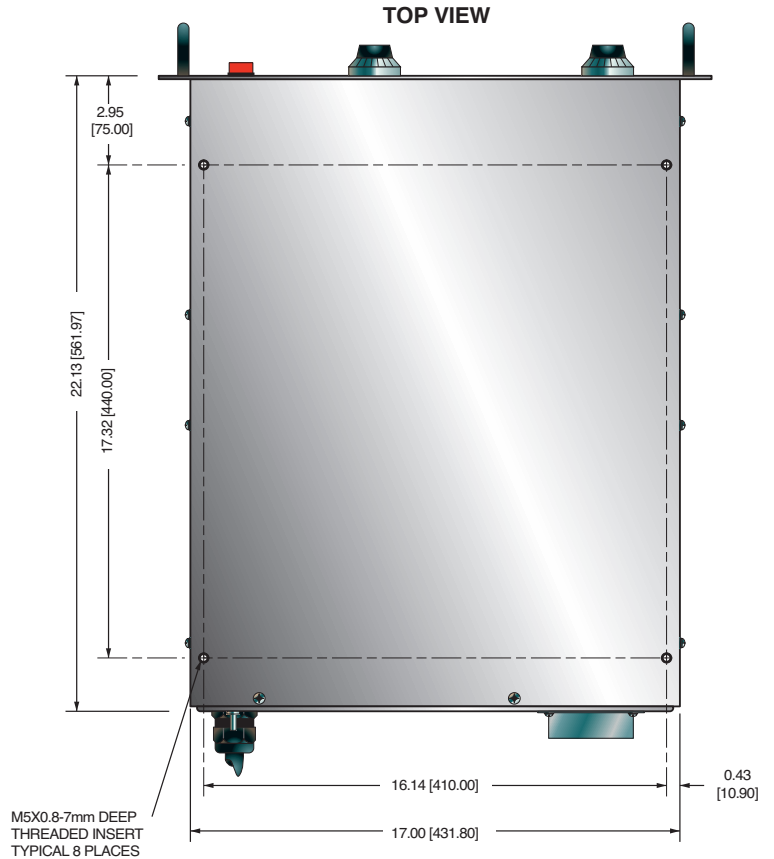
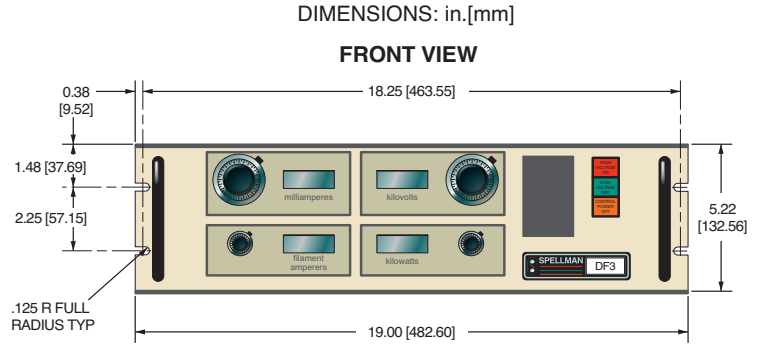

Cost reduced version for OEM quantities available, contact Sales.





- **Custom Designed Specifically for Mammography Applications**
- **Compact Space Saving Modular Format**
- **Fast Settling Helps Minimize Unnecessary Patient Radiation Exposure**
- **Dual Speed Starter, Boost/Brake Capability**
- **RS-232 and Optional Ethernet Interfaces**
- **Low Cost, Value Added Design**

Spellman's VMX redefines the standard for high performance, low cost Mammography X-Ray generators. The VMX was born from an integrated, high performance, value added design perspective so there's no need to compromise critical specifications to meet ever demanding system price targets.

The 40kV/5kW X-Ray generator integrates a dual filament power supply and a dual speed starter. A DC current source filament power supply provides fast rise times with stable and accurate X-Ray tube emission currents. The solid encapsulated high voltage output section eliminates oil concerns while reducing the effects of environmental humidity and contamination.

Flexibility in interfacing is provided via RS-232 and optional Ethernet connectivity. The VMX supports advanced mammography application features including Smart AEC Exposure, Automatic Filament Calibration, Tube Anode Heat Calculator and user configurable Tube Library. Compact, full featured, high performance, low cost. Spellman's VMX, the next generation Mammography X-Ray generator.

SPECIFICATIONS

Input Voltage:

200-240Vac ($\pm 10\%$), single phase, 50Hz/60Hz

Input Current:

Minimum 35A service recommended for 5kW operation
External EMC Filter (Schaffner FN2070-36-08-36A)
required to meet CE/EMC specifications – Not provided with the generator

Mains Contactor – Not provided within the generator.
Customer is responsible for mains safety disconnection.

Output Voltage

Output Voltage Range:

20kV to 40kV

Polarity:

Positive, grounded cathode X-Ray tube

Accuracy:

Within 1% of programmed values

Reproducibility:

<0.5%

Settling Time:

<10ms

Ripple:

$\leq 1\%$

Stability:

$\leq 0.01\%$ per 8 hours

Temperature Coefficient:

$\leq 100\text{ppm}/^\circ\text{C}$

Output Current/Power

Output Current Range:

10mA to 200mA

Output Power:

5kW @ 0.1 second loading time
30W maximum average power

Maximum mAs:

600mAs

Exposure Timer:

5ms-10 seconds

Accuracy:

Within 2% of programmed values measured after mA rises to stable DC level

Reproducibility:

<0.5%

Settling Time:

<10ms

Filament Configuration:

DC filament drive: self corrected filament preheat settings with closed loop emission control and smart learning algorithm

Filament Output:

0-6 amps at a compliance of 5.5 volts, maximum

Dual Speed Starter:

High speed (180Hz) and low speed (60Hz) can be configured via the serial interface.
Boost and Brake capability provided.

High Voltage Connector:

60kV, Claymount CA-3 type or equivalent

Optional Communication Interface:

Ethernet (RJ45)

Grounding Point:

M5 ground stud provided on chassis

Environmental:

Temperature Range:
Operating: 10°C to 40°C
Storage: -40°C to 85°C
Humidity:
20% to 85% RH, non-condensing.

Cooling:

Convection cooled, no internal fans.
Forced air cooling not required

Dimensions:

9.38" H X 6.6" W X 12" D
(237.5mm x 167.6mm x 304.8mm)

Weight:

<22 pounds (10kg)

Regulatory Approvals:

Compliant to EMC:IEC 60601-1-2. UL/CUL recognized file E242584. RoHS compliant.

Application Features:

- 2 point/3 point exposure modes
- AEC/Smart AEC exposure modes
- Automatic filament current calibration
- Tube anode heat calculator
- User configurable tube library

TB2 ROTOR INTERFACE

PIN	SIGNAL	PARAMETERS
TB2-1	PHASE	To tube auxiliary winding
TB2-2	RUN	To tube principle winding
TB2-3	COM	To tube common winding
TB2-4	GROUND	To tube housing ground

TB3 TUBE AND INTERLOCK INTERFACE

PIN	SIGNAL	PARAMETERS
TB3-1	SMALL FIL	Connection to tube small filament
TB3-2	COMMON	Connection to tube filament common
TB3-3	LARGE FIL	Connection to large filament
TB3-4	GROUND	Generator chassis for cable shield connection
TB3-5	Interlock 2+	Used if tube has separate thermostat switch.
TB3-6	Interlock 2-	Open = OVER TEMP. (short terminals if not used)
TB3-7	Interlock 3+	Used if tube has cooling circulator flow switch.
TB3-8	Interlock 3-	Open = NO FLOW. (short terminals if not used)
TB3-9	Safety Interlock+	User signal (Contact Closure) for safety interlocks such as door interlocks. Open turns HV OFF, or inhibits HV from being generated. Closed = OK 24Vdc @ <1A typical
TB3-10	Safety Interlock-	
TB3-11	Contactor Coil+	Option for contactor coil control
TB3-12	Contactor Coil-	
TB3-13	Spare	N/C
TB3-14	Spare	N/C
TB3-15	Tube Current+	Tube current flows out from this pin
TB3-16	Tube Current-	Tube current flows into this pin

VMX STANDARD SYSTEM INTERFACE— JB1 25 PIN MALE D CONNECTOR

PIN	SIGNAL	PARAMETERS
1	GND	Signal Ground
2	+5Vdc Out	+5Vdc, 100mA max.
3	RS-232 Tx Out	RS-232 Transmit
4	RS-232 Rx In	RS-232 Receive
5	PREP	User signal (Contact Closure) to alert the generator that exposure sequence will begin. Once this signal is active, exposure parameters are locked in and cannot be changed. The generator enables the starter to to boost the rotor. Contact connection to pin 24. Closed = PREP, the filament is placed in preheat mode
6	READY	Generator signal to user to indicate the rotor runs to speed and the generator is ready for X-Ray exposure Open Collector. Low/Active = Ready
7	ROTOR SHUTDOWN	User signal to brake the rotor drive
8	EXPOSURE	User signal (Contact Closure) to generator to generate X-Rays. Filament is boosted, and high voltage is generated after the boost time. Contact connection to pin 24. Closed = Exposure
9	X-Ray ON 75% Status	Transistor output to indicate X-Ray ON status synchronized with 75% of kVP setting point.
10	X-Ray ON Status	Transistor output to indicate X-Ray ON status synchronized with kV start up.
11	N/C	N/C
12	X-Ray SHUTDOWN/AEC	User signal to generator to rapidly turn HV OFF and ON during serial exposure sequence
13	RS-232 ISO Ground	Isolated ground from RS-232 transceiver IC
14	HVG FAULT Status	Generator signal indicating generator fault. Open collector transistor output. Low/Active = Fault
15	Status Bit 1	3 bit status lines for up to 6 status messages. See separate matrix describing functionality. Open Collector. Low/Active = Message
16	Status Bit 2	
17	Status Bit 3	
18	N/C	N/C
19	N/C	N/C
20	kV Monitor	Signal from generator. 0-10V = 0-40kV. Zout = 1kΩ
21	Emission Monitor	Signal from generator. 0-10V = 0-200mA. Zout = 1kΩ
22	Filament Current Monitor	Signal from generator. 0-10V = 0-6A. Zout = 1kΩ
23	Program/Monitor Return	Ground for reference of program and monitor signals
24	+24Vdc Out	For connection to PREP and EXPOSURE control relay coils
25	SHIELD/GND	For connection of interface cable shield to generator chassis ground

DIMENSIONS: in.[mm]

FRONT VIEW

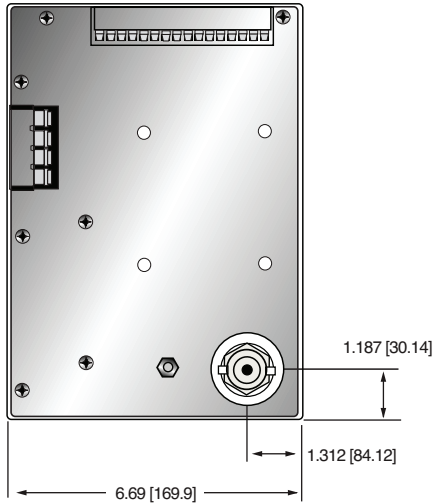

TOP VIEW

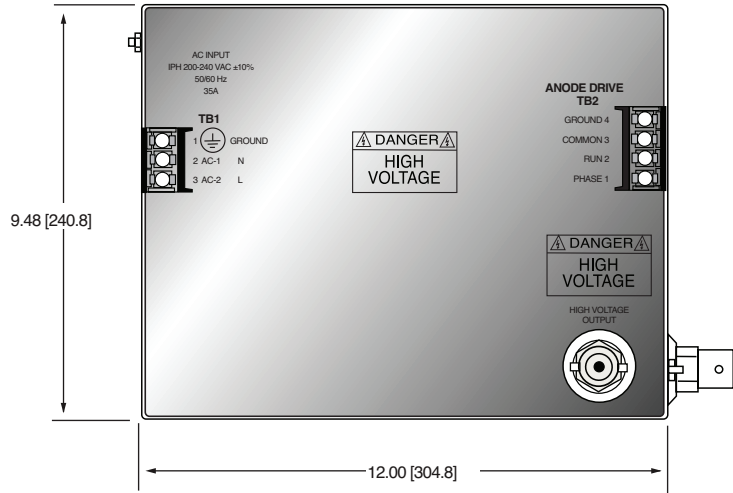

BOTTOM VIEW

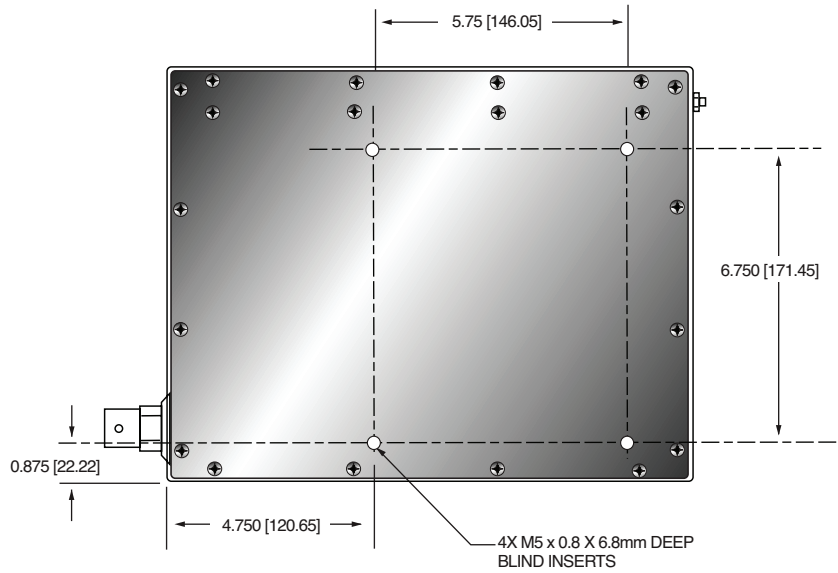

SIDE VIEW

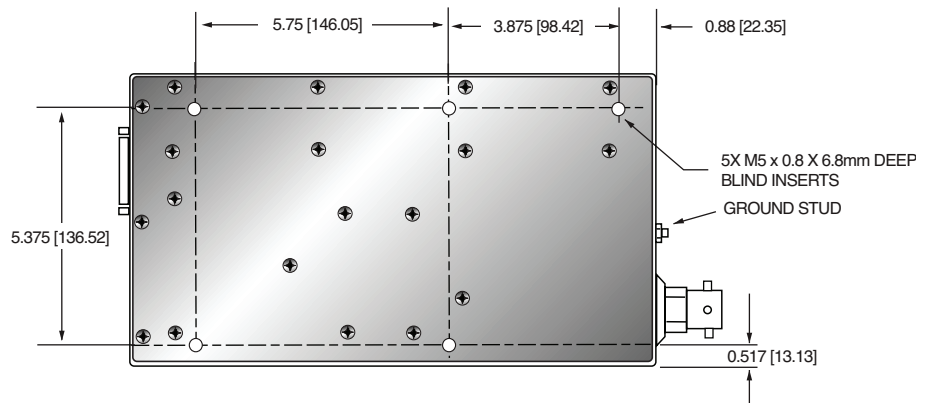



- **Custom Designed Specifically for Mammography Applications**
- **Compact Space Saving Modular Format**
- **Fast Rise and Fall Times Help Minimize Unnecessary Patient Radiation Exposure**
- **Dual Speed Starter, Boost/Brake Capability**
- **RS-232 and Optional Ethernet Interfaces**

Spellman's PMX is a high performance X-Ray generator designed specifically for mammography applications including FFDM and DBT. It features 2 and 3 point exposure modes as well as smart AEC with a pre exposure.

The PMX is a 5kW high frequency X-Ray generator integrated with a dual filament power supply, and a dual speed X-Ray tube starter. Due to the PMX's superior power conversion technology and inverter design it can provide stable and accurate X-Ray tube high voltage with fast rise and fall times.

Smooth system integration of the PMX is accomplished through the use of RS-232 and optional Ethernet digital interface, preloaded X-Ray tube parameters, easy access interlocks and I/O connections, and internal generator diagnostics. Optional GUI utility software is also offered to help with initial system integration.

SPECIFICATIONS

Input Voltage:

200-240Vac ($\pm 10\%$), single phase, 50Hz/60Hz

Input Current:

Minimum 35A service recommended for 5kW operation
 External EMC Filter (Schaffner FN2070-36-08-36A) required to meet CE/EMC specifications – Not provided
 Mains Contactor – Not provided
 Customer is responsible for mains safety disconnection.

Output (Tube) Voltage

Output Voltage Range:

20kV to 49kV

Polarity:

Positive, grounded cathode X-Ray tube

Accuracy:

2% (measured per IEC60601-2-45)

Reproductibility:

<0.5%

Rise Time:

<1ms to within 98% of the programmed voltage

Fall Time:

<10ms with a max HV cable length of 8 feet (2.4 meters)

Ripple:

$\leq 4\%$ p-p

Output (Tube) Current/Power:

Output Current Range:

10mA to 200mA

Output Power:

5kW @ 0.1 second loading time,
 300 Watts maximum average power

Accuracy:

< $\pm 10\%$ on exposure less than 10ms
 (measured per IEC60601-2-45)

Rise Time:

<1ms to within 95% of the programmed mA value

Fall Time:

<10ms with a maximum HV cable length of 8 feet (2.4 meters)

Exposure Time (Loading Time):

Maximum Single Exposure Time:

10 seconds

Shortest Single Exposure Time:

5ms

Loading time accuracy:

$\pm 3\% + 1\text{ms}$ (measured per IEC60601-2-45)

Maximum mAs:

600mAs

Exposure Timer:

5mS-10 seconds

Accuracy:

< $\pm 10\%$ (measured per IEC60601-2-45)

Reproductibility:

<0.5%

Filament Configuration:

DC filament drive: self corrected filament preheat settings with closed loop emission control and smart learning algorithm

Filament Output:

0-6 amps at a compliance of 5.5 volts, maximum.

Dual Speed Starter:

High speed (180Hz) and low speed (60Hz) can be configured via the serial interface.
 Boost and Brake capability provided.

High Voltage Connector:

60kV, Claymount CA-3 type or equivalent

Communication Interface:

RS-232 standard, optional Ethernet

Grounding Point:

M5 ground stud provided on chassis

Environmental:

Temperature Range:
 Operating: 10°C to 40°C
 Storage: -40°C to 85°C

Humidity:
 20% to 85% RH, non-condensing.

Cooling:

Internal fan

Dimensions:

9.47" H X 7.19" W X 13.72" D
 (240.5mm x 182.6mm x 348.5mm)

Weight:

<23 pounds (10.5kg)

Regulatory Approvals:

Designed to meet EMC:IEC 60601-1-2. UL/CUL recognized file E242584. RoHS compliant.

Application Features:

- 2 point/3 point exposure modes
- AEC/Smart AEC exposure modes
- Dual Speed Starter
- X-Ray tube anode heat calculator
- Preloaded X-Ray tube parameters and expandable X-Ray tube library

TB3 TUBE AND INTERLOCK INTERFACE

PIN	SIGNAL	PARAMETERS
TB3-1	SMALL FIL	Connection to tube small filament
TB3-2	COMMON	Connection to tube filament common
TB3-3	LARGE FIL	Connection to large filament
TB3-4	GROUND	Generator chassis for cable shield connection
TB3-5	Interlock 2+	Used if tube has separate thermostat switch.
TB3-6	Interlock 2-	Open = OVER TEMP. (short terminals if not used)
TB3-7	Interlock 3+	Used if tube has cooling circulator flow switch.
TB3-8	Interlock 3-	Open = NO FLOW. (short terminals if not used)
TB3-9	Safety Interlock+	User signal (Contact Closure) for safety interlocks such as door interlocks. Open turns HV OFF, or inhibits HV from being generated. Closed = OK 24Vdc @ <1A typical
TB3-10	Safety Interlock-	
TB3-11	Contactors Coil+	Option for contactor coil control
TB3-12	Contactors Coil-	
TB3-13	Spare	N/C
TB3-14	Spare	N/C
TB3-15	Tube Current+	Tube current flows out from this pin
TB3-16	Tube Current-	Tube current flows into this pin

TB2 ROTOR INTERFACE

PIN	SIGNAL	PARAMETERS
TB2-1	PHASE	To tube auxiliary winding
TB2-2	RUN	To tube principle winding
TB2-3	COM	To tube common winding
TB2-4	GROUND	To tube housing ground

PMX STANDARD SYSTEM INTERFACE – JB1 25 PIN MALE D CONNECTOR

PIN	SIGNAL	PARAMETERS
1	GND	Signal Ground
2	+5Vdc Out	+5Vdc, 100mA max.
3	RS-232 Tx Out	RS-232 Transmit
4	RS-232 Rx In	RS-232 Receive
5	PREP	User signal (Contact Closure) to alert the generator that exposure sequence will begin. Once this signal is active, exposure parameters are locked in and cannot be changed. The generator enables the starter to boost the rotor. Contact connection to pin 24. Closed = PREP, the filament is placed in preheat mode
6	READY	Generator signal to user to indicate the rotor runs to speed and the generator is ready for X-Ray exposure Open Collector. Low/Active = Ready
7	ROTOR SHUTDOWN	User signal to brake the rotor drive
8	EXPOSURE	User signal (Contact Closure) to generator to generate X-Rays. Filament is boosted, and high voltage is generated after the boost time. Contact connection to pin 24. Closed = Exposure
9	X-Ray ON 75% Status	Transistor output to indicate X-Ray ON status synchronized with 75% of kVP setting point.
10	X-Ray ON Status	Transistor output to indicate X-Ray ON status synchronized with kV start up.
11	N/C	N/C
12	X-Ray SHUTDOWN/AEC	User signal to generator to rapidly turn HV OFF and ON during serial exposure sequence
13	RS-232 ISO Ground	Isolated ground from RS-232 transceiver IC
14	HVG FAULT Status	Generator signal indicating generator fault. Open collector transistor output. Low/Active = Fault
15	Status Bit 1	3 bit status lines for up to 6 status messages. See separate matrix describing functionality. Open Collector. Low/Active = Message
16	Status Bit 2	
17	Status Bit 3	
18	N/C	N/C
19	N/C	N/C
20	kV Monitor	Signal from generator. 0-10V = 0-50kV. Zout = 1kΩ
21	Emission Monitor	Signal from generator. 0-10V = 0-200mA. Zout = 1kΩ
22	Filament Current Monitor	Signal from generator. 0-10V = 0-6A. Zout = 1kΩ
23	Program/Monitor Return	Ground for reference of program and monitor signals
24	+24Vdc Out	For connection to PREP and EXPOSURE control relay coils
25	SHIELD/GND	For connection of interface cable shield to generator chassis ground

DIMENSIONS: in.[mm]

FRONT VIEW



SIDE VIEW

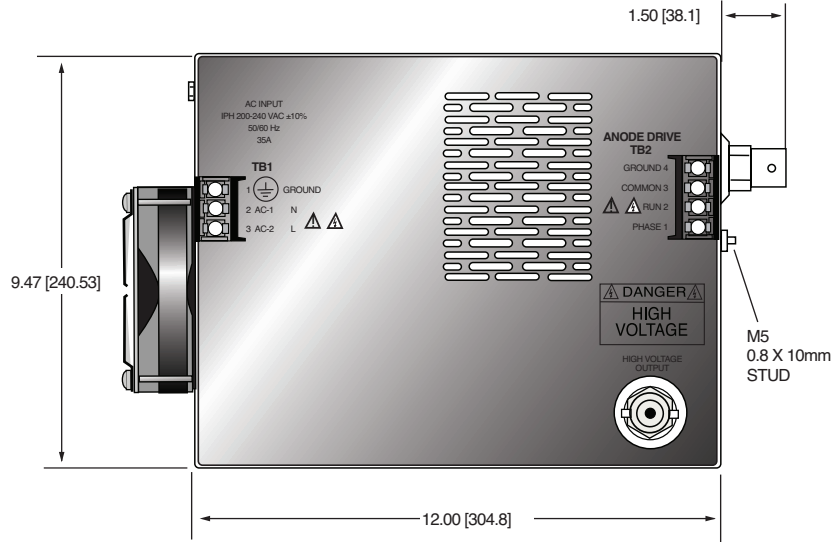

TOP VIEW

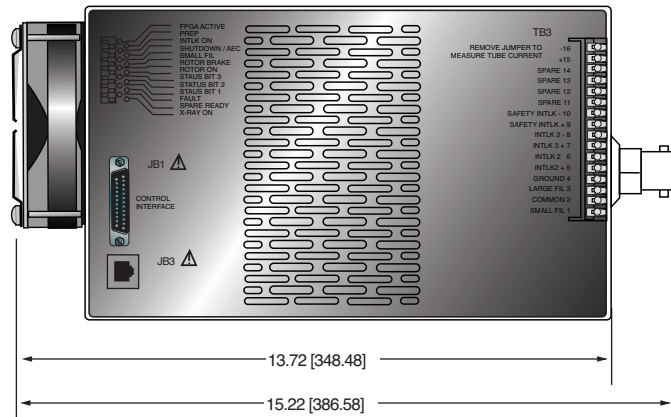

BOTTOM VIEW

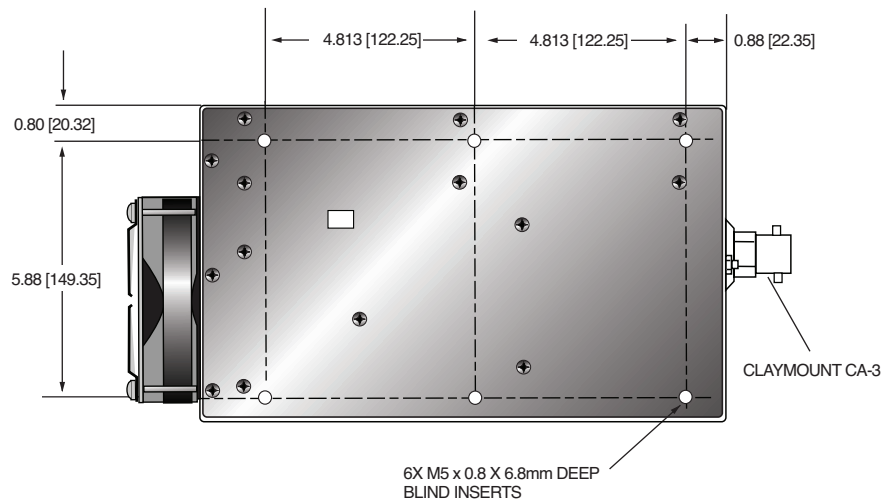

Spellman High Voltage has been designing, manufacturing and providing CT generators for OEM customers for over three decades. We have unrivaled experience being the first provider of a CT generator used in a commercially available continuous rotating CT scanner in 1985. Since then Spellman has enhanced performance and developed new CT generators year after year, setting the standard for CT generator technology.

Spellman High Voltage has manufactured over 30,000 CT generators. We have the knowledge, capability and experience to provide you with the CT generator technology you need.

Ask about our subsystem capabilities

- **CT Generators from 32kW to 110kW**
- **60-140kV output**
- **Rotational CT up to 240rpm**
- **Fast rise time**
- **Designed to drive industry standard CT tubes**
- **Digital interface allows for ease of integration**
- **OEM customization**



32/42/50kW 16-64 slice single chassis "compact" CT generator



50kW/80kW 16-128 slice "performance" CT generator with grid/Z deflection



110kW 64-264 slice "premier" CT generator for state of the art CT systems

MODEL	32/42/50kW Compact CT Generator			50/80kW CT Generator		110kW CT Generator
Model Designation	CCT70PN32	CCT70PN42	CCT70PN50	CT70PN50	CT70PN80	CT140N110
Input Power	400Vac, 3Ø, +15%/-20%, 50/60Hz					
Auxiliary Input Power	220/230Vac, 1Ø +15%/-10%, 50/60Hz			220/230Vac, 1Ø +15%/-10%, 50/60Hz		Not required
kV Output Range	60kV - 140kV (bipolar, 30kV - 70kV)			60kV - 140kV (bipolar, 30kV - 70kV)		60kV to 140kV Anode grounded
kV Output Accuracy	±0.5% of setting					
mA Output Range	10mA - 300mA / 32kW maximum 10mA - 350mA / 42kW maximum 10mA - 360mA / 50kW maximum			10mA - 420mA / 50kW maximum 10mA - 667mA / 80kW maximum		6mA to 900mA, 110kW maximum
mA Regulation/Accuracy	2% or 2mA or which is larger for 20mA -350mA			2% or 1mA or which is larger for 20mA -420mA		2% or 1mA or which is larger for 20mA -900mA
Filament Output	2 outputs: 15Vac @ 0-6A up to 8A available			1 output: 15Vac @ 0-6A, up to 15A available 2 filament/no grid configuration available		2 outputs: 10Vac @ 0-8A,
Filament Accuracy	±5% of setting			±5% of setting		±2% from 25% to 75%, 5% above
Filament Repeatability	±0.2%					
Starter	HSS configured to match X-Ray tube used					
Interface	Custom serial interface					
Rotation	Up to 120 rpm			Up to 120 rpm		Up to 240 rpm
Configuration	Single Chassis			Two chassis		Four chassis
Grid Option	Dual grid/single filament, 0-4kV @ 0-4kHz (separate assembly)			Dual grid/single filament, 0-4kV @ 0-4kHz (built-in)		n/a
Magnetic Z Deflection Option	n/a			Ground based single channel beam steering		n/a

Please consult factory regarding product configuration availability and regulatory requirements for specific markets



- **Constant Potential Output**
- **Excellent Stability and Regulation**
- **Power Factor Corrected AC Input Circuitry**
- **Digital Interface, Ethernet and RS-232**
- **End Grounded Exposed Anode**
- **Portable, Repeatable, Accurate**
- **100% Duty Cycle**
- **Unparalleled Resolution Imaging**
- **Liquid or Air Cooled Models**
- **Penetration of up to 76mm of Fe (300kV unit)**

Spellman's SPX Series are perfectly suited for today's demanding NDT inspection requirements. SPX units are rugged, yet easy to transport and economical to maintain. They can be line or portable generator powered automatically adapting to standard input voltages to permit all day inspection under extreme conditions virtually anywhere.

The end grounded X-Ray tubes have a focal spot size of 1.5mm sq. and the exposed anode allows for easy and flexible positioning of the tube head assembly. Tube ports use a low-absorption beryllium window that allows the radiographer to utilize the full spectrum of X-Ray energy. The high radiation output of the SPX systems allow for lower kV per exposure, shorter exposure times and increased film contrast for superior radiographic imaging.



The SPX microprocessor-driven control unit provides automatic warm-up and comprehensive self-diagnostic circuitry. Memory to store and recall exposure techniques is standard and the last set of exposure parameters is retained before powering down. The SPX is adjustable in 1kV and 0.1mA increments. Exposure duration can be set from 1 second to 99 min 59 seconds in 1 second increments. There are three models to choose from: 160kV, 200kV and 300kV.

TYPICAL APPLICATIONS

- Aerospace
- Manufacturing
- Defense
- Aviation
- Energy
- Security Systems
- NDT Applications

SPECIFICATIONS

Input Line Requirements:

Automatically adapts to input line voltage
 100-130Vac, 50/60Hz, 20 Amperes maximum
 200-250Vac, 50/60Hz, 10 Amperes maximum
 May also be portable-generator powered

X-Ray Output:

SPX160: 10 to 160kV, 0.5mA to 5.0mA (800 watts max.)
 SPX200: 10 to 200kV, 0.5mA to 10.0mA (900 watts max.)
 SPX300: 10 to 300kV, 0.5mA to 10.0mA (900 watts max.)
 Constant potential, end-grounded anode,
 air or liquid cooled versions available

X-Ray Tube Window:

SPX160: Beryllium 0.8mm (directional)
 Nickel 0.6mm (panoramic)
 SPX200: Beryllium 1.0mm
 SPX300: Beryllium 1.0mm

Radiation Coverage:

SPX160: 40° directional or 360° panoramic tube available
 SPX200: 40° directional or 360° panoramic tube available
 SPX300: 40° x 60°

Radiation Output:

SPX160: 14R/min at 50cm filtered with 0.5 inches (12.7mm) aluminum at 160kV, 5mA
 SPX200: 21R/min at 50cm filtered with 0.5 inches (12.7mm) aluminum at 200kV, 4.5mA
 SPX300: 30R/min at 50cm filtered with 0.5 inches (12.7mm) aluminum at 300kV, 3mA

Radiation Leakage:

Less than 2.0 Roentgens per hour at 1 meter from the X-Ray tube target.

Effective Focal Spot:

SPX160:

Standard: 0.03 x 0.04 in. (0.7 x 1.0mm) EN12543
0.02 in. sq. (0.5mm sq.) IEC60336

Panoramic: This tube has a flat target (0 degree) and therefore it is without dimension along the tube axis (other than panoramic tubes with conical targets). The true focal spot on the target can only be estimated by taking two focal spot film exposures in the main beam 90 degrees apart from each other. Due to this no focal spot is inferred.

SPX200:

Standard: 0.031 x 0.047 in. (0.8 x 1.2mm) EN12453
0.060 in. sq. (1.5mm sq.) IEC60336

Panoramic: 0.015 x 0.15 in. (0.4 x 4.0mm) EN12543

SPX300:

Standard: 0.12 in. sq. (3mm sq.) EN12543

Ambient Temp:

100% duty cycle @ 120°F (49°C)

Duty Cycle:

100% - liquid or air cooled

Storage Temp:

-30°F to 160°F (-35°C to 71°C)

Anode Cooling:

Liquid coolant solution closed loop between X-Ray tube anode and cooling unit, or fan forced air cooling.

Liquid Cooling Unit Dimensions:

Please reference dimension drawings

Liquid Cooling Unit Weight:

54lbs. (15.4kg) approx.

Tube Head Dimensions:

Please reference dimension drawings

Tube Head Weight:

SPX160:

Liquid Cooled: 29lbs. (13.15kg)
Air Cooled: 33lbs. (14.97kg)
Panoramic: 29lbs. (13.15kg)

SPX200:

Liquid Cooled: 37lbs. (16.78kg)
Air Cooled: 41lbs. (18.60kg)
Panoramic: 37lbs. (16.78kg)

SPX300:

Liquid Cooled: 98lbs. (44.5kg)
Air Cooled: 105lbs. (47.61kg)

X-Ray Control Unit:

Digital microcomputer based with local control, RS-232 and Ethernet

X-Ray Control Unit Dimensions:

Please reference dimension drawings

X-Ray Control Unit Weight:

26lbs. (11.8kg) approx.

Safety Devices:

- Tubehead Pressure Relief Valve
- Tubehead Thermal Cut-Out
- Tubehead Pressure Gauge
- Tubehead Low Pressure Cut-Out @ 25psi (1.72 Bar)
- Coolant Flow Sensor (liquid cooled only)
- Control Unit Safety Keyswitch
- Microcomputer-based Self Diagnostics
- Continuous Exposure Parameter Display

Standard Accessories:

- Operation manual
- Tubehead carrying case
- Tubehead Cable- 100' with strain relief
- Extra key (1) for Control Unit Safety Lock
- Power cable - 25' with strain relief
- Coolant hose - twin, 50' with self-sealing terminations (liquid cooled only)
- Cooler power cable

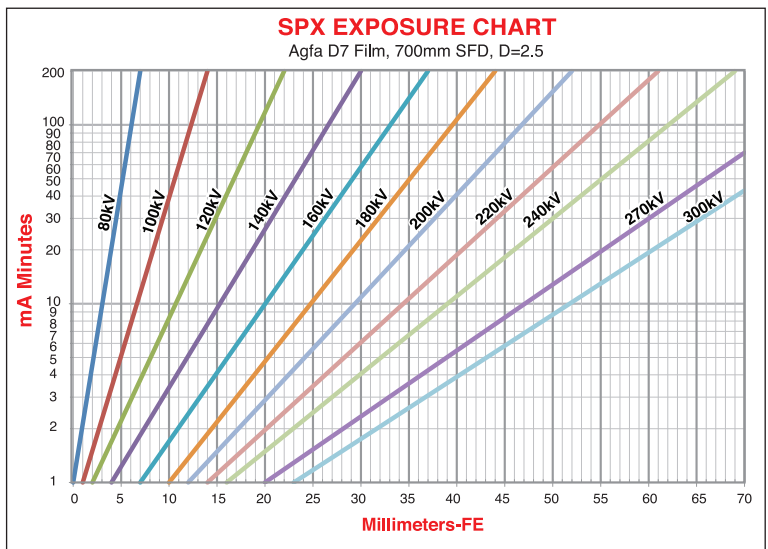

This chart is for reference only (actual settings may vary due to SFD, material, and film type)

SPX160 MODEL SELECTION TABLE

MODEL NUMBER	DESCRIPTION
SPX160ACDBG	Air Cooled, 40° Directional Beam, Glass insert
SPX160LCDBG	Liquid Cooled, 40° Directional Beam, Glass insert
SPX160LCPANG	Liquid Cooled, PANoramic Beam, Glass insert

SPX200 MODEL SELECTION TABLE

MODEL NUMBER	DESCRIPTION
SPX200ACDBC	Air Cooled, 40° Directional Beam, metal Ceramic insert
SPX200LCDBG	Liquid Cooled, 40° Directional Beam, Glass insert
SPX200ACDBG	Air Cooled, 40° Directional Beam, Glass insert
SPX200LCPANC	Liquid Cooled, PANoramic beam, metal Ceramic insert
SPX200LCDBC	Liquid Cooled, 40° Directional Beam, metal Ceramic insert

SPX300 MODEL SELECTION TABLE

MODEL NUMBER	DESCRIPTION
SPX300LCDBC	Liquid Cooled, 40° Directional Beam, metal Ceramic insert
SPX300ACDBC	Air Cooled, 40° Directional Beam, metal Ceramic insert

SPX OPTIONS

MODEL NUMBER	DESCRIPTION
3-000-0754	SPX160/200 tubehead stand
3-000-0756	SPX300 tubehead stand
3-000-0792	Laser pointer for liquid cooled tube
K935	SPX160 Laser pointer for air cooled tube
K936	SPX200 Laser pointer for air cooled tube
K937	SPX200/300 Laser pointer for liquid cooled tube
K938	SPX300 Laser pointer for liquid cooled tube

SPX MAIN AC INPUT

Controller Side; Male, 3 pins MS type

PIN	SIGNAL
A	LINE 1 120/220Vac
B	LINE 2 Neutral 120/220Vac
C	Ground

SPX INTERLOCK CONNECTOR

Controller Side; Female, 7 pins MS type
Tube Side; Male, 7 pins MS type

PIN	SIGNAL
A	External Interlock
B	External Interlock
C	X-Ray ON External Light
D	External Lights Returns (GND)
E	Pre-Warning External Light
F	External Light Confirm
G	24Vac Outut, 1A max.

SPX FAN CONNECTOR (A/C ONLY)

Controller Side; Female, 8 pins MS type
Tube Side; Male, 4 pins MS type

PIN (Control)	PIN (Tube Head)	SIGNAL
D	A	Fan 120Vac Line1
C	B	Fan 220Vac Tap
G	C	Fan 120Vac Line2/Neutral
B	D	Ground
E		N/C
F		N/C
A		Flow Interlock
H		Flow Interlock

SPX COOLER CONNECTOR (W/C ONLY)

Controller Side; Female, 8 pins MS type
Tube Side; Male, 8 pins MS type

PIN	SIGNAL
A	Flow Interlock
B	Ground
C	120/220Vac Line1 for Motor
D	120/220Vac Line2/Neutral for Motor
E	120Vac Motor Tap
F	120/220Vac Motor Tap
G	220Vac Motor Tap
H	Flow Interlock

SPX160 TUBE HEAD CONNECTOR

Controller Side; Female, 10 pins MS type
Tube Side; Male, 10 pins MS type

PIN	SIGNAL
A	Interlock Temperature/Pressure
B	Ground
C	Ground
D	HV Transformer
E	mA Feedback
F	Filament Transformer
G	kV Feedback
H	kV Feedback Return (GND)
I	Filament Transformer
J	HV Transformer

SPX200/300 TUBE HEAD CONNECTOR

Controller Side; Female, 14 pins MS type
Tube Side; Male, 14 pins MS type

PIN	SIGNAL
A	Interlock Temperature/Pressure SPX200, N/C SPX300
B	Ground
C	Ground
D	HV Transformer
E	mA Feedback
F	Filament Transformer
G	kV Feedback
H	kV Feedback Return (GND)
I	Filament Transformer
J	HV Transformer
K	N/C
L	Interlock Temperature/Pressure SPX300, N/C SPX200
M	N/C
N	N/C

OPTIONAL ACCESSORIES

GUI Control Software for the SPX

GUI is specifically designed for controlling SPX series systems. As an alternative to the front panel control, the GUI will allow the user to control all necessary functions of the system from a user-friendly windows based menu. Additionally the GUI can be used as a diagnostic tool when the system is controlled via the front panel.

- **Automatic warm-up of the X-Ray tube**
- **Timed or Continuous Exposure modes**
- **Fault and status monitor**



Laser Pointer

Spellman's exclusive Laser Pointer allows pinpoint image area targeting. The Laser Pointer projects a highly visible reference laser beam from the tubehead to surfaces up to 75 feet away, showing precisely where the central X-Ray beam will be located, providing unmatched accuracy for greater efficiency and reduced set-up times.



Tubehead Stand

An optional X-Ray Tubehead Stand allows for quick set up and provides rigid support for optimal image quality with three-axis positioning of the tube head assembly. The stand incorporates telescoping legs, a hand wheel-driven variable height adjustment and lockable hand wheel controlling the tubehead tilt and horizontal rotation. The tubehead cradle is cushioned for secure mounting and vibration damping. A bubble-type indicator is included for quick and easy leveling of the tubehead. Black anodized aluminum construction. 35lbs. (16kg) approx.



Air Cooled Tube Head Assembly

The air cooled tube head assembly uses a heat sink and high volume fan to dissipate heat from the anode and typically is used in applications that do not have limited access and are not in a volatile fuel vapor atmosphere. The air cooled tube head assembly does not require the cooler unit and the associated mixing and maintenance of liquid coolant. This unit requires less user maintenance and could be considered more environmentally friendly.



Panoramic Tube Head Assembly

The panoramic tube head assembly comes in a liquid cooled version only and produces radiation in a 360 degree cone making it ideal for aircraft FOD inspection, inspection of tanks or pipes or any application that requires circumferential radiographic inspection.



SPX160

DIMENSIONS: in.[mm]

**CONTROL UNIT
TOP VIEW**

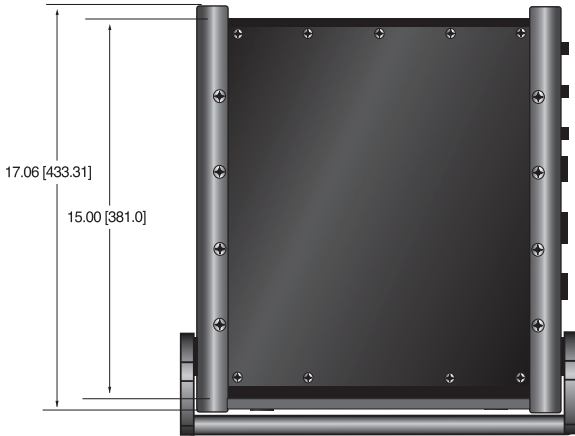

**COOLER
TOP VIEW**

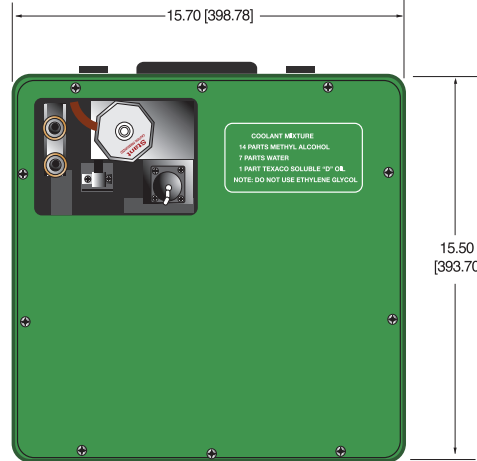

**SPX160
TUBE HEAD
SIDE VIEW**

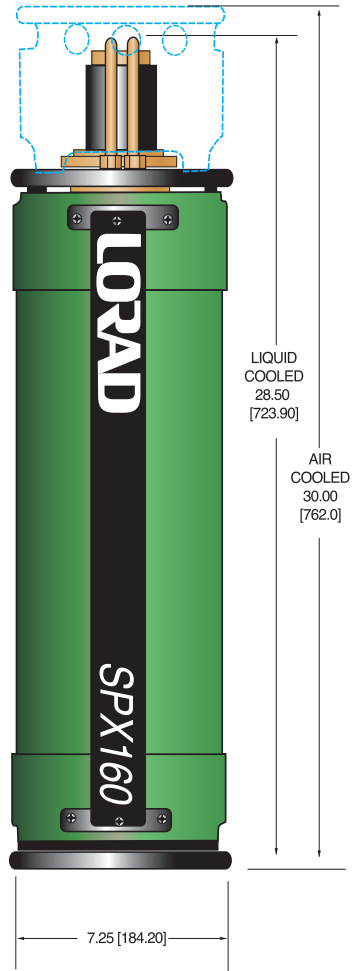

FRONT VIEW

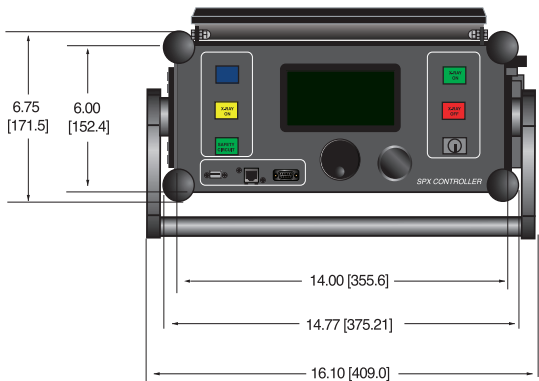

FRONT VIEW

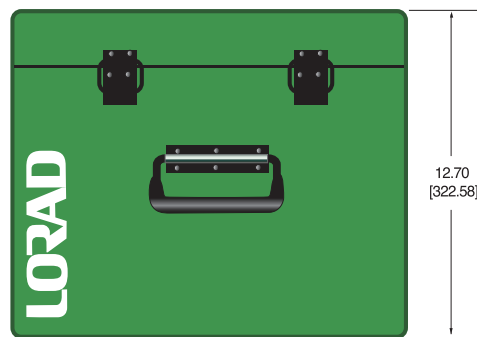

SIDE VIEW

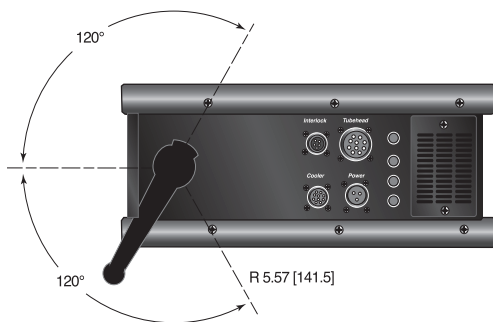

SIDE VIEW

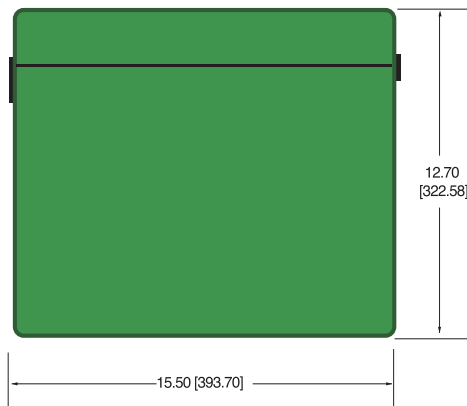

SPX200

DIMENSIONS: in.[mm]

**CONTROL UNIT
TOP VIEW**

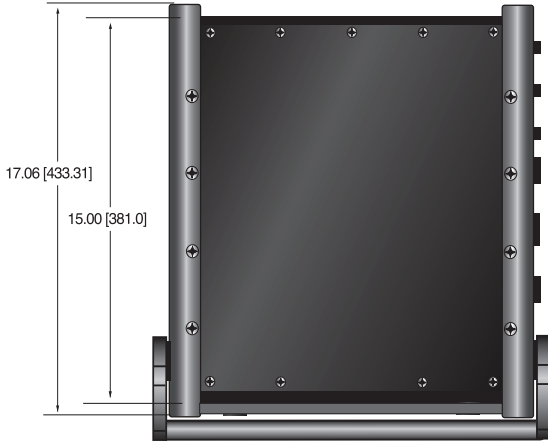

**COOLER
TOP VIEW**

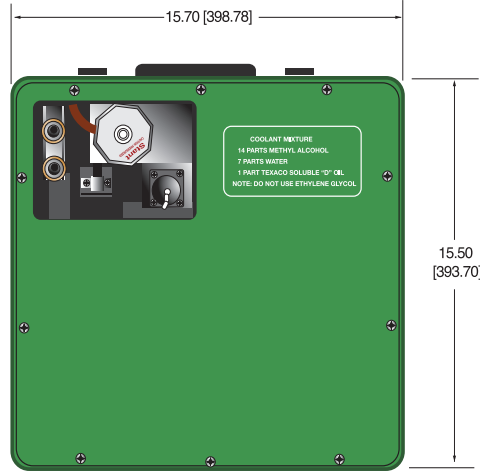

**SPX200
TUBE HEAD
SIDE VIEW**

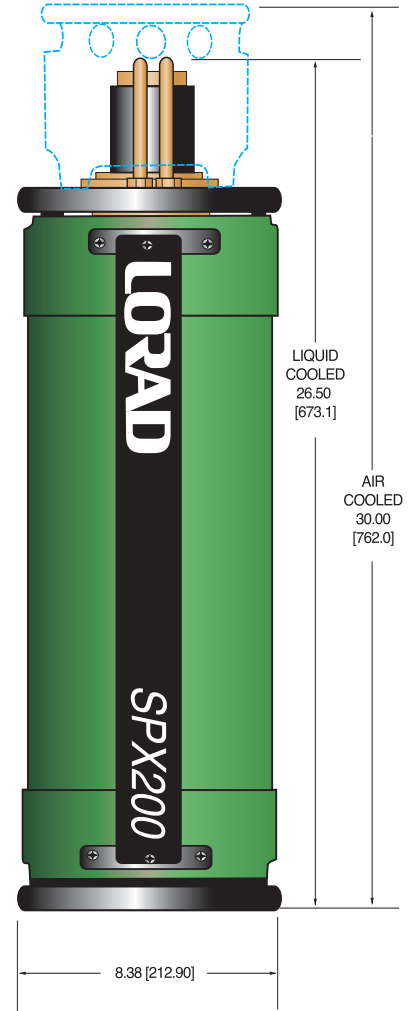

FRONT VIEW

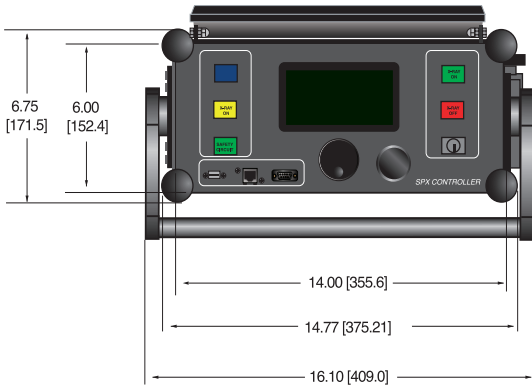

FRONT VIEW

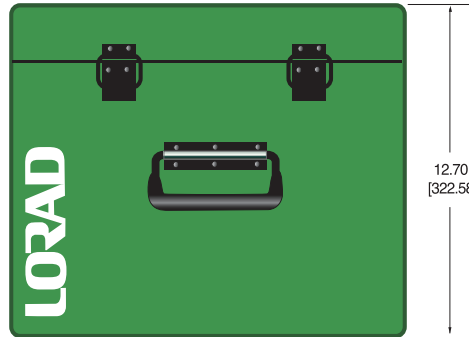

SIDE VIEW

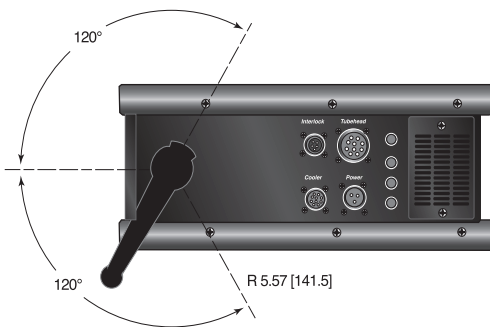

SIDE VIEW

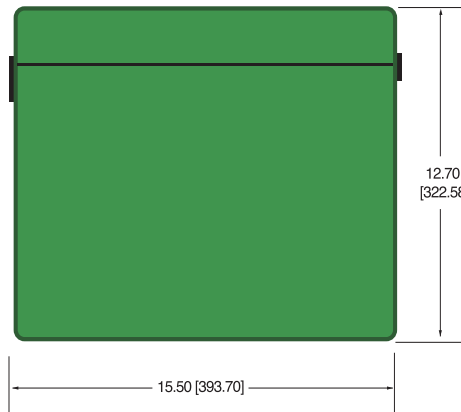

SPX300

DIMENSIONS: in.[mm]

**CONTROL UNIT
TOP VIEW**

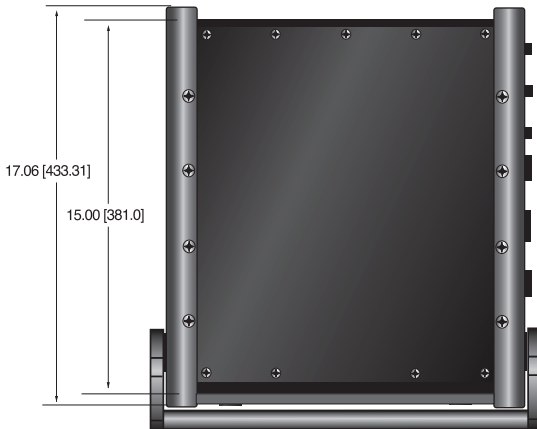

**COOLER
TOP VIEW**

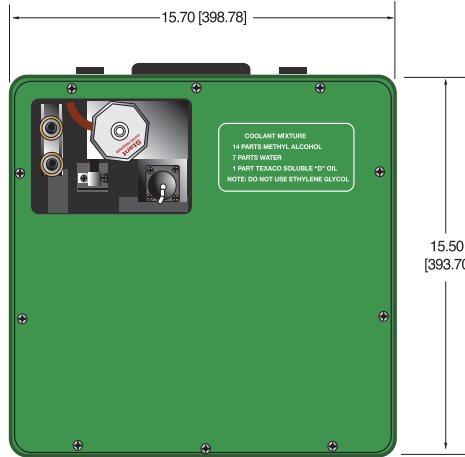

**SPX300
TUBE HEAD
SIDE VIEW**

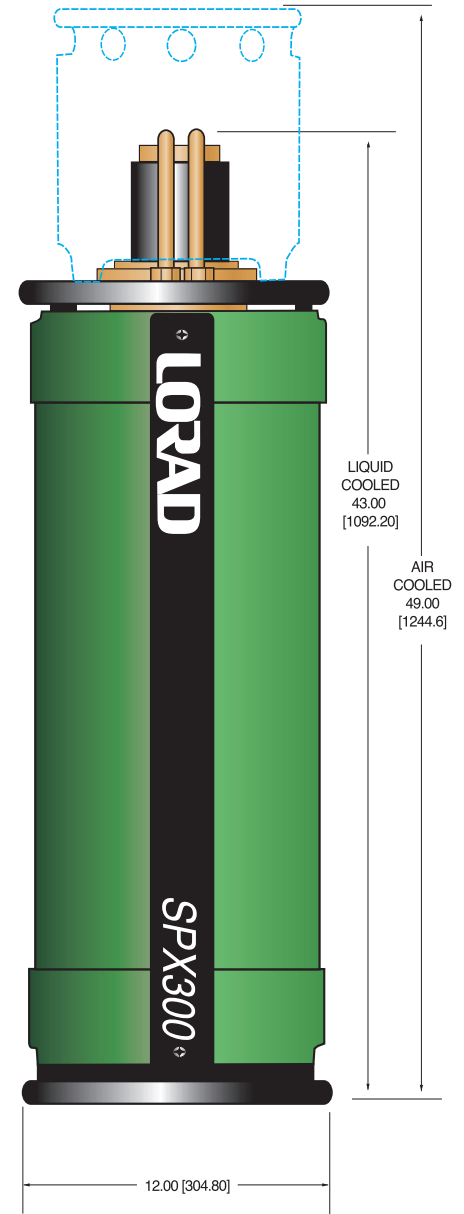

FRONT VIEW

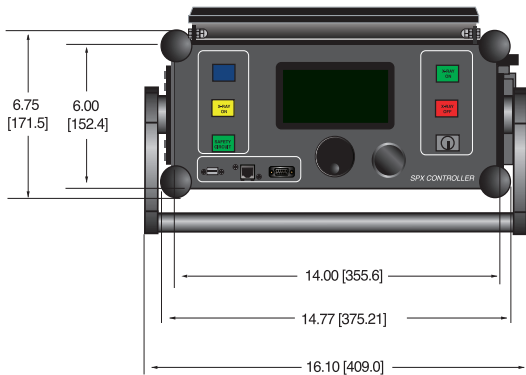

FRONT VIEW

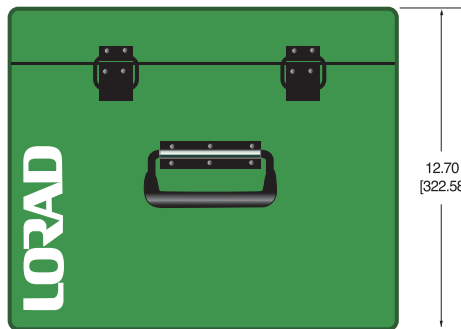

SIDE VIEW

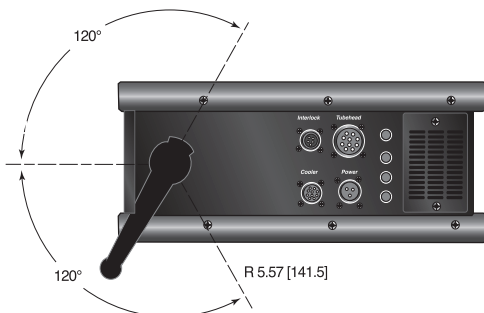

SIDE VIEW

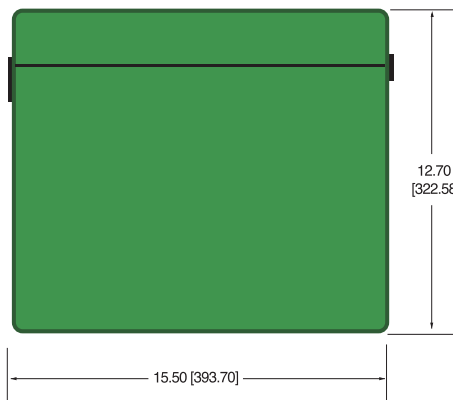



Spellman's LPX Series are perfectly suited for today's demanding NDT inspection requirements. LPX units are rugged, easy to transport and the optional LPX1620 Tubehead Stand allows for quick set up and provides rigid support for optimal image quality. The tubehead stand incorporates telescoping legs, a hand wheel-driven variable height adjustment and lockable hand wheel controlling the tubehead tilt and horizontal rotation. The tubehead cradle is cushioned for secure mounting and vibration damping. A bubble-type indicator is included for quick and easy leveling of the tubehead.

SPECIFICATIONS

Horizontal Rotation:

360°

Tilt:

-45° to +90°

Dimensions:

Footprint of legs:

43" (109cm) min., 70.5" (179cm) max.

Floor to center line of tubehead ring:

45.5" (115cm) min., 83.5" (212cm) max.

Weight:

35lbs. (16kg)

SET-UP

1. Extend tripod legs outward
2. Loosen height lock knob and raise gearhead mount approx. 3 inches
3. Place gearhead on tripod shaft. Align set screw hole in shaft with hole in gearhead mount. Using supplied hex key, tighten set screw to engage gear head mount.
4. Mount tubehead in cradle. Open knurled latch and outer ring to remove cradle assembly. Release the two hook latches on the cradle to open it. Fit cradle over tubehead making sure any cooling manifolds are positioned between cushioning pads. Latch the hook latches securely.
5. Mount cradle in the gear head outer ring. Close and latch the knurled knob locking mechanism.
6. Use the height, tilt, and rotation controls to position the X-Ray tubehead as needed. Lock all adjustments before making X-Ray exposures.



The LPX1620 Tubehead Stand is compatible with all LPX160, LPX200 and LPX300 tubehead assemblies

LPX1620 MODEL SELECTION TABLE

PART NUMBER	DESCRIPTION
3-000-0754	Tubehead stand for LPX160 and LPX200
3-000-0756	Tubehead stand for LPX300

DIMENSIONS: in. [cm]

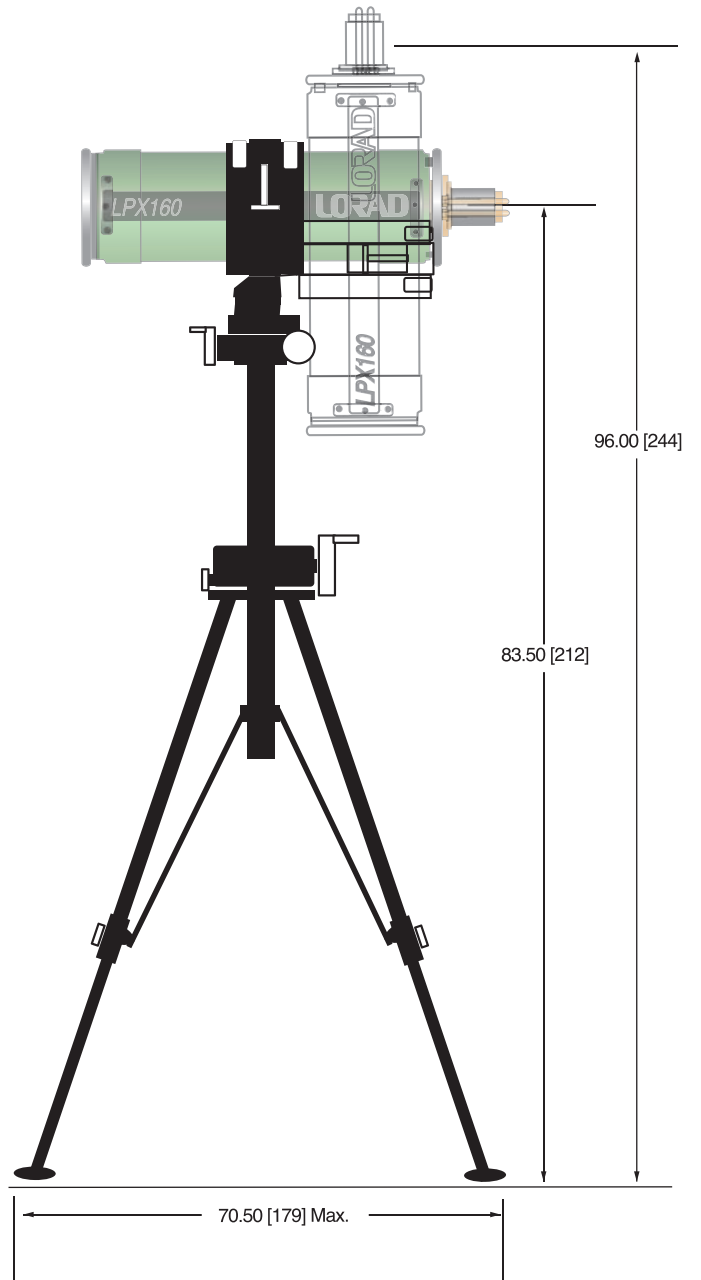
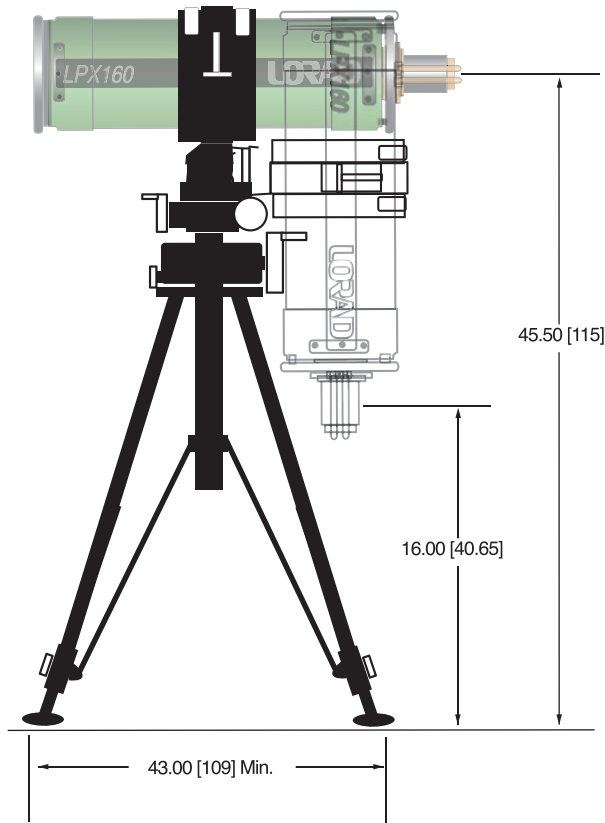
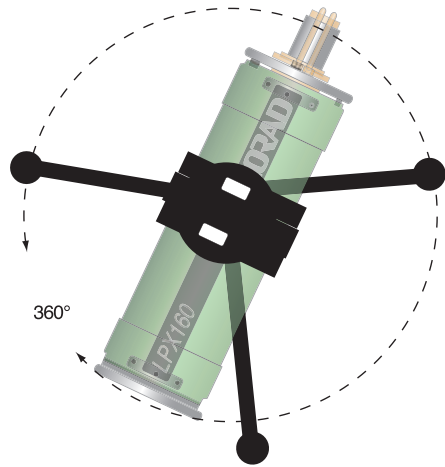



Other imaging systems may produce inconsistent results and require repeat exposures. Spellman's Laser Pointer, exclusive to Lorad's LPX Systems, locates the centerline of the X-Ray beam for unmatched accuracy and efficiency. The Laser Pointer shows precisely where the central X-Ray beam will contact the test area by projecting a highly visible reference beam from the X-Ray tube head to surfaces up to 75 feet away. The beam is activated by a push button and automatically shuts off after 30 seconds. The Laser Pointer is lightweight and powered by three (3) AAA batteries. The Laser Pointer can be used with Lorad's end-grounded exposed anode tube heads and also with air cooled tube heads with the addition of the air cooled adaptor.

SPECIFICATIONS

Wavelength:

670nm typical

Output power:

4.2mW +/-5%

Laser Class:

Class IIIa Conforming (CDRH 21CFR)
Class 3R (IEC 60825 1)

Operating Current:

@ 5Vdc 45mA typical, 125mA max

Battery Lifetime:

20 hours typical (Alkaline AAA cells)

Operating Temp:

10°C to +40°C

Operating time w/o restart:

30 seconds

Dimensions:

1.75" H x 2.72" W x 2.72" D
(4.44cm x 6.90cm x 6.90cm)

- **Exclusive to Lorad LPX Systems**
- **Quick Set Up**
- **Accurate up to 75 Feet Away**
- **Adaptors for Most LPX Tubeheads**

Adaptors:

LPX160 A/C Part Number 9-200-0110
LPX160 L/C N/A
LPX160 Panoramic N/A
LPX200 A/C Part Number 9-200-0327
LPX200 L/C Part number 9-200-0370
LPX200 Panoramic N/A
LPX300 L/C 9-200-0465



The LPX Laser Pointer is compatible with most LPX160, LPX200 and LPX300 tubehead assemblies



- **Integrated HV Supply, Filament Supply, X-Ray Tube, Beam Port and Control Electronics**
- **Compact & Lightweight**
- **Can be Mounted in Any Physical Orientation**
- **Analog or Digital Control Interface**

Spellman's XRB011 Series of Monoblock® X-Ray sources are designed for OEM applications powering its internal X-Ray tube up to 80kV at 20W and 80kV at 50W. Features like 24Vdc input voltage, small package size, standard analog interface and RS-232/Ethernet digital interface simplify integrating the XRB011 into your X-Ray system. Proprietary emission control circuitry provides excellent regulation of X-Ray tube current, along with outstanding stability and performance.

TYPICAL APPLICATIONS

Medical X-Ray: Fluoroscopy and Radiography for Extremities, Specimen Radiography. Pulsed Fluoroscopy (contact Spellman sales)
Industrial X-Ray: Component inspection and Non-Destructive Testing

SPECIFICATIONS

X-Ray Characteristics:

Tube Type: Micro focus tube
Focal Spot: 33µm Nominal, 50µm max. (IEC 336)
Beam Filter: Ultem 0.060" (1.5mm)
Oil 0.175" (4.4mm)
Beam Geometry: Symmetrical 40° cone

Input Voltage:

20W: 24Vdc ±1V @ 2.5A
50W: 24Vdc ±1V @ 4A

X-Ray Tube Voltage:

Nominal X-Ray tube voltage is adjustable between 35kV to 80kV

X-Ray Tube Current:

20W: 0-250µA over specified tube voltage range
50W: 0-700µA over specified tube voltage range

X-Ray Tube Power:

20/50W maximum continuous

Voltage Regulation:

Line: ±0.5% for a ±1V change of nominal input line voltage
Load: ±0.1% for a load change of 25µA to maximum rated current

Voltage Accuracy:

Voltage measured across the X-Ray tube is within ±1% of the programmed value

Voltage Risetime:

Ramp time shall be ≤250ms from 10% to 90% of maximum rated output voltage

Voltage Temperature Coefficient:

≤100ppm/°C

Temperature Stability:

≤.01% per 8 hours after a 1/2 hour warmup

Over Temperature Fault:

Indicates that the internal oil temperature has exceeded 65° C. The high voltage output will be disabled. Toggling the X-Ray ON Command OFF and ON will reset the fault.

Over Voltage Fault:

An overvoltage (OV) fault is detected when the output voltage exceeds 82kV. The high voltage output will be disabled. Toggling the X-Ray ON Command OFF and ON will reset the fault.

Voltage Ripple:

1% peak to peak

Current Regulation:

Line: ±0.5% for a ±1V change of nominal input line voltage
Load: ±0.5% for a voltage change of 35kV to 80kV

Current Accuracy:

Current measured through the X-Ray tube is within ±2.5% of the programmed value

Over Current Fault:

An overcurrent (OC) fault is detected when the emission current exceeds 275µA (20W model) and 710µA (50W model). Toggling the X-Ray ON Command OFF and ON will reset the fault.

Arc Intervention:

One arc fault. The high voltage output will be disabled. Toggling the X-Ray ON command OFF and ON will reset the fault.

Filament Configuration:

Internal high frequency AC filament drive with closed loop filament emission control

Analog Interface:

Ground referenced 10kV/V, 25µA/V (20W model) and 70µA/V (50W model) for programming and monitoring analog interface signals. Open collector, active low digital signal interface. Internal jumper is needed to be configured for analog interface.

Digital Interface:

RS-232: standard
Ethernet: optional

Control Software:

A demo GUI is available for engineering evaluations

Interlock/Signals:

A hardware interlock functions in both analog and digital programming modes.

Operating Temperature:

0°C to +40°C

Storage Temperature:

-20°C to +70°C

Humidity:

10% to 95% relative humidity, non-condensing

Cooling:

50W option: Customer provided, external cooling fan, 50cfm, minimum

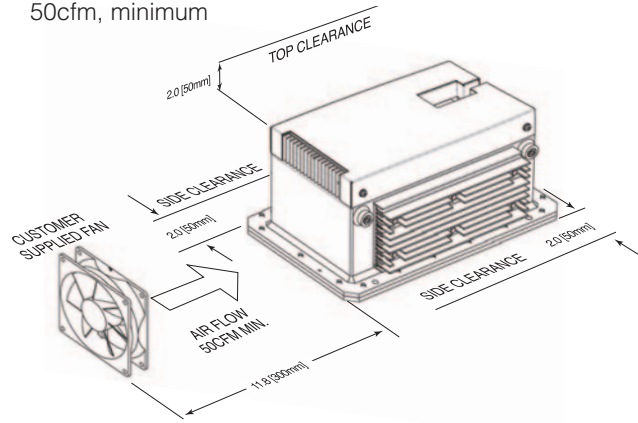

Analog Interface and Input Line Connector:

25 pin D connector, male

Digital Interface Connector:

RS-232: 9 pin D connector, female
Ethernet: RJ45 connector

Grounding Point:

6-32 ground stud provided on chassis

Dimensions:

20W: 5.81"W x 5.0"H x 10.81"D
(147.57mm X 127mm X 274.57mm)
50W: 6.00"W x 5.0"H x 10.81"D
(152.4mm x 127mm x 274.57mm)

Weight:

20W: 18lbs (8.165kg)
50W: 20lbs (9.072kg)

Orientation:

Can be mounted in any orientation.

X-Ray Leakage:

Less than 1mR/hr at 1 meter

Regulatory Approvals:

Compliant to EMC 60601-1-2. UL/CUL recognized file E242584. CE to EN 61010-1 for Non-Medical Applications.

**RS-232 DIGITAL INTERFACE—
J5 9 PIN FEMALE D CONNECTOR**

PIN	SIGNAL	PARAMETERS
1	NC	No Connection
2	TX Out	Transmit Data
3	RX In	Receive Data
4	NC	No Connection
5	SGND	Signal Ground
6	NC	No Connection
7	NC	No Connection
8	NC	No Connection
9	NC	No Connection

**ETHERNET DIGITAL INTERFACE—
RJ45 8 PIN CONNECTOR**

PIN	SIGNAL	PARAMETERS
1	TX +	Transmit Data +
2	TX -	Transmit Data -
3	RX +	Receive Data +
4	NC	No Connection
5	NC	No Connection
6	RX -	Receive Data -
7	NC	No Connection
8	NC	No Connection

**ANALOG INTERFACE—
J1 25 PIN MALE D CONNECTOR**

PIN	SIGNAL	PARAMETERS
1	+24V	+24Vdc±1Vdc @ 4A
2	+24V	+24Vdc±1Vdc @ 4A
3	+24V	+24Vdc±1Vdc @ 4A
4	NC	No Connection
5	+24V RETURN	+24V RETURN
6	+24V RETURN	+24V RETURN
7	+24V RETURN	+24V RETURN
8	Signal Ground	Signal Ground
9	Interlock Input	Input, Active low, Interlock is low safe to enable high voltage. Connect to +24V Return
10	kV Monitor	Output, 0 to 8V = 0 to rated output voltage. Zout=100Ω
11	µA Monitor	Output, 0 to 10V = 0 to rated output current. Zout=100Ω
12	X-Ray Ready status	Output, Active Low, Open Collector, 24Vdc @ 10mA max
13	X-Ray ON status	Output, Active Low, Open Collector, 24Vdc @ 10mA max
14	Filament Standby status	Output, Active Low, Open Collector, 24Vdc @ 10mA max
15	Over Voltage Fault	Output, Active Low, Open Collector, 24Vdc @ 10mA max
16	Over Current Fault	Output, Active Low, Open Collector, 24Vdc @ 10mA max
17	ARC Fault	Output, Active Low, Open Collector, 24Vdc @ 10mA max
18	Filament Current Limit Fault	Output, Active Low, Open Collector, 24Vdc @ 10mA max
19	Signal Ground	Signal Ground
20	Interlock Output	Output, Active Low, Open Collector, 24Vdc @ 10mA max
21	µA Program	Input, 0 to 10V = 0 to rated output current. Zin=10kΩ
22	kV Program	Input, 0 to 8V = 0 to rated output voltage. Zin=10kΩ
23	X-Ray ON Command	Input, Active low Low (short) = X-Ray ON High (open) = X-Ray OFF Internal pull up resistor to +15V
24	Signal Ground	Signal Ground
25	Over Temperature	Output, Active Low, Open Collector, 24Vdc @ 10mA max

20W Model
ORDERING INFORMATION

XRB011-80PN20	80kV, 250uA, 20W, Analog Interface, RS-232
XRB011-80PN20E	80kV, 250uA, 20W, Analog Interface, RS-232, Ethernet
XRB011-80PN20A	80kV, 250uA, 20W, Analog Interface
XRB011-80PN20/CE	80kV, 250uA, 20W, Analog Interface, RS232, CE
XRB011-80PN20E/CE	80kV, 250uA, 20W, Analog Interface, RS232, Ethernet, CE
XRB011-80PN20A/CE	80kV, 250uA, 20W, Analog Interface, CE

XRB011
20W Model

DIMENSIONS: in.[mm]

FRONT VIEW

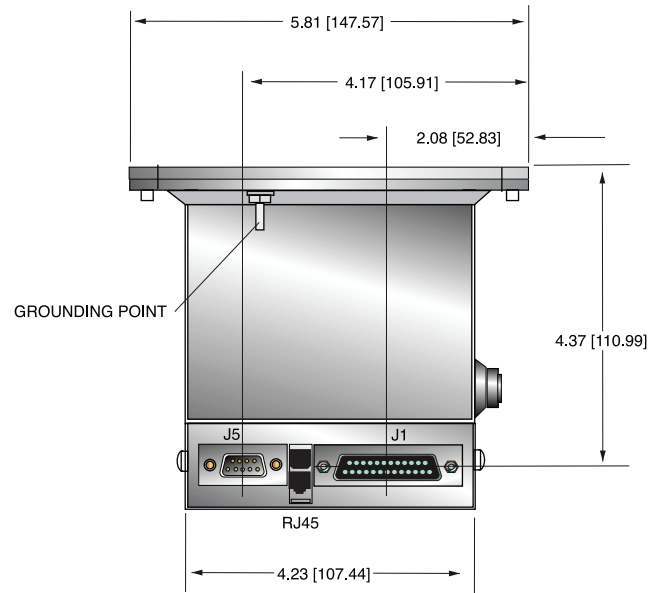

SIDE VIEW

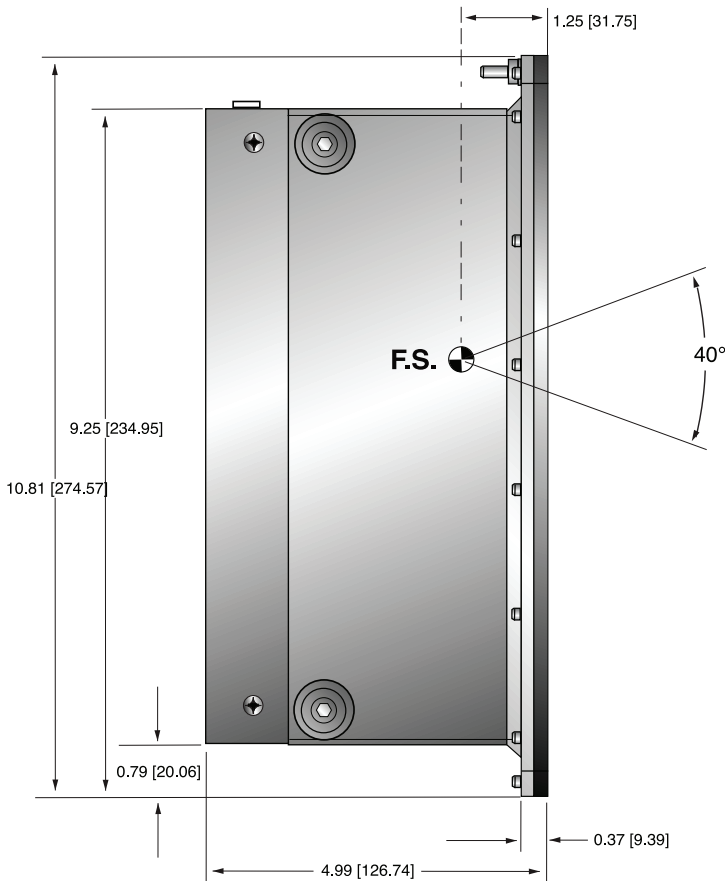

TOP VIEW

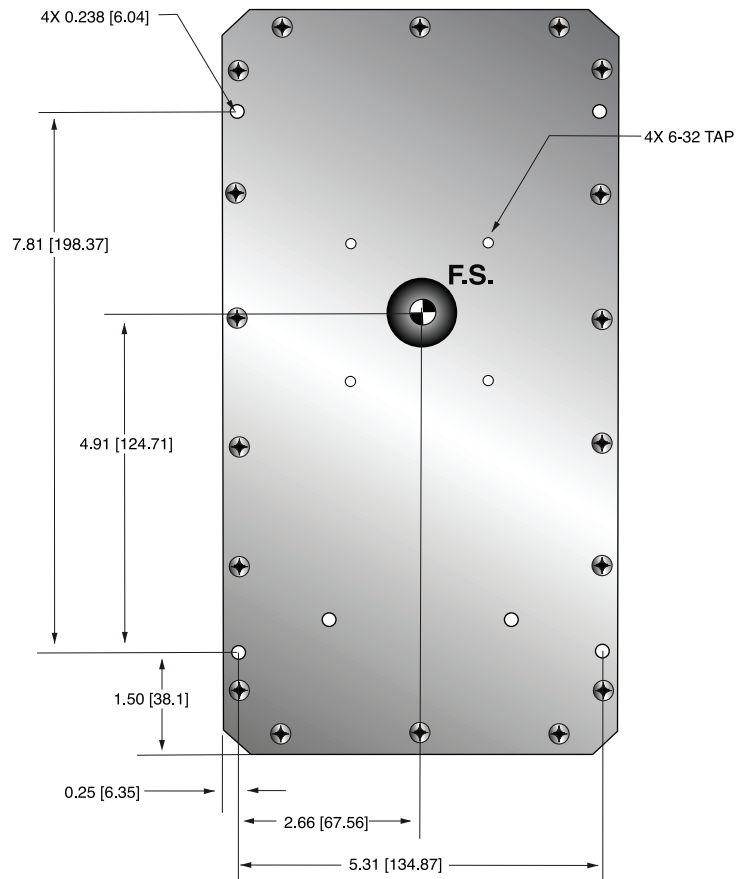

50W Model ORDERING INFORMATION

XRB011-80PN50	80kV, 700uA, 50W, Analog Interface, RS-232
XRB011-80PN50E	80kV, 700uA, 50W, Analog Interface, RS-232, Ethernet
XRB011-80PN50A	80kV, 700uA, 50W, Analog Interface
XRB011-80PN50/CE	80kV, 700uA, 50W, Analog Interface, RS232, CE
XRB011-80PN50E/CE	80kV, 700uA, 50W, Analog Interface, RS232, Ethernet, CE
XRB011-80PN50A/CE	80kV, 700uA, 50W, Analog Interface, CE

XRB011 50W Model

DIMENSIONS: in.[mm]

SIDE VIEW

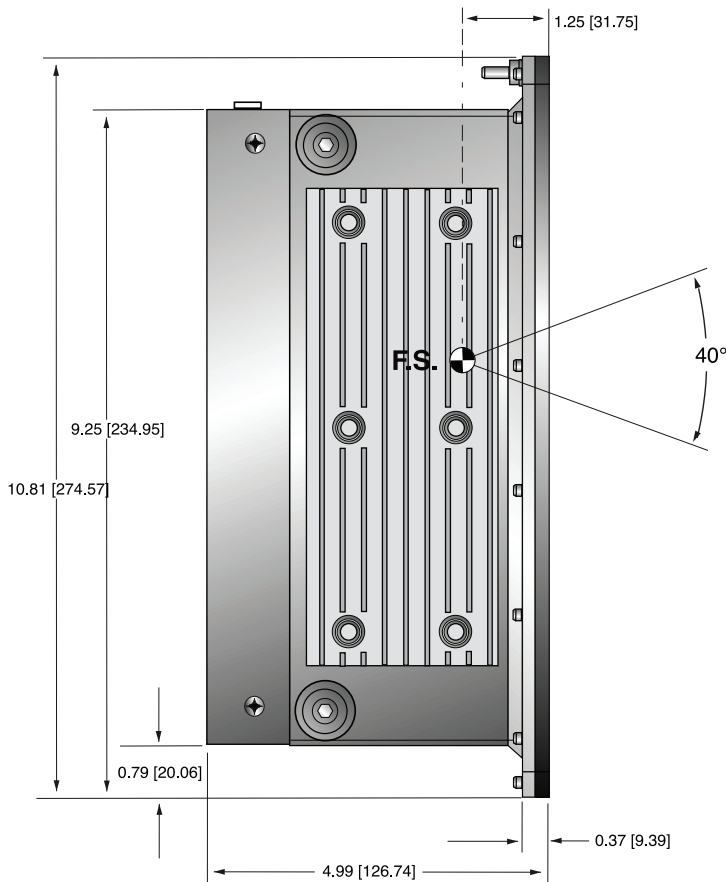

FRONT VIEW

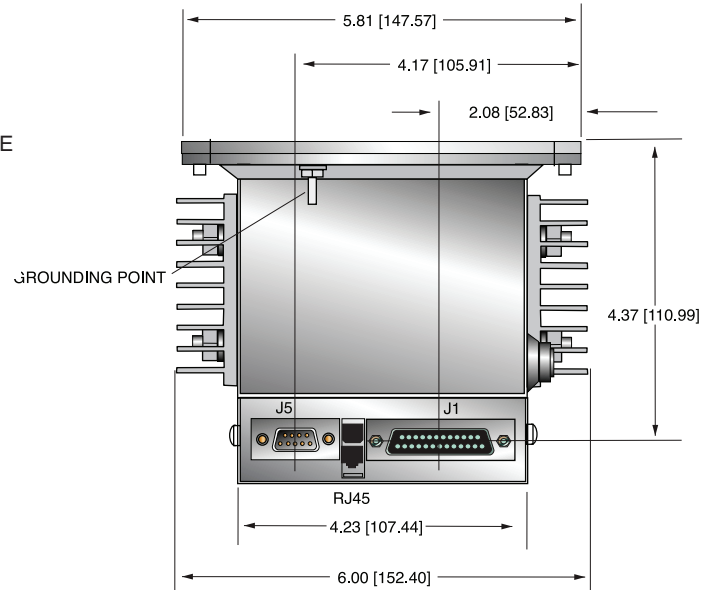

TOP VIEW

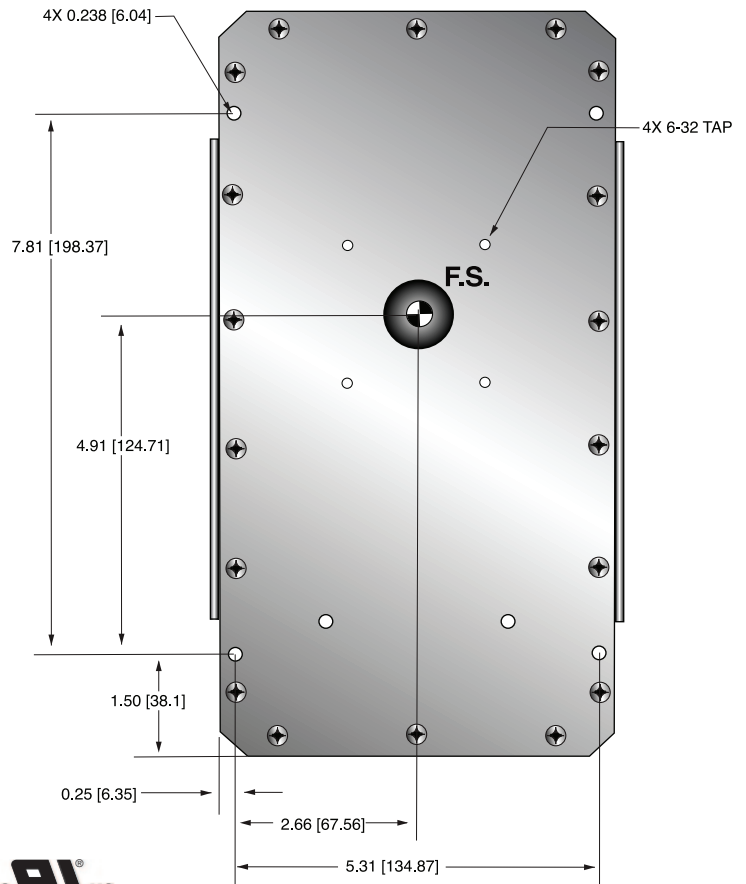



Spellman's XRB80N100 Monoblock® X-Ray source is designed for OEM applications powering its internal X-Ray tube up to 80kV at 100W. Features like universal input, small package size and a standard analog and RS-232 digital interface simplify integrating this unit into your X-Ray system. The XRB80N100 is available either with fan shaped (standard) or (optional) cone shaped beam geometries. Proprietary emission control circuitry provides excellent regulation of X-Ray tube current, along with outstanding stability performance.

TYPICAL APPLICATIONS

X-Ray Scanning: Bone Densitometry, Thickness Measurement, Food Inspection, Fill Level Confirmation, Parcel Inspection

SPECIFICATIONS

X-Ray Characteristics:

Focal Spot: 0.5mm (IEC 336)

Beam Filter:

Ultem: 3.30mm ±0.15mm

Oil: 8mm ±0.1mm

Glass: 1.8mm ±0.25mm

BE: 0.8mm

Beam Geometry:

Fan: Standard. The beam angular coverage will be 75° with the beam plane perpendicular to the X-Ray tube axis and 13° wide.

Cone: Optional. 25° cone beam

Input Voltage:

Power factor corrected input 0.98, 100-240Vac ±10% 50/60Hz, 2A, maximum

X-Ray Tube Voltage:

Nominal X-Ray tube voltage is adjustable up to 80kV

X-Ray Tube Current:

150uA to 1.25mA over specified tube voltage range

X-Ray Tube Power:

100W maximum continuous

- **Integrated HV Supply, Filament Supply, X-Ray Tube, Beam Port and Control Electronics**
- **Compact & Lightweight**
- **Universal Input, Power Factor Corrected with Internal EMI Filter**
- **Can be Mounted in Any Physical Orientation**
- **Analog Control Interface and Standard RS-232 Digital Interface**

www.spellmanhv.com/manuals/XRB80

Voltage Regulation:

Line: ±0.05% of maximum output voltage over a ±10% change of nominal input line voltage

Load: ±0.1% of maximum rated voltage for 150uA to 1.25mA load change

Voltage Accuracy:

Voltage measured across the X-Ray tube is within ±2% of the programmed value

Voltage Risetime:

Standard: Ramp time shall be 500ms from 10% to 90% of maximum rated output voltage

Optional: 5 seconds. Specify at time of order

Voltage Overshoot:

5% of maximum voltage, to return within 2.5% of maximum voltage in less than 100ms

Voltage Ripple:

1% peak to peak of maximum voltage for frequencies ≤1kHz

Emission Current Parameters

Current Regulation:

Line: ±0.05% of rated output current over a ±10% change of nominal input line voltage

Load: ±0.1% of rated output current for a change from 50% to 100% of rated output voltage

Current Accuracy:

Current measured through the X-Ray tube is within ±2% of the programmed value

Current Risetime:

Standard: Ramp time shall be 500ms from 10% to 90% of maximum rated current

Optional: 5 seconds. Specify at time of order

Arc Intervention:

3 arcs in 10 seconds with a 200ms quench = Shutdown

Filament Configuration:

Internal high frequency AC filament drive with closed loop filament emission control

Analog Interface:

Ground referenced 0 to 9Vdc for all programming and monitoring signals. Relay contacts and open collector signals for other signals. See analog interface connector pin out table.

Digital Interface:

Jumpers are needed to be configured and the digital interface cable installed to enable the RS-232 interface.

Control Software:

A demo GUI is available for engineering evaluations

Interlock/Signals:

A hardware interlock functions in both analog and digital programming modes. The hardware X-Ray Enable signal only functions in analog programming mode.

Operating Temperature:

0°C to +40°C

Storage Temperature:

-40°C to +70°C

Humidity:

10% to 95% relative humidity, non-condensing

Cooling:

Customer provided 150cfm external cooling fan as required to maintain oil temperature below 55°C. (External cooling is not required if fan option is selected)

Input Line Connector:

3 pin, Phoenix Contact 1829167, SHV part number 105725-219. Mating connector Phoenix Contact #1805990, SHV part number 105808-475 provided with unit.

Analog Interface Connector:

15 pin D connector, male

Digital Interface Connector:

9 pin D connector, female

Grounding Point:

8-32 ground stud provided on chassis

Dimensions:

See line drawings

Weight:

32lbs (14.5kg)

Orientation:

Can be mounted in any orientation.

X-Ray Leakage:

Not to be greater than 0.5mR/hr at 5cm outside the external surface

Regulatory Approvals:

Compliant to EEC EMC Directive. Compliant to EEC Low Voltage Directive. UL/CUL recognized file E235530.

AC LINE POWER CONNECTOR— J1 THREE POSITION PHOENIX CONTACT

PIN	SIGNAL
1	Earth Ground
2	Line
3	Neutral

Mating connector provided with unit

RS-232 DIGITAL INTERFACE— J3 9 PIN FEMALE D CONNECTOR

PIN	SIGNAL	PARAMETERS
1	N/C	No Connection
2	TD	Transmit Data
3	RD	Receive Data
4	N/C	No Connection
5	SGND	Signal Ground
6	NC	No Connection
7	NC	No Connection
8	NC	No Connection
9	NC	No Connection

XRB ANALOG INTERFACE— J2 15 PIN MALE D CONNECTOR

PIN	SIGNAL	PARAMETERS
1	Power Supply Fault Output	Open collector, 35V @ 10mA max. high = no fault
2	mA Program Input	0 to 9.00Vdc = 0 to 100% rated output, Zin = 10MΩ
3	kV Program Input	0 to 9.00Vdc = 0 to 100% rated output, Zin = 10MΩ
4	X-Ray On Lamp Relay Output	Common, dry contacts, 30Vdc @ 1A, max
5	X-Ray On Lamp Relay Output	Normally open, X-Ray ON = closed
6	mA Monitor Output	0 to 9Vdc = 0 to 100% rated output, Zout = 10kΩ
7	X-Ray On Lamp Relay Output	Normally closed, X-Ray ON = open
8	kV Monitor Output	0 to 9.00Vdc = 0 to 100% rated output, Zout = 10kΩ
9	Signal Ground	Ground
10	Signal Ground	Ground
11	HV Interlock Return Input	Connect to Pin 12 to close HV interlock
12	HV Interlock Output	+15Vdc @ open, 5mA when connected to pin 11
13	X-Ray Enable Output	+15Vdc @ open, 5mA when connected to pin 15
14	X-Ray Status Output	Open collector, 35V @ 10mA max high = X-Ray OFF
15	X-Ray Enable Return Input	Connect to pin 13 to enable X-Ray generation

LED INDICATORS

INDICATOR	SIGNAL NAME	CONDITION Illuminated When...
LED 1	OV	High kV occurs
LED 2	UV	Low kV occurs
LED 3	UC	Low mA occurs
LED 4	OC	High mA occurs
LED 5	ARC FLT	Arc fault occurs
LED 6	OT	Over temperature occurs
LED 7	X-RAY ON	X-Rays are enabled
LED 8	PWR	Power is ON

OPTIONS

- RT** 5 second Risetime for both voltage and current
- CB** Cone Beam
- FN** Integrated Cooling Fan
- M** Elapsed Time Meter (measures X-Ray ON elapsed time)

How to Order:

Standard: PART NO.: XRB80N100
 Risetime, Cone Beam, Fan and Elapsed Time Meter Options
 PART NO.: XRB80N100/RT/CB/FN/M

DIMENSIONS: in.[mm]
Standard Unit

FRONT VIEW

NOTE: Shown with Elapsed Time Meter option

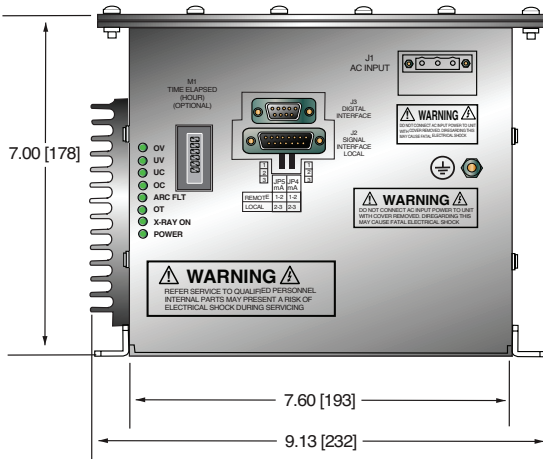

SIDE VIEW

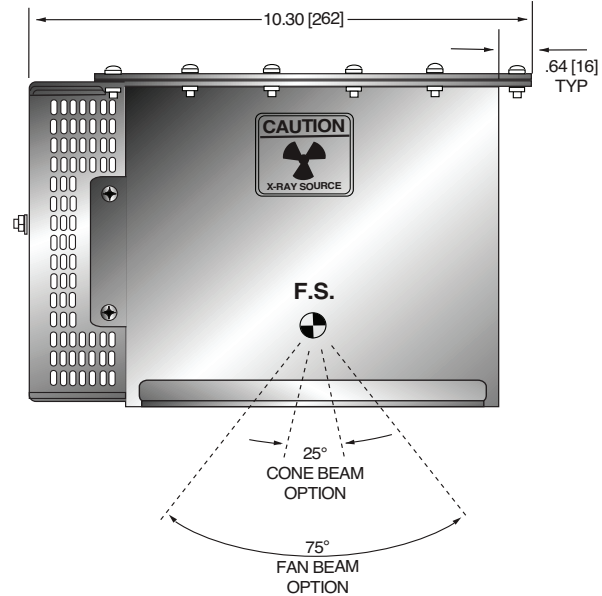

BACK VIEW

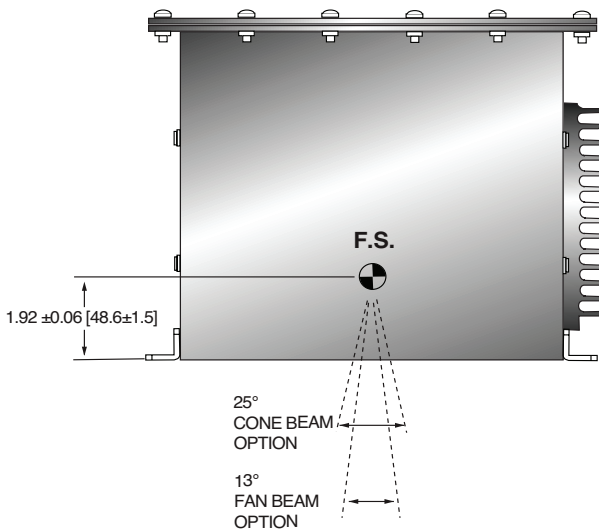

BOTTOM VIEW

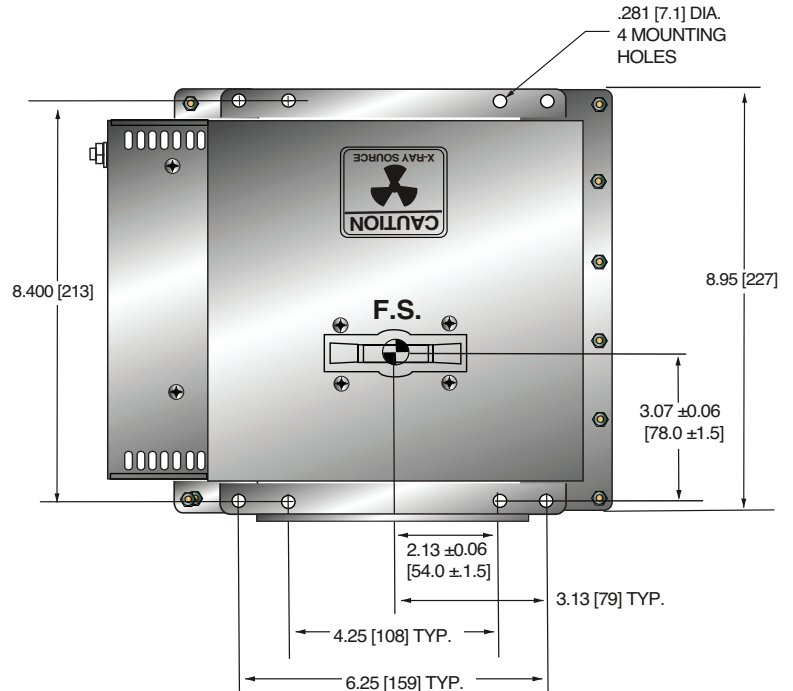

DIMENSIONS: in.[mm]

Cooling Fan Option

TOP VIEW

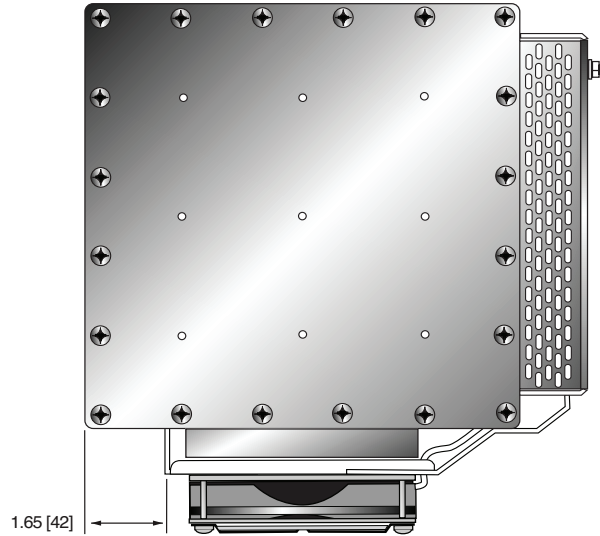

SIDE VIEW

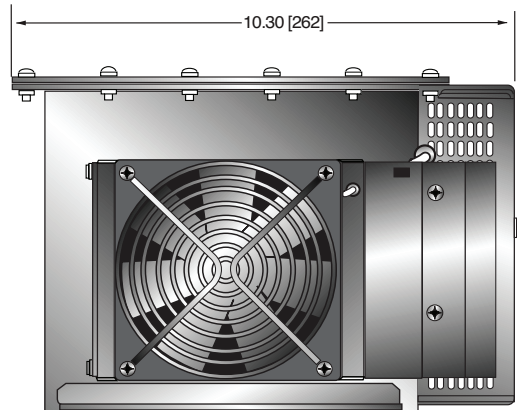

BACK VIEW

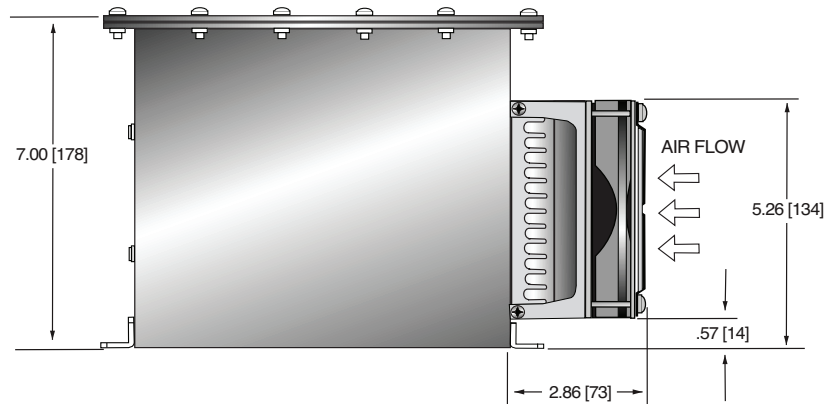

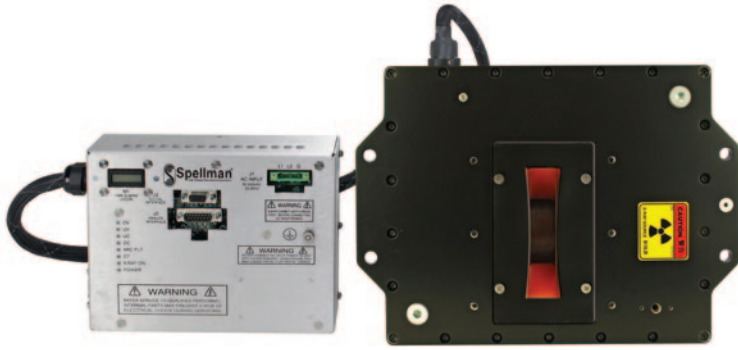

Spellman's XRB80PN100HR (high reliability) Monoblock® X-Ray source is designed for OEM applications powering its internal Bipolar X-Ray tube up to 80kV at 100W. Features like universal input, small package size and a standard RS-232 digital interface simplify integrating this Monoblock® into your X-Ray system. The XRB80PN100HR is available either with fan shaped (standard) or (optional) cone shaped beam geometries. Proprietary emission control circuitry provides excellent regulation of X-Ray tube current, along with outstanding stability performance. The XRB80PN100HR is designed for long field life.

TYPICAL APPLICATIONS

X-Ray Scanning, Thickness Measurement, Food Inspection, Fill Level Confirmation, Parcel Inspection

SPECIFICATIONS

X-Ray Characteristics:

Focal Spot: 0.8mm (IEC 336) standard
0.5mm (IEC 336) optional

Beam Filter:

Ultem: 3.00mm ± 0.15 mm
Oil: 7.5mm ± 0.25 mm
Glass: 1.7mm ± 0.2 mm
Be: 0.8mm

Beam Geometry:

Fan: The standard beam angular coverage will be 80° with the beam plane perpendicular to the X-Ray tube axis and 20° wide (with a 2° tolerance)
An optional 80° x 10° (with a 2° tolerance) is also available
Cone: Optional. 20° cone beam (with a 2° tolerance)

Input Voltage:

Power factor corrected input 0.98, 100-240Vac $\pm 10\%$
50/60Hz, 2A maximum

- **Integrated HV Supply, Filament Supply, X-Ray Tube, Beam Port and Control Electronics**
- **Compact & Lightweight**
- **Universal Input, Power Factor Corrected with Internal EMI Filter**
- **Can be Mounted in Any Physical Orientation**
- **Analog Monitoring Interface and Standard RS-232 Digital Interface**
- **Elapsed Time Meter Provided on Controller to Monitor X-Ray Tube Usage**

X-Ray Tube Voltage:

Nominal X-Ray tube voltage is adjustable 40kV (± 20 kV) to 80kV (± 40 kV)

X-Ray Tube Current:

150uA to 2.00mA over specified tube voltage range (100W max.)

X-Ray Tube Power:

100W maximum continuous

Voltage Regulation:

Line: $\pm 0.05\%$ of maximum output voltage over a $\pm 10\%$ change of nominal input line voltage

Load: $\pm 0.1\%$ of maximum rated voltage for 150uA to 2.00mA load change

Voltage Accuracy:

Voltage measured across the X-Ray tube is within $\pm 2\%$ of the programmed value

Voltage Risetime:

Standard: Ramp time shall be <500ms from 10% to 90% of maximum rated output voltage

Voltage Ripple:

0.5% peak to peak of maximum voltage for frequencies ≤ 1 kHz

Emission Current Parameters

Current Regulation:

Line: $\pm 0.05\%$ of rated output current over a $\pm 10\%$ change of nominal input line voltage

Load: $\pm 0.1\%$ of rated output current for a change from 50% to 100% of rated output voltage

Current Accuracy:

Current measured through the X-Ray tube is within $\pm 2\%$ of the programmed value

Current Risetime:

Standard: Ramp time shall be <500ms from 10% to 90% of maximum rated current

Arc Intervention:

4 arcs in 10 seconds with a
100ms quench/100ms re-ramp = Shutdown

Filament Configuration:

Internal AC filament drive with closed loop filament emission control

Analog Interface:

Ground referenced 0 to 9Vdc for all monitoring signals. Relay contacts and open collector signals for other signals. See analog interface connector pin out table.

Digital Interface:

The RS-232 interface allows for programming of kV, mA output and X-Ray enable. Provides monitoring for kV, mA output and oil temperature. Tolerance 3%. (with an additional 5µA offset at ≤10% mA programming)

Control Software:

A demo GUI is available for engineering evaluations

Operating Temperature:

0°C to +40°C

Storage Temperature:

-40°C to +70°C

Humidity:

10% to 95% relative humidity, non-condensing

Cooling:

X-Ray Tank: Customer provided 250 cfm external cooling fan as required to maintain oil temperature below 55°C.

Controller: Forced air via internal fan.

Input Line Connector:

3-pin Phoenix Contact 1829167. Mating connector provided with unit

Analog Interface Connector:

15 pin male D connector provided with unit

Digital Interface Connector:

9 pin female D connector provided with unit

Grounding Point:

8-32 ground stud provided on chassis

Dimensions:

X-Ray Tank: 11.3"L x 9.625"W x 4.93"H
(287.02mm x 244.4mm x 125.2mm)

Controller: 8.5"L x 6.70"W x 2.21"H
(215.9mm x 170.2mm x 56.1mm)

Weight:

X-Ray Tank: 36lbs (16.32kg)

Controller: 3.7lbs (1.68kg)

Orientation:

Can be mounted in any orientation.

X-Ray Leakage:

Not to be greater than 0.5mR/hr at 5cm outside the external surface.

Regulatory Approvals:

Compliant to EEC EMC Directive. Compliant to EEC Low Voltage Directive. UL/CUL recognized file E235530

**AC LINE POWER CONNECTOR—
J1 THREE POSITION PHOENIX CONTACT**

PIN	SIGNAL
1	Earth Ground
2	Line
3	Neutral

Mating connector provided with unit

**RS-232 DIGITAL INTERFACE—
J3 9 PIN FEMALE D CONNECTOR**

PIN	SIGNAL	PARAMETERS
1	N/C	No Connection
2	TD	Transmit Data
3	RD	Receive Data
4	N/C	No Connection
5	SGND	Signal Ground
6	N/C	No Connection
7	N/C	No Connection
8	N/C	No Connection
9	N/C	No Connection

**XRB80PN100HR ANALOG INTERFACE—
J2 15 PIN MALE D CONNECTOR**

PIN	SIGNAL	PARAMETERS
1	Power Supply Fault Output	Open collector, 35V @ 10mA max. high = no fault
2	N/C	No Connection
3	N/C	No Connection
4	X-Ray On Lamp Relay Output	Common, dry contacts, 30Vdc @ 1A, max
5	X-Ray On Lamp Relay Output	Normally open, X-Ray ON = closed
6	mA Monitor Output	0 to 9Vdc = 0 to 100% rated output, Zout = 10kΩ
7	X-Ray On Lamp Relay Output	Normally closed, X-Ray ON = open
8	kV Monitor Output	0 to 9.00Vdc = 0 to 100% rated output, Zout = 10kΩ
9	Signal Ground	Ground
10	Signal Ground	Ground
11	HV Interlock Return Input	Connect to Pin 12 to close HV interlock
12	HV Interlock Output	+15Vdc @ open, 5mA when connected to pin 11
13	X-Ray Enable Output	+15Vdc @ open, 5mA when connected to pin 15
14	X-Ray Status Output	Open collector, 35V @ 10mA max high = X-Ray OFF
15	X-Ray Enable Return Input	Connect to pin 13 to enable X-Ray generation (for local enable)

LED INDICATORS

INDICATOR	SIGNAL NAME	CONDITION Illuminated When...
LED 1	OV	High kV occurs
LED 2	UV	Low kV occurs
LED 3	UC	Low mA occurs
LED 4	OC	High mA occurs
LED 5	ARC FLT	Arc fault occurs
LED 6	OT	Over temperature occurs
LED 7	X-RAY ON	X-Rays are enabled
LED 8	PWR	Power is ON

OPTIONS

- CB** Cone Beam
- .5mm** .5mm focal spot X-Ray tube
- NF** 80° x 10° Narrow Fan beam
- RA** Right Angle cable

How to Order:

Standard:	PART NO.: XRB80PN100HR
Cone Beam Option	PART NO.: XRB80PN100HR/CB
0.5mm Focal Spot Option	PART NO.: XRB80PN100HR/.5mm
80° X 10° Narrow Fan Beam Option	PART NO.: XRB80PN100HR/NF
Cable Option:	PART NO.: XRB80PN100HR/RA

DIMENSIONS: in.[mm]

CONTROL UNIT TOP VIEW

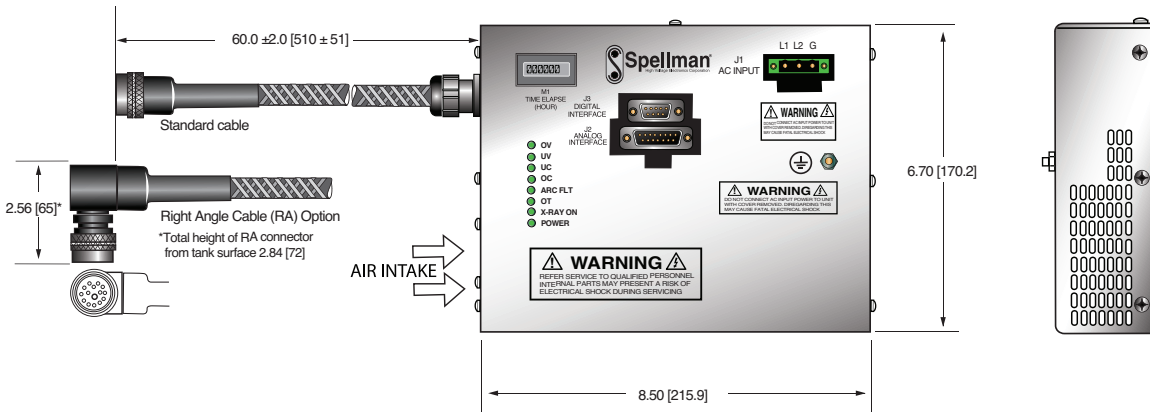

SIDE VIEW



BOTTOM VIEW

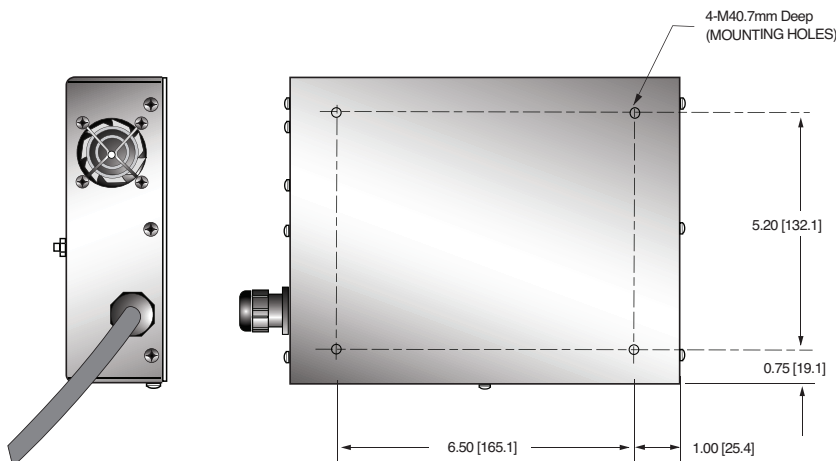

DIMENSIONS: in.[mm]

**GENERATOR TANK
 TOP VIEW**

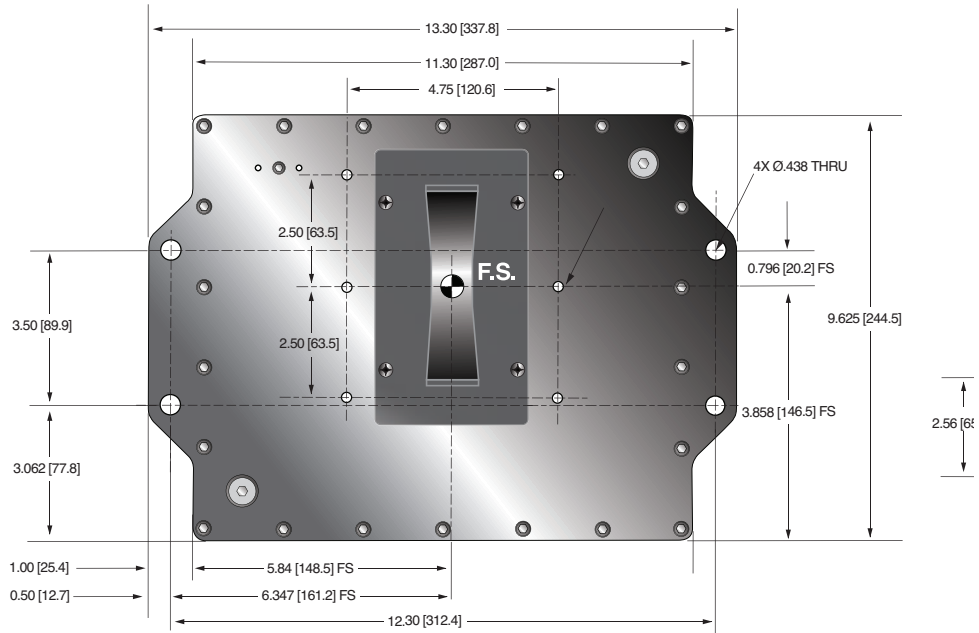

FRONT VIEW

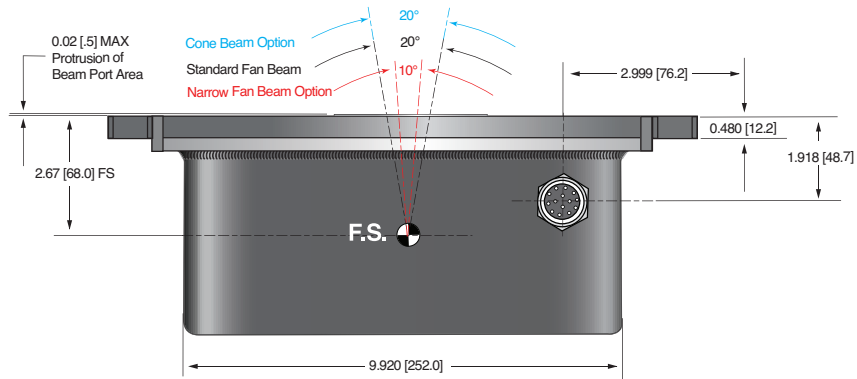

SIDE VIEW

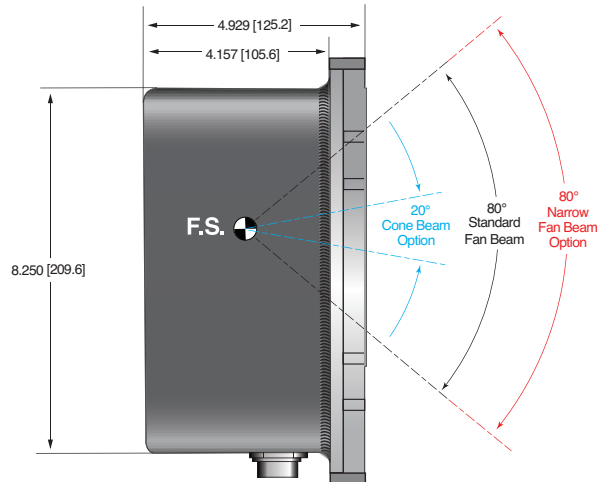



- **Integrated HV Supply, Filament Supply, X-Ray Tube, Beam Port and Control Electronics**
- **Compact & Lightweight**
- **Universal input, Power Factor Corrected with Internal EMI Filter**
- **Can be Mounted in Any Physical Orientation**
- **Analog Control Interface and Standard RS-232 Digital Interface**

www.spellmanhv.com/manuals/XRB100

Spellman's XRB100N100 Monoblock® X-Ray source is designed for OEM applications powering its internal X-Ray tube up to 100kV at 100W. Features like universal input, small package size and a standard analog and RS-232 digital interface simplify integrating this Monoblock® into your X-Ray system. Proprietary emission control circuitry provides excellent regulation of X-Ray tube current, along with outstanding stability performance.

TYPICAL APPLICATIONS

X-Ray Scanning: Food Inspection, Fill Level Confirmation and Security Applications

SPECIFICATIONS

X-Ray Characteristics:

Tube Type:	Stationary anode, tungsten target
Focal Spot:	0.5mm (IEC 336)
Beam Filter:	Lexan: 3.2mm Oil: 10mm ±0.1mm Glass: 1.8mm max
Beam Geometry:	Symmetrical fan 74° x 10° ±1°

Input Voltage:

Power factor corrected input 0.98, 100-240Vac ±10%
50/60Hz, 2A, maximum

X-Ray Tube Voltage:

Nominal X-Ray tube voltage is adjustable between
40kV to 100kV

X-Ray Tube Current:

100uA to 1mA over specified tube voltage range

X-Ray Tube Power:

100W maximum continuous

Voltage Regulation:

Line:	±0.1% of maximum output voltage over a ±10% change of nominal input line voltage
Load:	±0.1% of maximum rated voltage for 100uA to 1mA load change

Voltage Accuracy:

Voltage measured across the X-Ray tube is within
±2% of the programmed value

Voltage Risetime:

Ramp time shall be 1 second from 10% to
90% of maximum rated output voltage

Voltage Overshoot:

5% of maximum voltage, to return within 2.5% of
maximum voltage in less than 50ms

Voltage Ripple:

0.5% peak to peak of maximum voltage for
frequencies ≤1kHz

Emission Current Parameters

Current Regulation:

Line:	±0.5% of rated output current over a ±10% change of nominal input line voltage
Load:	±0.5% of rated output current for a change from 50% to 100% of rated output voltage

Current Accuracy:

Current measured through the X-Ray tube is within
±1% of the programmed value

Current Risetime:

Ramp time shall be 1 second from 10% to 90%
of maximum rated current

Arc Intervention:

3 arcs in 10 seconds with a 200ms quench = Shutdown

Filament Configuration:

Internal high frequency AC filament drive with closed loop
filament emission control

Analog Interface:

Ground referenced 0 to 9Vdc for all programming and monitoring signals. Relay contacts and open collector signals for other signals. See analog interface connector pin out table.

Digital Interface:

Jumpers are needed to be configured and the digital interface cable installed to enable the RS-232 interface.

Control Software:

A demo GUI is available for engineering evaluations.

Interlock/Signals:

A hardware interlock functions in both analog and digital programming modes. The hardware X-Ray Enable signal only functions in analog programming mode.

Operating Temperature:

0°C to +40°C

Storage Temperature:

-40°C to +70°C

Humidity:

10% to 95% relative humidity, non-condensing

Cooling:

Forced air and natural convection augmented by customer provided external cooling fan to maintain oil temperature below 55°C.

Input Line Connector:

3 pin, Phoenix Contact 1829167, SHV part number 105725-219. Mating connector Phoenix Contact #1805990, SHV part number 105808-475 provided with unit.

Analog Interface Connector:

15 pin D connector, male

Digital Interface Connector:

9 pin D connector, female

Grounding Point:

8-32 ground stud provided on chassis

Dimensions:

See page 3 of 3

Weight:

55lbs (25kg)

Orientation:

Can be mounted in any orientation.

X-Ray Leakage:

Not to be greater than 0.5mR/hr at 5cm outside the external surface.

**AC LINE POWER CONNECTOR—
J1 THREE POSITION PHOENIX CONTACT**

PIN	SIGNAL
1	Earth Ground
2	Line
3	Neutral

Mating connector provided with unit

**RS-232 DIGITAL INTERFACE—
J3 9 PIN FEMALE D CONNECTOR**

PIN	SIGNAL	PARAMETERS
1	N/C	No Connection
2	TD	Transmit Data
3	RD	Receive Data
4	N/C	No Connection
5	SGND	Signal Ground
6	NC	No Connection
7	NC	No Connection
8	NC	No Connection
9	NC	No Connection

**XRB ANALOG INTERFACE—
J2 15 PIN MALE D CONNECTOR**

PIN	SIGNAL	PARAMETERS
1	Power Supply Fault Output	Open collector, 35V @ 10mA max. high = no fault
2	mA Program Input	0 to 9.00Vdc = 0 to 100% rated output, Zin = 10MΩ
3	kV Program Input	0 to 9.00Vdc = 0 to 100% rated output, Zin = 10MΩ
4	X-Ray On Lamp Relay Output	Common, dry contacts, 30Vdc @ 1A, max
5	X-Ray On Lamp Relay Output	Normally open, X-Ray ON = closed
6	mA Monitor Output	0 to 9Vdc = 0 to 100% rated output, Zout = 10kΩ
7	X-Ray On Lamp Relay Output	Normally closed, X-Ray ON = open
8	kV Monitor Output	0 to 9.00Vdc = 0 to 100% rated output, Zout = 10kΩ
9	Signal Ground	Ground
10	Signal Ground	Ground
11	HV Interlock Return Input	Connect to Pin 12 to close HV interlock
12	HV Interlock Output	+15Vdc @ open, 5mA when connected to pin 11
13	X-Ray Enable Output	+15Vdc @ open, 5mA when connected to pin 15
14	X-Ray Status Output	Open collector, 35V @ 10mA max high = X-Ray OFF
15	X-Ray Enable Return Input	Connect to pin 13 to enable X-Ray generation

LED INDICATORS

INDICATOR	SIGNAL NAME	CONDITION Illuminated When...
LED 1	OV	High kV occurs
LED 2	UV	Low kV occurs
LED 3	UC	Low mA occurs
LED 4	OC	High mA occurs
LED 5	ARC FLT	Arc fault occurs
LED 6	OT	Over temperature occurs
LED 7	X-RAY ON	X-Rays are enabled
LED 8	PWR	Power is ON

DIMENSIONS: in.[mm]

**X-RAY GENERATOR
FRONT VIEW**

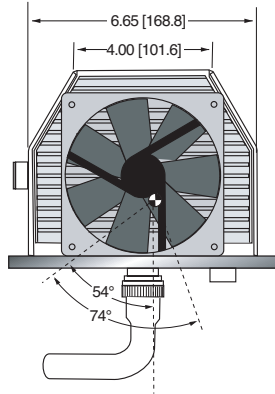

TOP VIEW

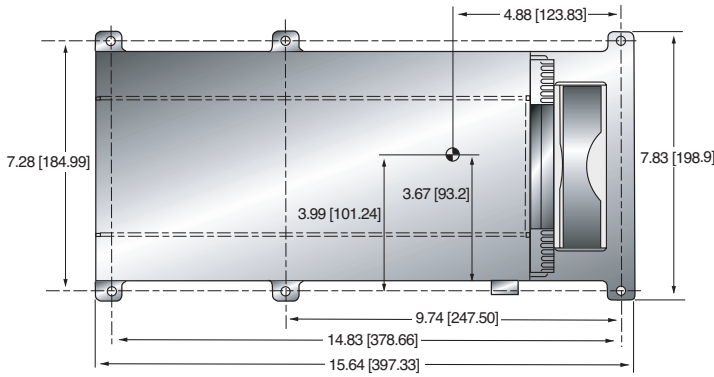

SIDE VIEW

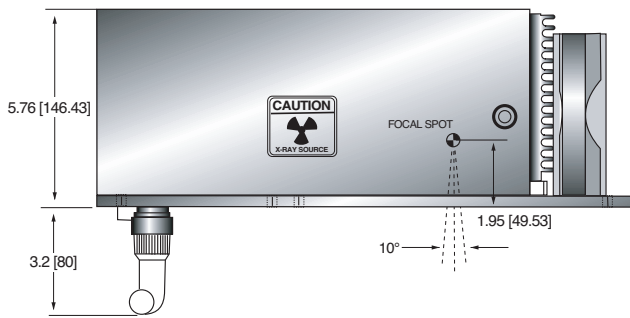

BOTTOM VIEW

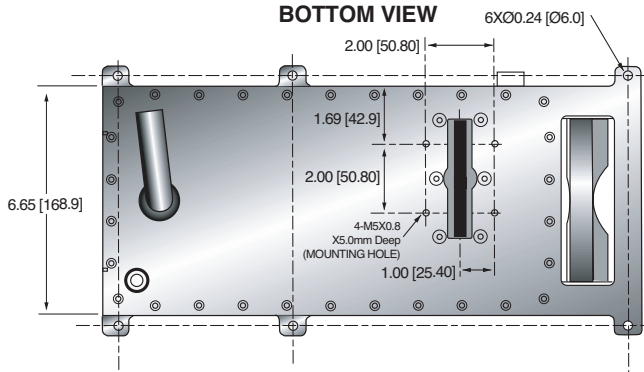

**CONTROL UNIT
FRONT VIEW**

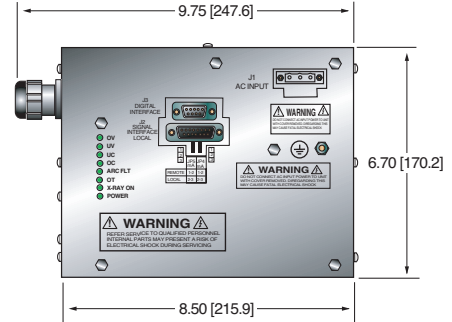

TOP VIEW



SIDE VIEW

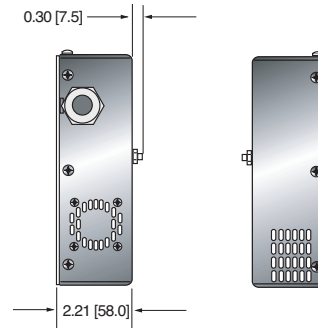

BOTTOM VIEW

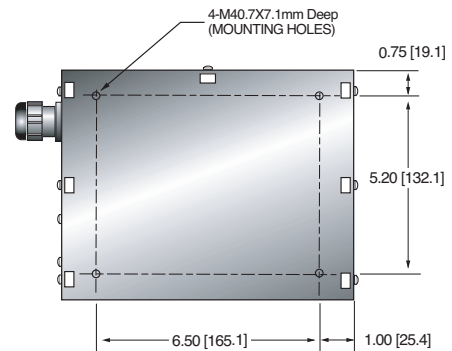



Spellman's XR BHR (high reliability) Series of Monoblock® X-Ray sources are designed for OEM applications powering their internal Bipolar X-Ray tube at 80kV and 100kV at power levels of 100W, 210W, 350W and 500W. Features such as universal input, compact package size and a standard RS-232 digital interface simplify integration of any XR BHR model into your X-Ray system. Each XR BHR model is available with fan shaped (standard) or cone shaped (optional) beam geometries. Proprietary emission control circuitry provides excellent regulation of X-Ray tube current, along with outstanding stability performance. The XR BHR Series is designed for long field life and available with a warranty of up to 3 years.

TYPICAL APPLICATIONS

Food Inspection Systems, Fill Level Confirmation Systems, Security Scanning Systems, Industrial NDT Systems, Thickness/Plating Measurement Systems

OPTIONS

- CB** Cone Beam
- .5mm** .5mm focal spot X-Ray tube

SPECIFICATIONS

X-Ray Characteristics:

Focal Spot: 0.8mm (IEC 336) standard
0.5mm (IEC 336) optional

Beam Filter:

- Ultem: 1.50mm ±0.15mm
- Oil: 9.0mm ±0.25mm
- Glass: 1.7mm ±0.2mm
- Be: 0.8mm

Beam Geometry:

- Fan: Standard. The beam angular coverage will be 90° with the beam plane perpendicular to the X-Ray tube axis and 12° wide (with a 2° tolerance)
- Cone: Optional. 40° cone beam (with a 2° tolerance)

Input Voltage:

100- 240Vac, ±10%, 50/60 Hertz, .98 power factor

Input Current:

- 100W @ 1.4A
- 210W @ 2.8A
- 350W @ 4.6A
- 500W @ 6.6A

- **Compact & Lightweight**
- **Universal Input, Power Factor Corrected**
- **Can be Mounted in Any Physical Orientation**
- **Analog Monitoring Interface, Standard RS-232 Digital Interface and Ethernet**
- **Real Time Clock to Record Total X-Ray ON Time. X-Ray ON Time is Accessible via RS-232 Digital Interface or Ethernet**

X-Ray Tube Voltage:

See table

X-Ray Tube Current:

See table

X-Ray Tube Power:

See table

Voltage Regulation:

- Line: ±0.05% of maximum output voltage over a ±10% change of nominal input line voltage
- Load: ±0.1% of maximum rated voltage for 150uA to full rated load change

Voltage Accuracy:

Voltage measured across the X-Ray tube is within ±2% of the programmed value

Voltage Risetime:

Standard ramp time shall be <500ms from 10% to 90% of maximum rated output voltage

Voltage Ripple:

0.5% peak to peak of maximum voltage for frequencies ≤1kHz

Emission Current Parameters

Current Regulation:

- Line: ±0.05% of rated output current over a ±10% change of nominal input line voltage
- Load: ±0.1% of rated output current for a change from 50% to 100% of rated output voltage

Current Accuracy:

Current measured through the X-Ray tube is within ±2% of the programmed value

Current Risetime:

Standard ramp time shall be <500ms from 10% to 90% of maximum rated current

Arc Intervention:

4 arcs in 10 seconds with a 100ms quench/100ms re-ramp = Shutdown

Filament Configuration:

Internal floating AC filament drive with closed loop filament emission control circuitry

Analog Interface:

Ground referenced 0 to 9Vdc for all monitoring signals. Relay contacts and open collector signals for other signals. See analog interface connector pin out table.

Digital Interface:

The RS-232 interface allows for programming of kV, mA output and X-Ray enable. Provides monitoring for kV, mA output and oil temperature.

Operating Temperature:

0°C to +40°C

Storage Temperature:

-40°C to +70°C

Humidity:

10% to 95% relative humidity, non-condensing

Cooling:

X-Ray Tank:

- 100W: Convection/customer supplied forced air so tank is <55°C
- 210W: Externally powered forced air cooling, 24Vdc @ 2A
- 350W: Externally powered forced air cooling with oil pump and heat exchanger, 24Vdc @ 5A
- 500W: Externally powered forced air cooling with oil pump and heat exchanger, 24Vdc @ 5A

Controller: Forced air via internal fan.

Grounding Point:

8-32 ground stud provided on chassis

Dimensions:

- X-Ray Tank: see drawings
- 100W/210W Controller: see drawings
- 350W/500W Controller: see drawings

Weight:

- X-Ray Tank:
 - 100W @ 75 lbs. (34kg)
 - 210W @ 75lbs. (34kg)
 - 350W @ 81.5lbs. (37kg)
 - 500W @ 81.5lbs. (37kgs)
- Controller:
 - 100W/210W: 4 pounds (1.18kg)
 - 350W/500W: 7 pounds (3.18kg)

Orientation:

Can be mounted in any orientation.

X-Ray Leakage:

Not to be greater than 0.5mR/hr at 5cm outside the external surface.

Regulatory Approvals:

Pending

MODEL SELECTION TABLE

Model	Maximum Voltage	Maximum Current	Maximum Power
XRB80PN210HR	80kV	5.25mA	210 watts
XRB80PN350HR	80kV	8mA	350 watts
XRB80PN500HR	80kV	8mA	500 watts
XRB100PN100HR	100kV	2mA	100 watts
XRB100PN210HR	100kV	4.2mA	210 watts
XRB100PN350HR	100kV	7mA	350 watts
XRB100PN500HR	100kV	8mA	500 watts

LED INDICATORS for 100W and 200W Units

INDICATOR	SIGNAL	CONDITION Illuminated When...	LED COLOR
1	OV Error 6	High kV occurs	Red
2	UV Error 5	Low kV occurs	Red
3	UC Error 4	Low mA occurs	Red
4	Power On	AC input power is present	Green
5	OC Error 3	High mA occurs	Red
6	ARC Error 2	Arc fault occurs	Red
7	OT Error 1	Over temperature occurs	Red
8	X-Ray On	X-Rays are being generated	Green

LED INDICATORS for 350W and 500W Units

INDICATOR	SIGNAL	CONDITION Illuminated When...	LED COLOR
1	OV Error 6	High kV occurs	Red
2	UV Error 5	Low kV occurs	Red
3	UC Error 4	Low mA occurs	Red
4	OC Error 3	High mA occurs	Red
5	ARC Error 2	Arc fault occurs	Red
6	OT Error 1	Over temperature occurs	Red
7	X-Ray On	X-Rays are being generated	Green
8	Power On	AC input power is present	Green

Power and Interface Connections for 100W and 210W Units

AC INPUT—6 PIN MOLEX

PIN	SIGNAL	PARAMETERS
1	AC Input (high)	100-240Vac (high)
2	Pin Removed	N/C
3	AC Input (neutral)	100-240Vac (neutral)
4	Pin Removed	N/C
5	N/C	N/C
6	N/C	N/C

ANALOG INTERFACE—7 PIN MOLEX

PIN	SIGNAL	PARAMETERS
1	X-Ray Interlock Enable	Apply +24Vdc to enable interlock. Open/removal of +24Vdc will cause X-Ray generation to stop.
2	X-Ray Interlock Enable Return	Ground reference for X-Ray Interlock.
3	Pin removed	N/C
4	kV Monitor	0-10Vdc = 0-100% rated output voltage. Zout = 10kΩ
5	Signal Ground	Signal Ground
6	mA Monitor	0-10Vdc = 0-100% rated output current. Zout = 10kΩ
7	X-Ray On	Open collector, High (Open) = No Fault, 35Vdc @10mA maximum

RS-232 DIGITAL INTERFACE—9 PIN MALE D CONNECTOR

PIN	SIGNAL	PARAMETERS
1	N/C	N/C
2	Transmitted Data	Conforms to EIA RS-232-C
3	Received Data	Conforms to EIA RS-232-C
4	N/C	N/C
5	Signal Ground	Signal Ground
6	N/C	N/C
7	N/C	N/C
8	N/C	N/C
9	N/C	N/C

ETHERNET DIGITAL INTERFACE—RJ45 8 PIN FEMALE CONNECTOR

PIN	SIGNAL	PARAMETERS
1	TX +	Transmit Data +
2	TX -	Transmit Data -
3	RX +	Receive Data +
4	N/C	No Connection
5	N/C	No Connection
6	RX -	Receive Data -
7	N/C	No Connection
8	N/C	No Connection

HV LAMP ON RELAY—3 PIN MOLEX

PIN	SIGNAL	PARAMETERS
1	Normally Closed dry contact	50V max. Rated for 1 amp or less, 50mA nominal load
2	Common	50V max. Rated for 1 amp or less, 50mA nominal load
3	Normally Open dry contact	50V max. Rated for 1 amp or less, 50mA nominal load

Power and Interface Connections for 350W and 500W Units

AC INPUT—3 PIN PHOENIX CONTACT

PIN	SIGNAL	PARAMETERS
1	AC Input (high)	100-240Vac (high)
2	Ground	Ground
3	AC Input (neutral)	100-240Vac (neutral)

DC INPUT FOR HEAT DISSIPATION UNIT—4 PIN AMP (210/350/500W)

PIN	SIGNAL	PARAMETERS
1	24Vdc	24Vdc @ 5 amps
2	24Vdc Return	24Vdc Return
3	24Vdc	24Vdc @ 5 amps
4	24Vdc Return	24Vdc Return

ANALOG INTERFACE—10 PIN PHOENIX CONTACT

PIN	SIGNAL	PARAMETERS
1	X-Ray Interlock Enable	Apply +24Vdc to enable interlock. Open/removal of +24Vdc will cause X-Ray generation to stop.
2	X-Ray Interlock Enable Return	Ground reference for X-Ray Interlock.
3	Pin removed	N/C
4	kV Monitor	0-10Vdc = 0-100% rated output voltage. Zout = 10kΩ
5	Signal Ground	Signal Ground
6	mA Monitor	0-10Vdc = 0-100% rated output current. Zout = 10kΩ
7	Fault Signal	Open collector, High (Open) = No Fault, 35Vdc @ 10mA maximum
8	HV ON Lamp Relay N/O	N/O dry contacts. 50 volts maximum. Rated for 1 amp or less, 50mA nominal load
9	HV ON Lamp Relay C	Common dry contacts. 50 volts maximum. Rated for 1 amp or less, 50mA nominal load
10	HV ON Lamp Relay N/C	N/C dry contacts. 50 volts maximum. Rated for 1 amp or less, 50mA nominal load

RS-232 DIGITAL INTERFACE—9 PIN MALE D CONNECTOR

PIN	SIGNAL	PARAMETERS
1	N/C	N/C
2	Transmitted Data	Conforms to EIA RS-232-C
3	Received Data	Conforms to EIA RS-232-C
4	N/C	N/C
5	Signal Ground	Signal Ground
6	N/C	N/C
7	N/C	N/C
8	N/C	N/C
9	N/C	N/C

ETHERNET DIGITAL INTERFACE—RJ45 8 PIN FEMALE CONNECTOR

PIN	SIGNAL	PARAMETERS
1	TX +	Transmit Data +
2	TX -	Transmit Data -
3	RX +	Receive Data +
4	N/C	No Connection
5	N/C	No Connection
6	RX -	Receive Data -
7	N/C	No Connection
8	N/C	No Connection

DIMENSIONS: in.[mm]

CONTROL UNIT TOP VIEW

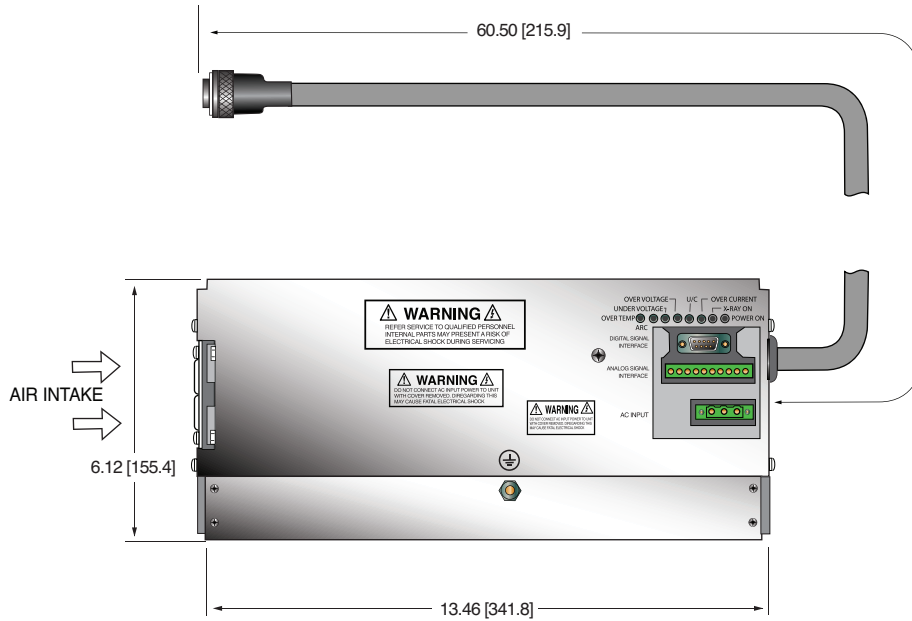

SIDE VIEW

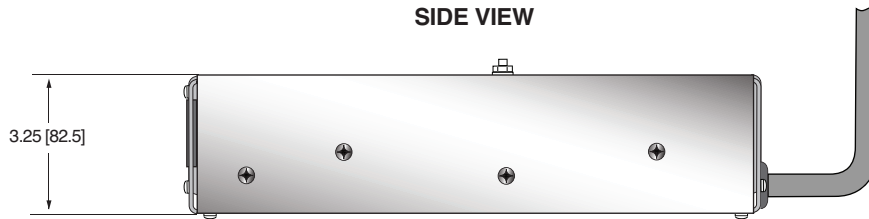

BACK VIEW



FRONT VIEW

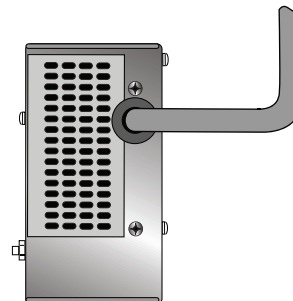

DIMENSIONS: in.[mm]

100W TANK TOP VIEW

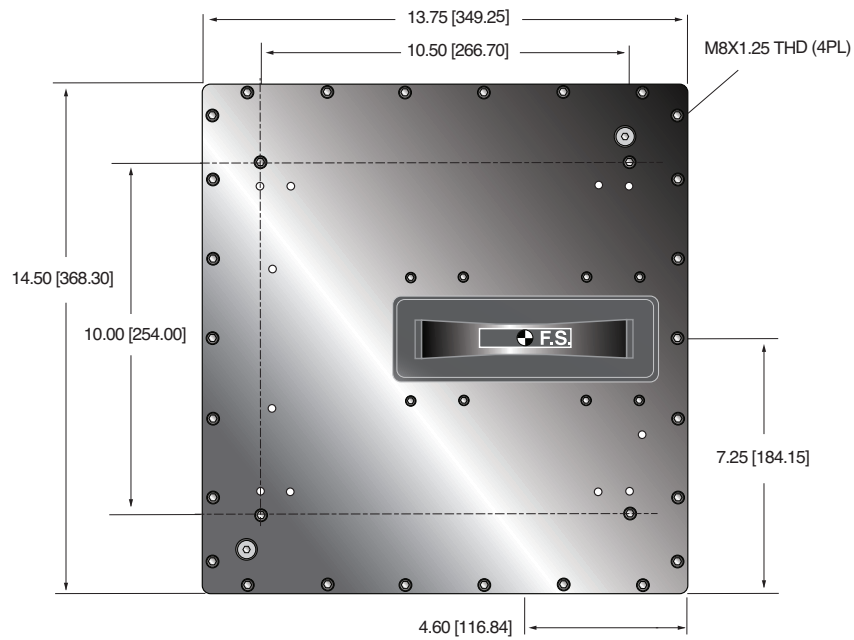

SIDE VIEW

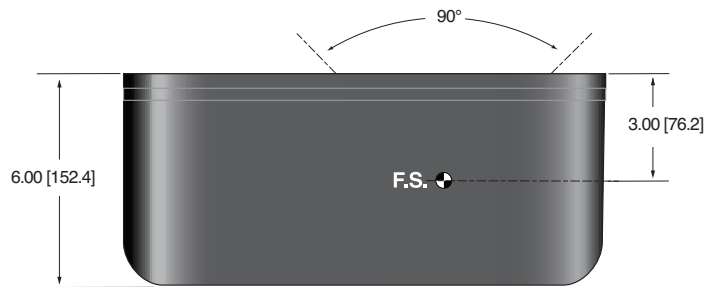

BACK VIEW

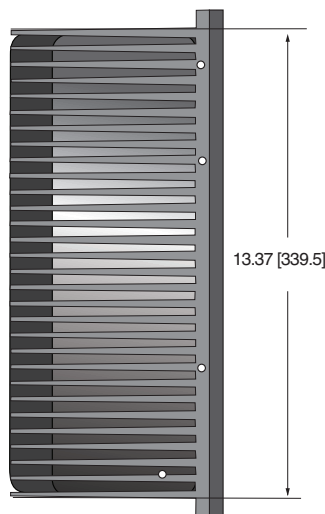

FRONT VIEW

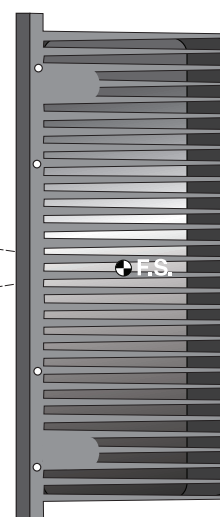

DIMENSIONS: in.[mm]

210W TANK TOP VIEW

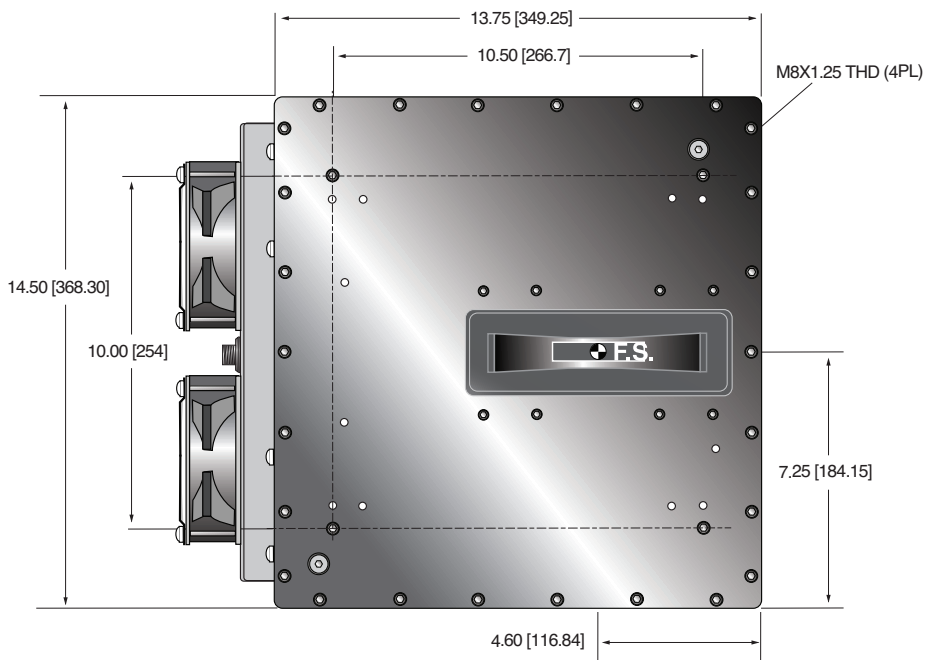

SIDE VIEW

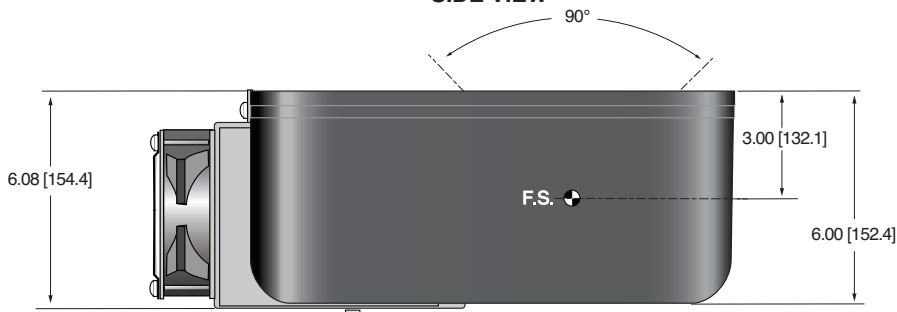

BACK VIEW



FRONT VIEW

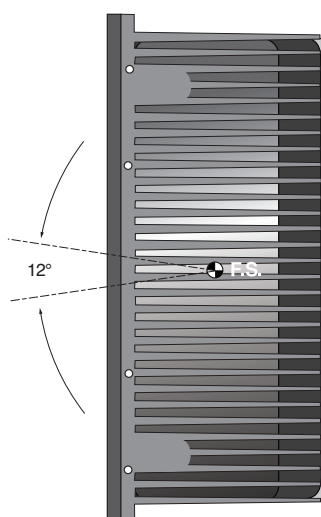

DIMENSIONS: in.[mm]

350/500W TANK

TOP VIEW

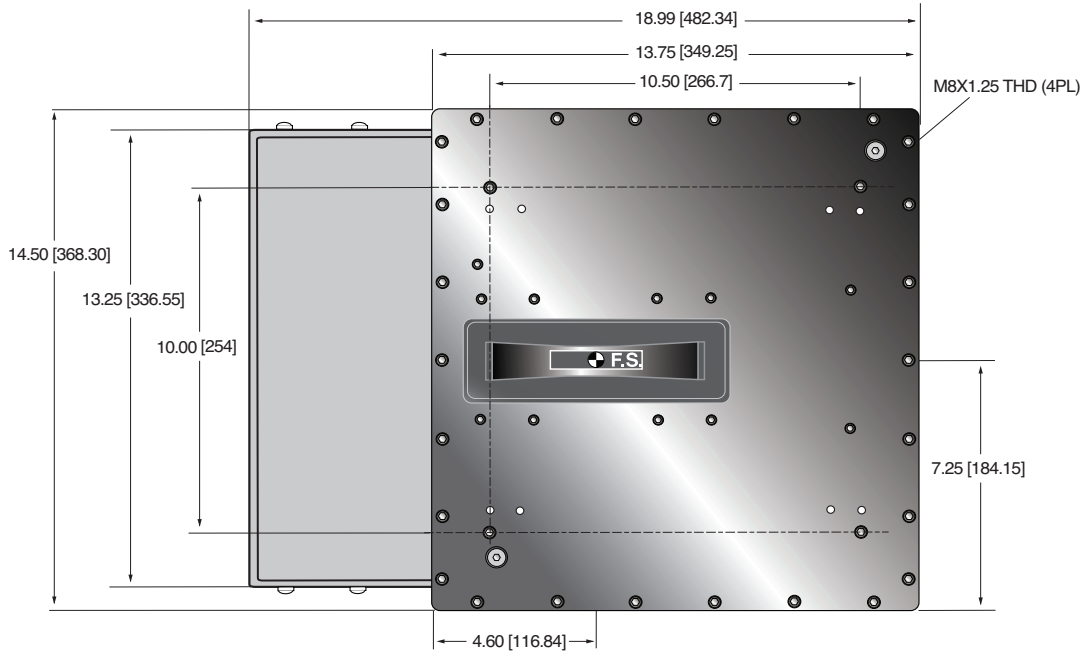

SIDE VIEW

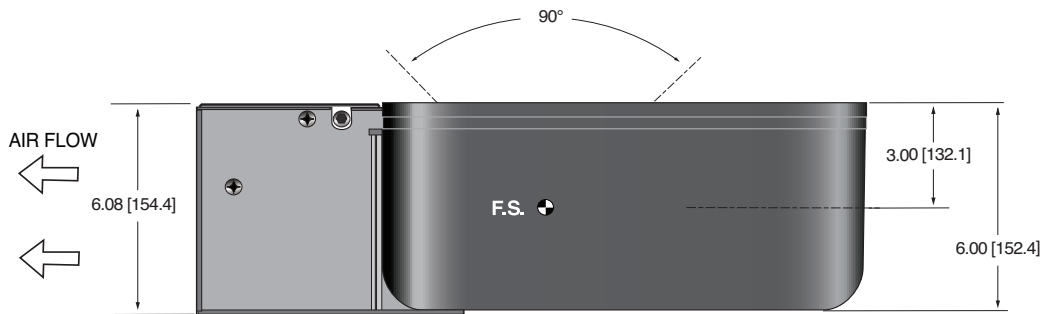

BACK VIEW

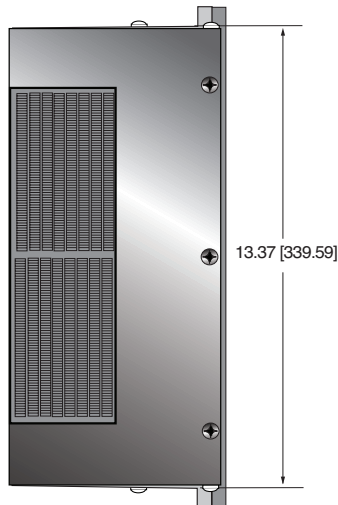

FRONT VIEW

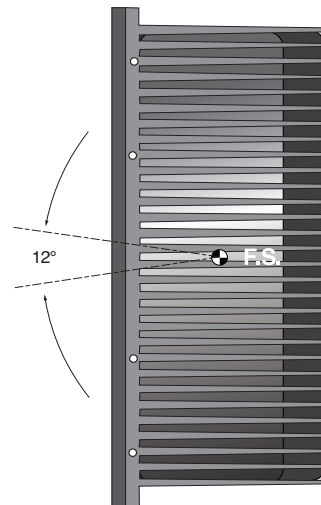



- **Integrated HV Supply, Filament Supply, X-Ray Tube, Beam Port and Control Electronics**
- **Compact & Lightweight**
- **Universal Input, Power Factor Corrected**
- **Can be Mounted in Any Physical Orientation**
- **Analog Monitoring and Standard RS-232 Digital Interface**

Spellman's XRB160PN192 Monoblock® X-Ray source is designed for OEM applications powering its internal X-Ray tube up to 160kV at 192W. Features like universal input, small package size and a standard analog and RS-232 digital interface simplify integrating this Monoblock® into your X-Ray system. Standard models are available with fan shaped beam geometry. Proprietary emission control circuitry provides excellent regulation of X-Ray tube current, along with outstanding stability performance.

TYPICAL APPLICATIONS

X-Ray Scanning: Plating Measurement, Food Inspection, Fill Level Confirmation and Security Applications

SPECIFICATIONS

X-Ray Characteristics:

Tube Type: Glass tube, Tungsten target, Be filter
Focal Spot: 0.8mm x 0.8mm
Beam Filter: 0.016" thick 6061 Al
Beam Geometry: Asymmetrical fan 80° x 10° ±2°

Input Voltage:

100-240Vac ±10%, 50/60Hz, 5A maximum

X-Ray Tube Voltage:

Nominal X-Ray tube voltage is adjustable between 80kV to 160kV

X-Ray Tube Current:

0.1mA to 1.2mA, 192W maximum over specified tube voltage range

X-Ray Tube Power:

192W maximum continuous

Voltage Regulation:

Line: ±0.1% for a ±10% input line change of nominal input line voltage
Load: ±0.1% for a 0.1mA to 1.2mA load change

Voltage Accuracy:

Voltage measured across the X-Ray tube is within ±2% of the programmed value

Voltage Risetime:

Ramp time shall be <200ms from 10% to 90% of rated output

Voltage Overshoot:

Within 5% of rated voltage in <10ms

Voltage Ripple:

1% pp of rated voltage @ ≤1kHz

Current Regulation:

Line: ±0.1% for a ±10% input line change of nominal input line voltage
Load: 0.5% @ 80-160kV, 0.1mA to 1.2mA

Current Accuracy:

Current measured through the X-Ray tube is within ±2% of the programmed value

Current Risetime:

<200ms from 10% to 90% of rated output

Arc Intervention:

4 arcs in 10 seconds with a 200ms quench = Shutdown

Filament Configuration:

Internal high frequency AC filament drive with closed loop filament emission control

Analog Interface:

0 to 10Vdc ground referenced signals

Digital Interface:

RS-232 interface.

Control Software:

A demo GUI for engineering evaluations will be provided for the RS-232 digital interface upon request.

Interlock Signals:

A hardware interlock function is provided

Operating Temperature:

0°C to +40°C

Storage Temperature:

-40°C to +70°C

Humidity:

10% to 95% relative humidity, non-condensing

Cooling:

Natural convection augmented by customer provided 250cfm cooling fans for 200W operation

Input Line Connector:

6 pin Molex 26-60-4060

Analog Interface Connector:

7 pin Molex 26-60-5070

Digital Interface Connector:

9 pin D connector, female

Grounding Point:

8-32 ground stud provided on chassis

Dimensions:

18" x 13.5" x 7.63" (458mm x 343mm x 193.80mm)

Weight:

90lbs (40.5kg)

Orientation:

Can be mounted in any orientation.

X-Ray Leakage:

Not to be greater than 0.5mR/hr at 5cm outside the external surface

Regulatory Approvals:

Compliant to EEC EMC Directive (external EMC filter required). Compliant to EEC Low Voltage Directive. UL/CUL recognized file E235530.

**AC INPUT POWER
J1 6 PIN CONNECTOR**

PIN	SIGNAL	PARAMETERS
1	Line	Line
2	Removed	N/C
3	Neutral	Neutral
4	Removed	N/C
5	Spare	N/C
6	Spare	N/C

**RS-232 DIGITAL INTERFACE—
JB16 9 PIN FEMALE D CONNECTOR**

PIN	SIGNAL	PARAMETERS
1	N/C	No Connection
2	TD	Transmit Data
3	RD	Receive Data
4	N/C	No Connection
5	SGND	Signal Ground
6	N/C	No Connection
7	N/C	No Connection
8	N/C	No Connection
9	N/C	No Connection

**ANALOG INTERFACE—
J7 7 PIN MOLEX CONNECTOR**

PIN	SIGNAL	PARAMETERS
1	Ex Gate	Low = X-Ray OFF, +12Vdc = X-Ray ON
2	Signal Ground	Ground
3	N/C	No Connection
4	kV Monitor	0-9 Vdc = 0 to 100% rated output
5	Signal Ground	Ground
6	mA Monitor	0 to 9Vdc = 0 to 100% rated output
7	Fault	Open collector, 35V @ 10mA max, High = No Fault

LED INDICATORS

INDICATOR	SIGNAL NAME	CONDITION Illuminated When...
LED 1	OV	High kV occurs
LED 2	UV	Low kV occurs
LED 3	UC	Low mA occurs
LED 4	OC	High mA occurs
LED 5	ARC FLT	Arc fault occurs
LED 6	OT	Over temperature occurs
LED 7	X-RAY ON	X-Rays are enabled
LED 8	PWR	Power is ON

DIMENSIONS: in.[mm]

FRONT VIEW

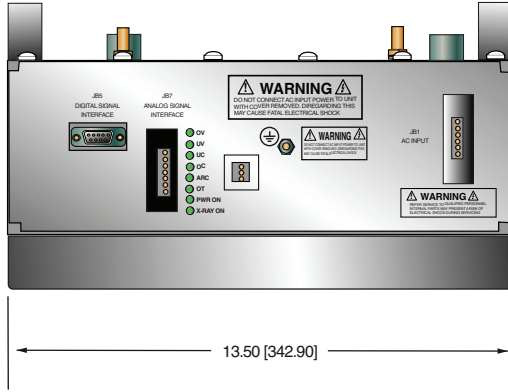

BACK VIEW

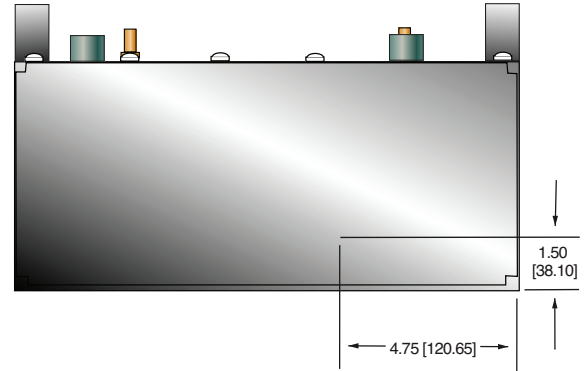

TOP VIEW

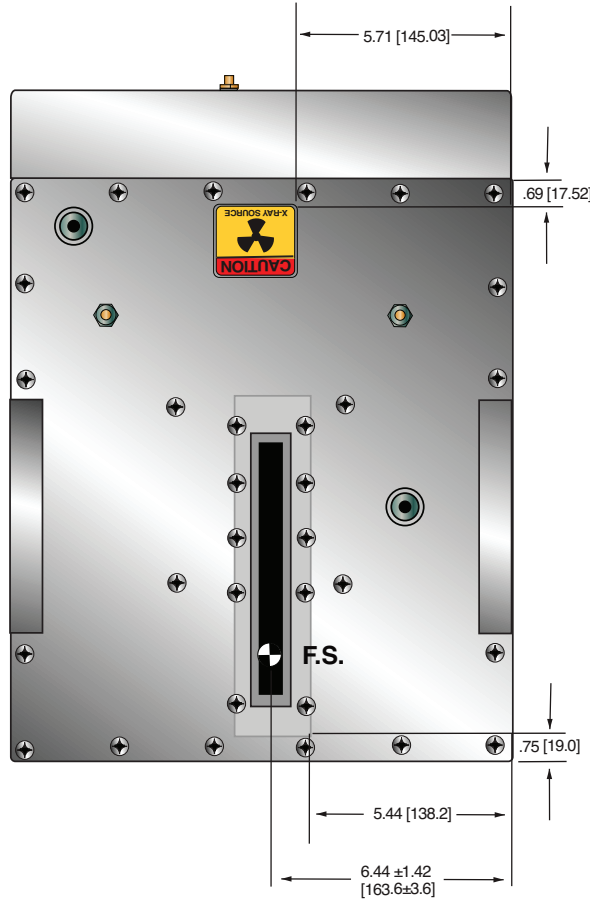

SIDE VIEW

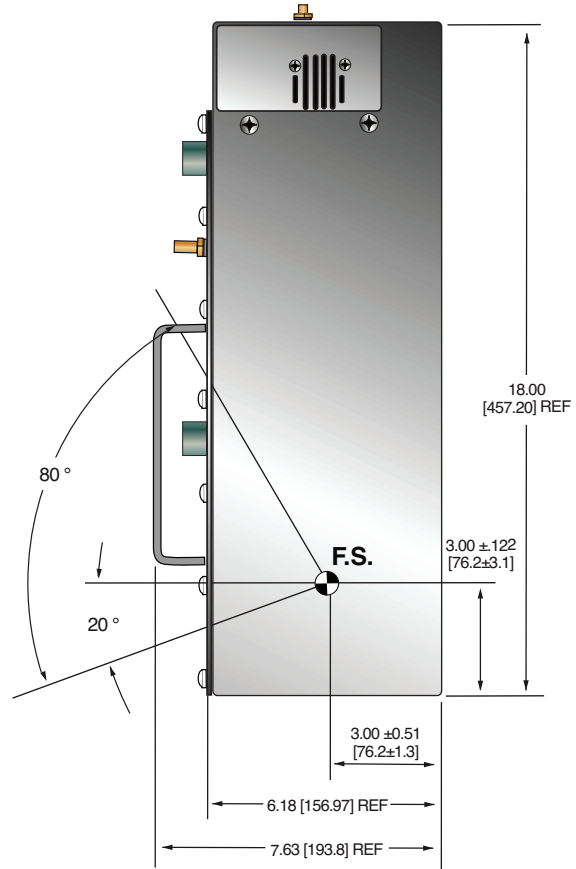



- **Integrated HV Supply, Filament Supply, X-Ray Tube, Beam Port and Control Electronics**
- **Compact & Lightweight**
- **Can be Mounted in Any Physical Orientation**
- **Standard RS-232 Digital Interface**

Spellman's XRB80PN320 Monoblock® X-Ray source is designed for OEM applications powering its internal X-Ray tube up to 80kV at 320W. Features like small package size and RS-232 digital interface simplify integrating this Monoblock® into your X-Ray system. Standard models are available with fan shaped beam geometry. Proprietary emission control circuitry provides excellent regulation of X-Ray tube current, along with outstanding stability performance.

TYPICAL APPLICATIONS

X-Ray Scanning: Food Inspection, Fill Level Confirmation and Security Applications

SPECIFICATIONS

X-Ray Characteristics:

Tube Type: Glass tube, Tungsten target, Be filter
Focal Spot: 0.8mm x 0.8mm (IEC 336)
Beam Filter: 5052 Al, 0.040" (± 0.01 ")
Beam Geometry: Asymmetrical fan 80° x 10° $\pm 2^\circ$

Input Voltage:

200-240Vac $\pm 10\%$, 50/60Hz, 6.5A max

X-Ray Tube Voltage:

Nominal X-Ray tube voltage is adjustable between 40kV to 80kV

X-Ray Tube Current:

0.5mA to 4mA over specified tube voltage range

X-Ray Tube Power:

320W maximum continuous

Voltage Regulation:

Line: $\pm 0.05\%$ for a $\pm 10\%$ input line change
Load: $\pm 0.05\%$ for a 0.5mA to 4mA load change

Voltage Accuracy:

Voltage measured across the X-Ray tube is within $\pm 2\%$ of the programmed value

Voltage Risetime:

Ramp time shall be $< 500\text{ms}$ from 10% to 90% of rated output

Voltage Overshoot:

Within 5% of rated voltage in $< 10\text{ms}$

Voltage Ripple:

$\leq 1\%$ p-p of rated voltage @ 1kHz

Current Regulation:

Line: $\pm 0.5\%$ @ 50-100% V nominal over specified Line range
Load: $\pm 0.5\%$ @ 50-100% V nominal over specified Load range

Current Accuracy:

Current measured through the X-Ray tube is within $\pm 2\%$ of the programmed value

Current Risetime:

$< 500\text{ms}$ from 10% to 90% of rated output

Arc Intervention:

4 arcs in 10 seconds = shutdown

Filament Configuration:

Internal high frequency AC filament drive with closed loop filament emission control

Analog Interface:

0 to 10Vdc ground referenced monitoring signals

Digital Interface:

RS-232

Control Software:

A demo GUI for engineering evaluations will be provided for the RS-232 digital interface upon request.

Interlock Signals:

A hardware interlock functions in digital programming modes.

Operating Temperature:

0°C to +40°C

Storage Temperature:

-40°C to +70°C

Humidity:

10% to 90% relative humidity, non-condensing

Cooling:

Heat exchanger w/fan and oil pump

Input Line Connector:

Terminal block, Schurter, Inc. part no. 6100-33

Digital Interface Connector:

9 pin D, female

Analog Monitoring Connector:

10 pin Phoenix Contact 1755503

Grounding Point:

8-32 ground stud provided on chassis

Dimensions:

See line drawing

Weight:

120lbs (54.4kg) maximum

Orientation:

Can be mounted in any orientation.

X-Ray Leakage:

Not to be greater than 0.5mR/hr at 5cm outside the external surface

Regulatory Approvals:

Designed to be compliant to EEC EMC Directive and EEC Low Voltage Directive with an external filter.

AC INPUT POWER TERMINAL BLOCK

PIN	SIGNAL	PARAMETERS
1	Line	Line
2	Line	Line
3	Line	Line
4	Neutral	Neutral
5	Neutral	Neutral
6	Neutral	Neutral

**RS-232 DIGITAL INTERFACE
JB16 9 PIN FEMALE D CONNECTOR**

PIN	SIGNAL	PARAMETERS
1	N/C	No Connection
2	TX	RS-232 Transmit
3	RX	RS-232 Receive
4	N/C	No Connection
5	SGND	Signal Ground
6	N/C	No Connection
7	N/C	No Connection
8	N/C	No Connection
9	N/C	No Connection

**ANALOG MONITORING—
JB11 10 PIN PHOENIX CONTACT**

PIN	SIGNAL	PARAMETERS
1	X-Ray Enable	+24Vdc = Enable X-Ray 0Vdc/Open = Disable X-Rays
2	RTN	Signal Return
3	N/C	No Connection
4	kV Monitor	0 to 10Vdc = 0 to 100kV, Zout = 10kΩ
5	SGND	Signal Return
6	mA Monitor	0 to 10Vdc = 0 to 5mA, Zout = 10kΩ
7	Fault	Open Collector, High (Open) = No Fault, 35Vdc @10mA max.
8	HV On Lamp, Relay N/O	Relay Normally Open, 50Vdc @ 1A maximum
9	HV On Lamp, Relay Common	Relay Common, 50Vdc @ 1A maximum
10	HV On Lamp, Relay N/C	Relay Normally Closed, 50Vdc @ 1A maximum

DIMENSIONS: in.[mm]

TOP VIEW

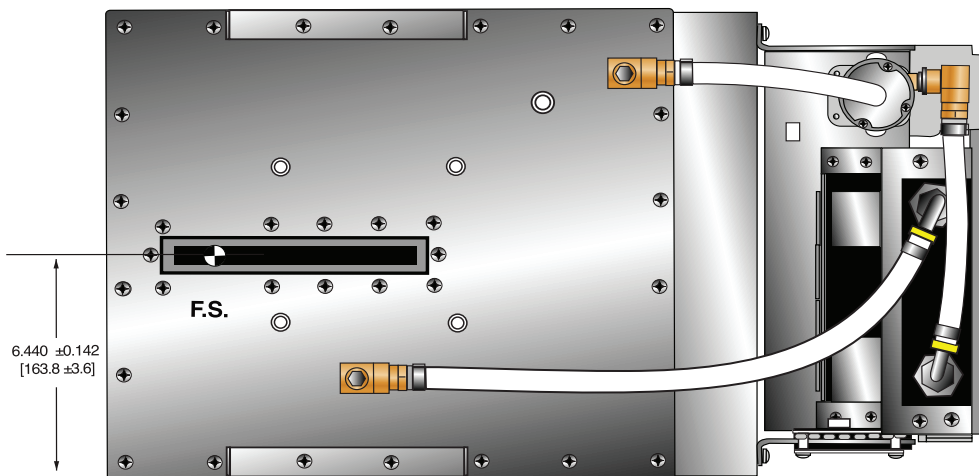

SIDE VIEW

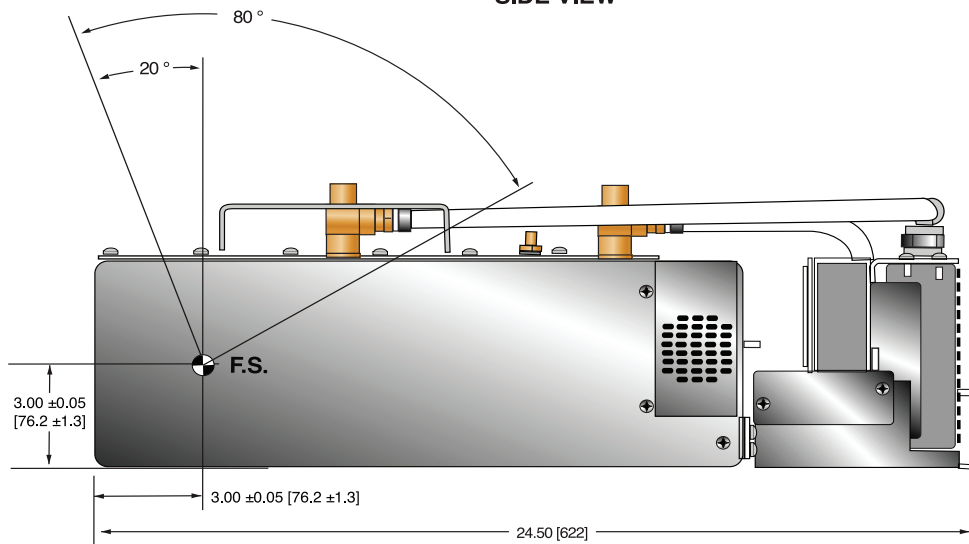

BACK VIEW

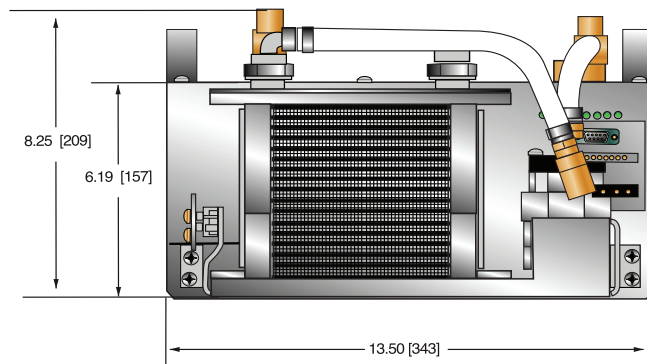

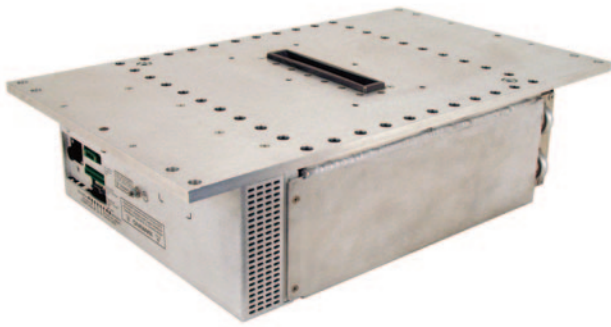

Spellman's XRB200PN400 Monoblock® X-Ray source is designed for OEM applications powering its internal X-Ray tube up to 200kV at 400W. Features like universal input, small package size, standard analog monitoring and RS-232 digital interface simplify integrating this unit into your X-Ray system. Standard models are available with fan shaped beam geometry. Proprietary emission control circuitry provides excellent regulation of X-Ray tube current, along with outstanding stability performance.

TYPICAL APPLICATIONS

X-Ray Scanning: Food Inspection,
Fill Level Confirmation, Security Applications

SPECIFICATIONS

X-Ray Characteristics:

Tube Type: Glass tube, Tungsten target, Be filter
Focal Spot: 0.8mm x 0.5mm (IEC336)
Beam Filter: Glass 1.8mm, Oil 10mm, Al 1mm
Beam Geometry: Symmetrical fan 85° x 10° ±1°

Input Voltage:

100Vac-240Vac ±10%, 50/60Hz, 6A maximum

X-Ray Tube Voltage:

Nominal X-Ray tube voltage is adjustable between 100kV to 200kV

X-Ray Tube Current:

0.5mA to 2mA over specified tube voltage range

X-Ray Tube Power:

400W maximum continuous (350W average without external forced air)

Voltage Regulation:

Line: ±0.1% for a ±10% input line change
Load: ±0.1% for a 0.5mA to 2mA load change

Voltage Accuracy:

Voltage measured across the X-Ray tube is within ±1% of the programmed value

Voltage Risetime:

<1 second from 10% to 90% of rated output

- **Integrated HV Supply, Filament Supply, X-Ray Tube, Beam Port and Control Electronics**
- **Compact & Lightweight**
- **Universal Input, Power Factor Corrected**
- **Can be Mounted in Any Physical Orientation**
- **Analog Monitoring and Standard RS-232 Digital Interface**

Voltage Overshoot:

5% in less than 100ms

Voltage Ripple:

≤0.2% pp of rated maximum voltage

Current Regulation:

Line: ±0.1% @ 100-200kV, 0.25mA to 2mA
Load: ±0.5% @ 100-200kV, 0.25mA to 2mA

Current Accuracy:

Current measured through the X-Ray tube is within ±1% of the programmed value

Current Risetime:

<1 second from 10% to 90% of rated output

Arc Intervention:

4 arcs in 10 seconds = shutdown

Filament Configuration:

Internal high frequency AC filament drive with closed loop filament emission control

Digital Interface:

RS-232 interface.

Control Software:

A demo GUI for engineering evaluations will be provided for the RS-232 digital interface upon request.

Interlock Signals:

A hardware interlock function is provided

Operating Temperature:

0°C to +40°C

Storage Temperature:

-40°C to +70°C

Humidity:

5% to 95% relative humidity, non-condensing

Cooling:

Heat exchanger w/fan and oil pump, powered from 24Vdc, 2A power supply (customer provided). External forced air cooling if needed to keep oil temperature below 55°C

Input Line Connector:

3 pin Phoenix Contact 1829167

Analog Interface Connector:

10 pin Phoenix Contact 1755503

Digital Interface Connector:

9 pin D connector, female

Grounding Point:

M5 ground stud provided on chassis

Dimensions:

See drawing

Weight:

148.0lbs (67.0kg)

Orientation:

Can be mounted in any orientation.

X-Ray Leakage:

Not to be greater than 5uSv/hr at 5cm outside the external surface

**AC INPUT POWER
3 PIN PHOENIX CONTACT**

PIN	SIGNAL	PARAMETERS
1	Line	Line
2	GND	Ground
3	Neutral	Neutral

**DC POWER FOR HEAT DISSIPATION UNIT
4 PIN AMP 206061-1 CONNECTOR**

PIN	SIGNAL	PARAMETERS
1	+24	+24Vdc
2	RTN	Return
3	+24	+24Vdc
4	RTN	Return

**ANALOG INTERFACE—
10 PIN PHOENIX CONTACT**

PIN	SIGNAL	PARAMETERS
1	X-Ray	+24Vdc = enable X-Ray
2	X-Ray Return	X-Ray Return
3	N/C	N/C
4	kV Monitor Output	0 to 9Vdc = 0 to 100% Rated Voltage
5	SGND	Signal Ground
6	mA Monitor Output	0 to 9Vdc = 0 to 100% Rated Current
7	Fault	Open Collector, Open = No Fault
8	Relay N/O	HV On, 50V @ 1A maximum
9	Relay Common	HV On, 50V @ 1A maximum
10	Relay N/C	HV On, 50V @ 1A maximum

**RS-232 DIGITAL INTERFACE—
9 PIN FEMALE D CONNECTOR**

PIN	SIGNAL	PARAMETERS
1	N/C	No Connection
2	Transmit Data	Conforms to E/A RS-232-C
3	Receive Data	Conforms to E/A RS-232-C
4	N/C	No Connection
5	SGND	Signal Ground
6	N/C	No Connection
7	N/C	No Connection
8	N/C	No Connection
9	N/C	No Connection

DIMENSIONS: in.[mm]

FRONT VIEW

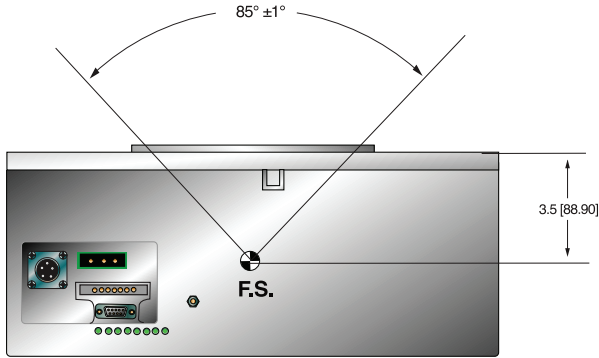

BACK VIEW



TOP VIEW

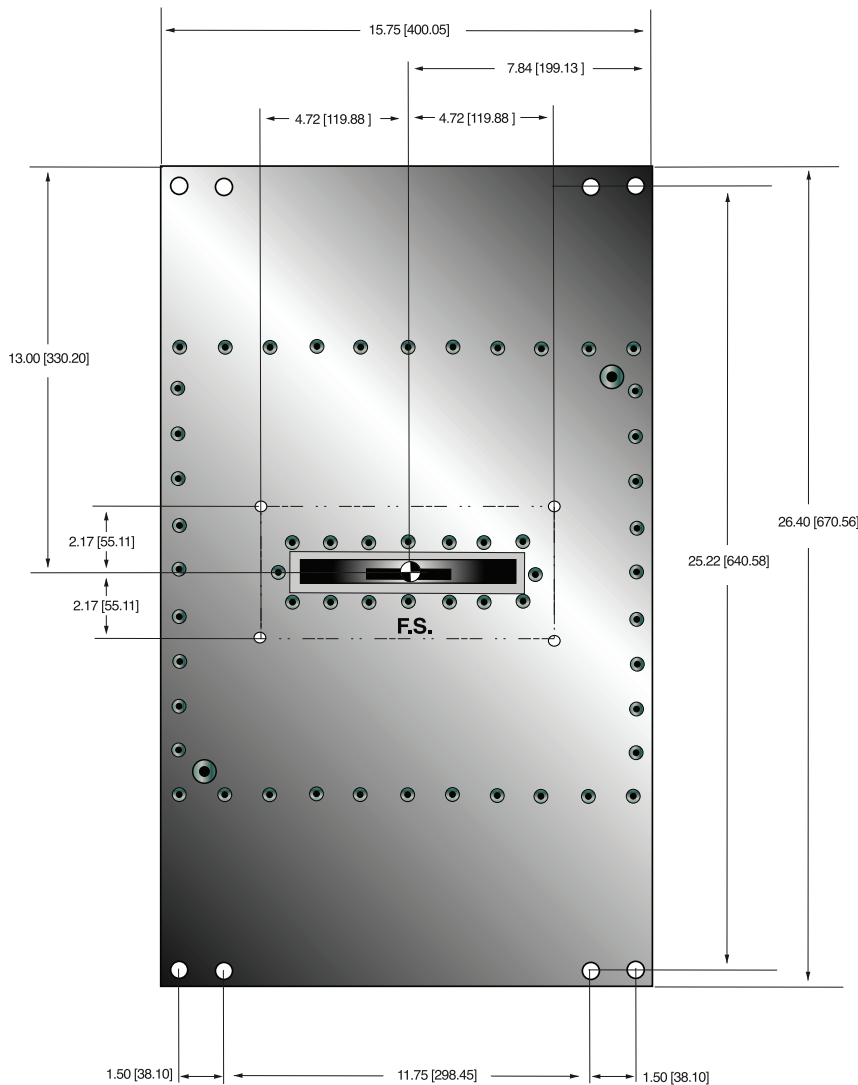

SIDE VIEW

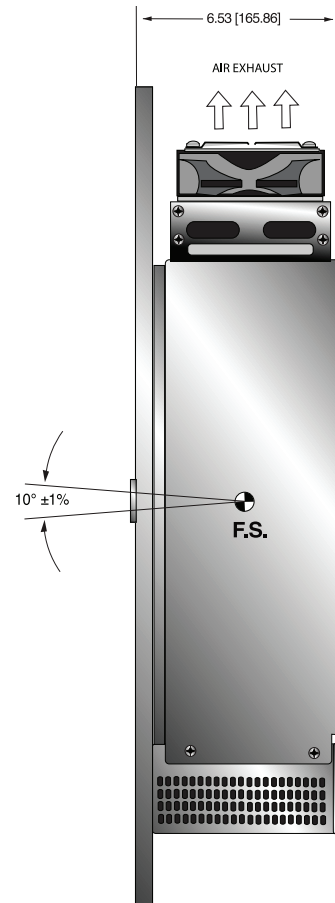

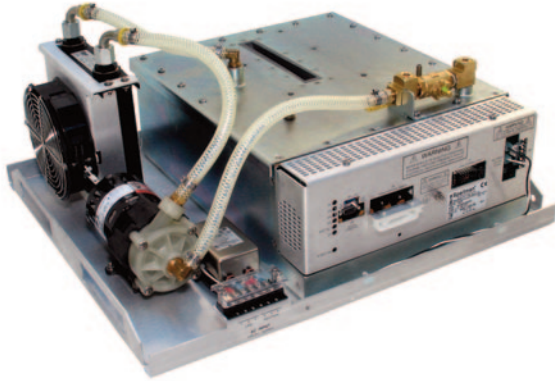

- **Integrated HV Supply, Filament Supply, X-Ray Tube, Beam Port and Control Electronics**
- **Compact & Lightweight**
- **Power Factor Corrected with Internal EMI Filter**
- **Can be Mounted in Any Physical Orientation**
- **Analog Monitoring and Standard RS-232 Digital Interface**

Spellman's XRB160PN480/1 Monoblock® X-Ray source is designed for OEM applications powering its internal X-Ray tube up to 160kV at 480W. Features like power factor correction, small package size, standard analog monitoring and RS-232 digital interface simplify integrating this Monoblock® into your X-Ray system. Standard models are available with fan shaped beam geometry. Proprietary emission control circuitry provides excellent regulation of X-Ray tube current, along with outstanding stability performance.

TYPICAL APPLICATIONS

X-Ray Scanning: Food Inspection, Fill Level Confirmation and Security Applications

SPECIFICATIONS

X-Ray Characteristics:

Tube Type: Glass tube, Tungsten target, Be filter
Focal Spot: 0.8mm x 0.8mm (IEC336)
Beam Filter: Curved 1mm Al
Beam Geometry: Asymmetrical fan 80° x 10° ±2°

Input Voltage:

220Vac, ±10%, 50/60Hz, 6.5A max

X-Ray Tube Voltage:

Nominal X-Ray tube voltage is adjustable between 80kV to 160kV

X-Ray Tube Current:

0.25mA to 3mA over specified tube voltage range

X-Ray Tube Power:

480W maximum continuous

Voltage Regulation:

Line: ±0.1% for a ±10% input line change of nominal input line voltage
Load: ±0.1% for a 0.25mA to 3mA load change

Voltage Accuracy:

Voltage measured across the X-Ray tube is within ±2% plus 1.785kV of the programmed value

Voltage Risetime:

Ramp time shall be ≤2 seconds from 10% to 90% of rated output

Voltage Overshoot:

±1% switching between 90kV to 160kV @ 0.25mA

Voltage Ripple:

≤0.1% of rated voltage from 10Hz to 1kHz

Current Regulation:

Line: ±0.5% @ 80-160kV, 0.25mA to 3mA
Load: ±0.5%, 0.25mA to 3mA

Current Accuracy:

Current measured through the X-Ray tube is within 2% of the programmed value

Current Risetime:

≤2 seconds from 10% to 90% of rated output

Arc Intervention:

4 arcs in 10 seconds = shutdown

Filament Configuration:

Internal high frequency AC filament drive with closed loop filament emission control

Analog Interface:

0 to 10Vdc ground referenced signals

Digital Interface:

RS-232 interface

Control Software:

A demo GUI for engineering evaluations will be provided for the RS-232 digital interface upon request.

Interlock Signals:

A hardware interlock function is provided

Operating Temperature:

0°C to +40°C

Storage Temperature:

-20°C to +70°C

Humidity:

5% to 95% relative humidity, non-condensing

Cooling:

Heat exchanger w/fan and oil pump,
powered from AC

Input Line Connector:

6 position terminal block

Analog Interface Connector:

7 pin Molex 26-60-5070

Digital Interface Connector:

9 pin D connector, female

Grounding Point:

8-32 ground stud provided on chassis

Dimensions:

20" x 22.5" x 10.75" (508mm x 572mm x 273mm)

Weight:

125lbs (56.7kg)

Orientation:

Can be mounted in any orientation.

X-Ray Leakage:

Not to be greater than 0.5mR/hr at 5cm
outside the external surface

**AC INPUT POWER
J1 6 POSITION TERMINAL BLOCK**

PIN	SIGNAL	PARAMETERS
1	Line	Line
2	Removed	N/C
3	Neutral	Neutral
4	Removed	N/C
5	Spare	N/C
6	Spare	N/C

**ANALOG INTERFACE CONNECTOR—
7 PIN MOLEX, 0.156 CENTER**

PIN	SIGNAL	PARAMETERS
1	X-Ray	+12Vdc @16mA = enable X-Ray
2	X-Ray Return	X-Ray Return
3	N/C	N/C
4	kV Monitor Output	0 to 1.6Vdc = 0 to 160kV
5	SGND	Signal Ground
6	mA Monitor Output	0 to 3Vdc = 0 to 3mA
7	Fault	Open Collector, Open = No Fault

**RS-232 DIGITAL INTERFACE—
9 PIN FEMALE D CONNECTOR**

PIN	SIGNAL	PARAMETERS
1	N/C	No Connection
2	TX	Transmit Data
3	RX	Receive Data
4	N/C	No Connection
5	SGND	Signal Ground
6	N/C	No Connection
7	N/C	No Connection
8	X-Ray Enable	+12Vdc @ 16mA = Enable
9	N/C	No Connection

DIMENSIONS: in.[mm]

TOP VIEW

SIDE VIEW

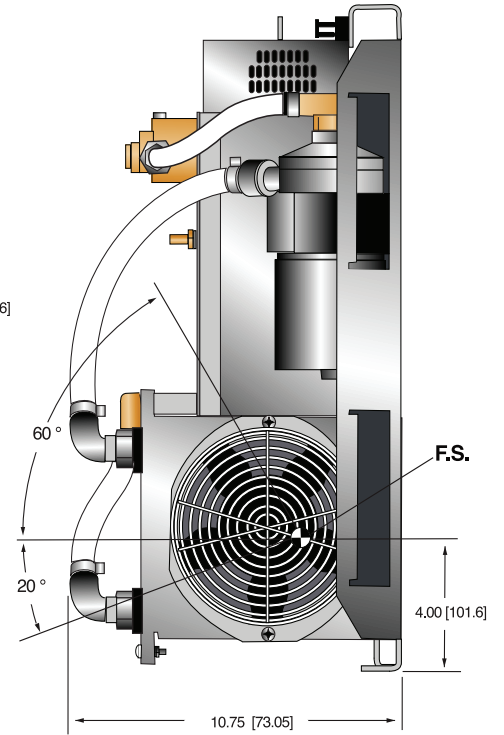
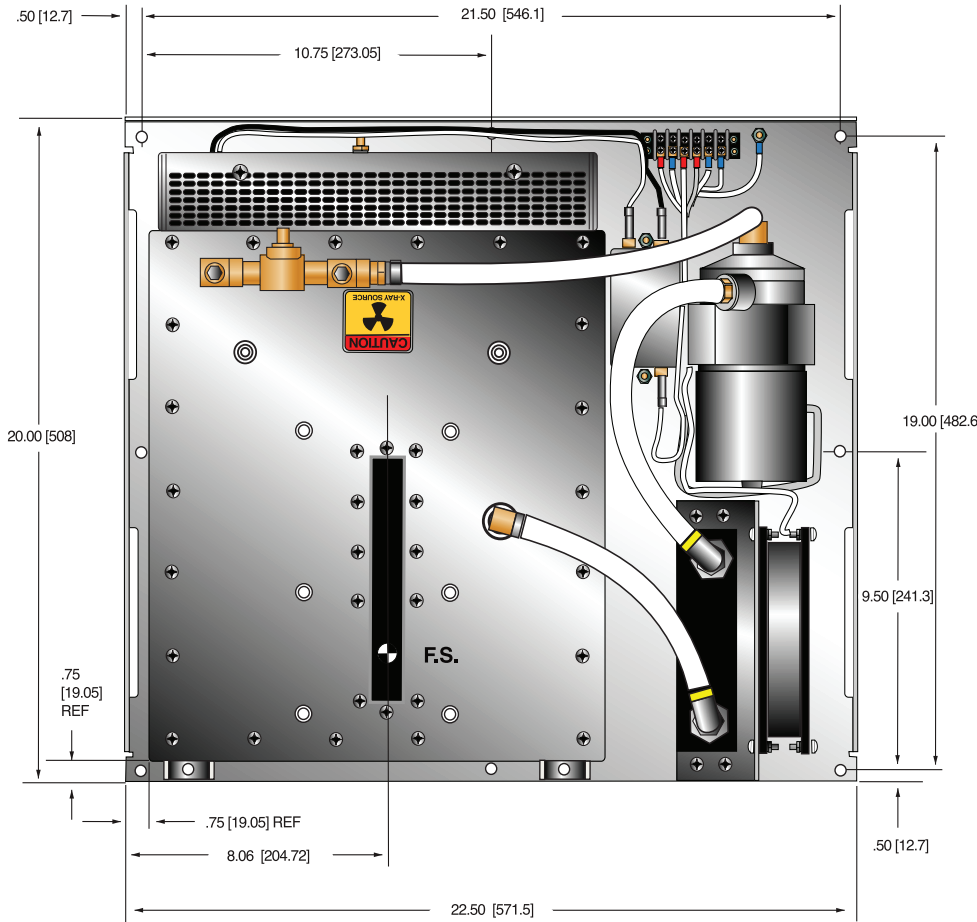

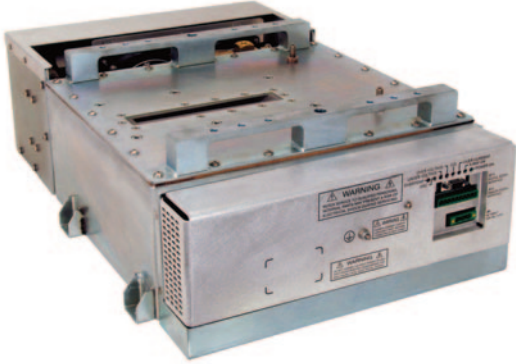

Spellman's XRB160PN480/2 Monoblock® X-Ray source is designed for OEM applications powering its internal X-Ray tube up to 160kV at 480W. Features like universal input, small package size and a standard analog and RS-232 digital interface simplify integrating this Monoblock® into your X-Ray system. Standard models are available with fan shaped beam geometry. Proprietary emission control circuitry provides excellent regulation of X-Ray tube current, along with outstanding stability performance.

TYPICAL APPLICATIONS

X-Ray Scanning: Food Inspection, Fill Level Confirmation and Security Applications

SPECIFICATIONS

X-Ray Characteristics:

Tube Type: Glass tube, Tungsten target, Be filter
Focal Spot: 0.8mm x 0.8mm (IEC336)
Beam Filter: 1mm curved window
Beam Geometry: Asymmetrical fan 80° x 10° ±2°

Input Voltage:

100-240Vac ±10%, 50/60Hz, 6.5A max; 12Vdc @ 5A

X-Ray Tube Voltage:

Nominal X-Ray tube voltage is adjustable between 80kV to 160kV

X-Ray Tube Current:

0.25mA to 3mA over specified tube voltage range

X-Ray Tube Power:

480W maximum

Voltage Regulation:

Line: ±0.1% for a ±10% input line change of nominal input line voltage
Load: ±0.1% for a 0.3mA to 3mA load change

Voltage Accuracy:

Voltage measured across the X-Ray tube is within ±1% of the programmed value

Voltage Risettime:

Ramp time shall be <1 second from 10% to 90% of rated output

- **Integrated HV Supply, Filament Supply, X-Ray Tube, Beam Port and Control Electronics**
- **Compact & Lightweight**
- **Universal Input, Power Factor Corrected**
- **Can be Mounted in Any Physical Orientation**
- **Analog Control Interface and Standard RS-232 Digital Interface**

Voltage Overshoot:

Within 5% of rated voltage in <10ms

Voltage Ripple:

0.1% pp of rated voltage @ ≤1kHz

Current Regulation:

Line: ±0.1% for a ±10% input line change of nominal input line voltage
Load: ±0.5% @ 80-160kV, 0.3mA to 3mA

Current Accuracy:

Current measured through the X-Ray tube is within ±1% of the programmed value

Current Risettime:

<1 second from 10% to 90% of rated output

Arc Intervention:

4 arcs in 10 seconds with a 200ms quench = Shutdown

Filament Configuration:

Internal high frequency AC filament drive with closed loop filament emission control

Analog Interface:

0 to 10Vdc ground referenced signals

Digital Interface:

RS-232 interface.

Control Software:

A demo GUI for engineering evaluations will be provided for the RS-232 digital interface upon request.

Interlock Signals:

A hardware interlock functions in both analog and digital programming modes.

Operating Temperature:

0°C to +40°C

Storage Temperature:

-40°C to +70°C

Humidity:

95% relative humidity, non-condensing

Cooling:

Heat exchanger w/fan and oil pump, powered from DC input

Input Line Connector:

3 pin, Phoenix Contact 1829167

Analog Interface Connector:

10 pin, Phoenix Contact 1755503

Digital Interface Connector:

9 pin D connector, female

Heat Exchanger Power Connector:

4 pin AMP part no. 206061-1

Grounding Point:

8-32 ground stud provided on chassis

Dimensions:

See outline drawing

Weight:

125lbs (56.7kg)

Orientation:

Can be mounted in any orientation.

X-Ray Leakage:

Not to be greater than 0.5mR/hr at 5cm outside the external surface

**AC INPUT POWER
3 PIN PHOENIX CONTACT**

PIN	SIGNAL	PARAMETERS
1	Line	Line
2	GND	Ground
3	Neutral	Neutral

**DC POWER FOR HEAT DISSIPATION UNIT
4 PIN AMP 206061-1 CONNECTOR**

PIN	SIGNAL	PARAMETERS
1	+12	+12Vdc
2	RTN	Return
3	+12	+12Vdc
4	RTN	Return

**ANALOG INTERFACE—
JB15 10 PIN PHOENIX CONTACT**

PIN	SIGNAL	PARAMETERS
1	X-Ray Signal	+24Vdc =Enable X-Ray, 0Vdc/open = Disable X-Ray, Zin=2.2kΩ
2	X-Ray Signal Return	Signal Return
3	N/C	N/C
4	kV Monitor	0-10Vdc = 0 to 178kV, Zout = 10kΩ
5	Signal Ground	Signal Ground
6	mA Monitor	0-10Vdc = 0 to 3.4mA, Zout = 10kΩ
7	Fault Signal	Open collector, High (Open) = No Fault, 35Vdc @10mA maximum
8	HV ON Lamp Relay n/o	Relay Normally Open, 50Vdc @ 1A maximum
9	HV ON Lamp Relay common	Relay Common, 50Vdc @ 1A maximum
10	HV ON Lamp Relay n/c	Relay Normally Closed ,50Vdc @ 1A maximum

LED INDICATORS

INDICATOR	SIGNAL NAME	CONDITION Illuminated When...
LED 1	OT	Over temperature occurs
LED 2	ARC FLT	Arc fault occurs
LED 3	UV	Low kV occurs
LED 4	OV	High kV occurs
LED 5	UC	Low mA occurs
LED 6	OC	High mA occurs
LED 7	X-RAY ON	X-Rays are enabled
LED 8	PWR	Power is ON

**RS-232 DIGITAL INTERFACE—
9 PIN FEMALE D CONNECTOR**

PIN	SIGNAL	PARAMETERS
1	N/C	No Connection
2	Transmit Data	Conforms to E/A RS-232-C
3	Receive Data	Conforms to E/A RS-232-C
4	N/C	No Connection
5	SGND	Signal Ground
6	N/C	No Connection
7	N/C	No Connection
8	N/C	No Connection
9	N/C	No Connection

DIMENSIONS: in. [mm]

FRONT VIEW

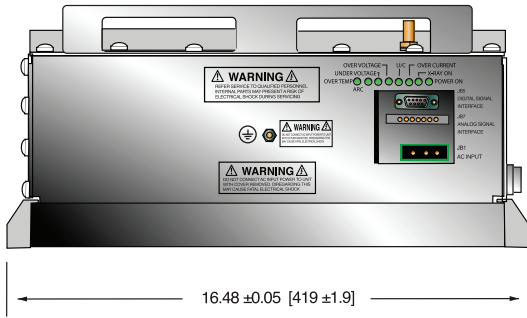

BACK VIEW

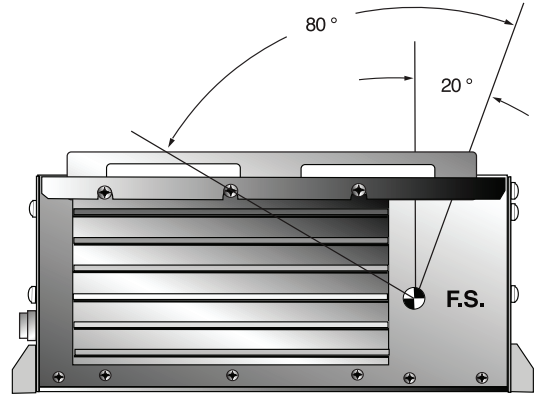

TOP VIEW

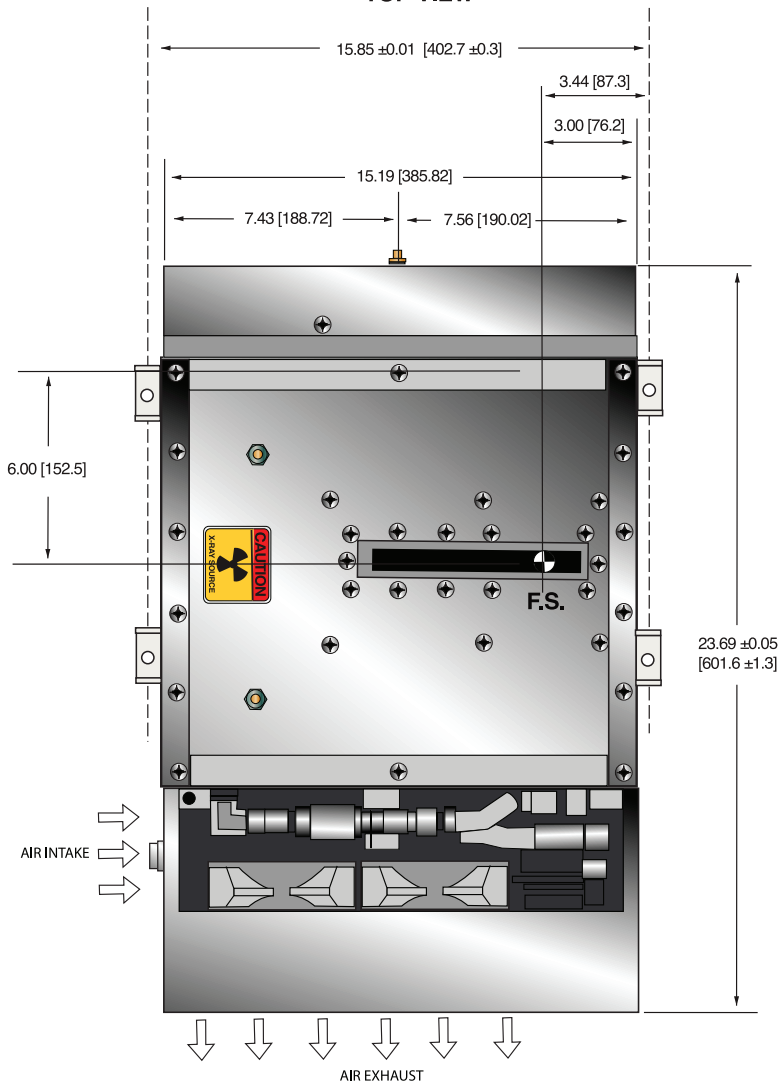

SIDE VIEW

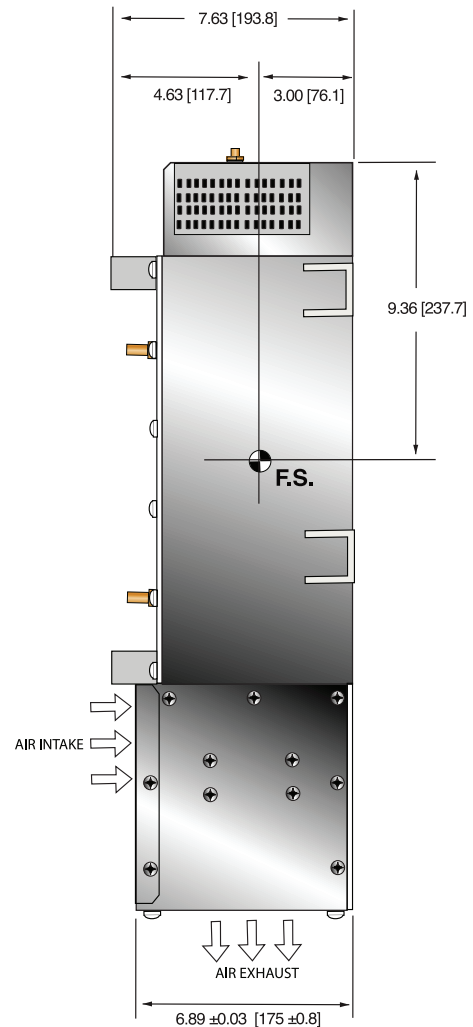



- **Integrated HV Supply, Filament Supply, X-Ray Tube, Beam Port and Control Electronics**
- **Compact & Lightweight**
- **Can be Mounted in Any Physical Orientation**
- **Standard RS-232 Digital Interface**

Spellman's XRB160PN480/CT Monoblock® X-Ray source is designed for OEM applications powering its internal X-Ray tube up to 160kV at 480W. Features like small package size and RS-232 digital interface simplify integrating this Monoblock® into your X-Ray system. Standard models are available with fan shaped beam geometry. Proprietary emission control circuitry provides excellent regulation of X-Ray tube current, along with outstanding stability performance.

TYPICAL APPLICATIONS

X-Ray Scanning: Food Inspection, Fill Level Confirmation and Security Applications

SPECIFICATIONS

X-Ray Characteristics:

Tube Type: Glass tube, Tungsten target, Be filter
Focal Spot: 0.8mm x 0.8mm (IEC336)
Beam Filter: 1.7mm of glass, 1mm of Al, and 10mm of oil
Beam Geometry: Symmetrical fan 105° ±3° x 4° ±1°

Input Voltage:

Monoblock®: 100-240Vac ±10%, 50/60Hz, 6.5A max
Heat Dissipation Unit: 24Vdc, 3A

X-Ray Tube Voltage:

Nominal X-Ray tube voltage is adjustable between 20kV to 160kV

X-Ray Tube Current:

0.3mA to 6mA over specified tube voltage range

X-Ray Tube Power:

320W continuous, 480W peak

Voltage Regulation:

Line: ±0.1% for a ±10% input line change of nominal input line voltage
Load: ±0.1% for a 0.3mA to 6mA load change

Voltage Accuracy:

Voltage measured across the X-Ray tube is within ±1% of the programmed value

Voltage Risetime:

Ramp time shall be <1 second from 1% to 90% of rated output

Voltage Overshoot:

Within 5% of rated voltage

Voltage Ripple:

0.1% pp of rated voltage @ ≤1kHz

Current Regulation:

Line: ±0.5%
Load: ±0.5%

Current Accuracy:

Current measured through the X-Ray tube is within ±1% of the programmed value

Current Risetime:

<1 second from 1% to 90% of rated output

Arc Intervention:

4 arcs in 10 seconds = Shutdown

Filament Configuration:

Internal high frequency AC filament drive with closed loop filament emission control

Digital Interface:

RS-232

Control Software:

A demo GUI for engineering evaluations will be provided for the RS-232 digital interface upon request.

Interlock Signals:

A hardware interlock functions in digital programming modes.

Operating Temperature:

0°C to +40°C

Storage Temperature:

-40°C to +70°C

Humidity:

5% to 90% relative humidity, non-condensing

Cooling:

Heat exchanger w/fan and oil pump, powered from customer provided 24Vdc @ 3A

Input Line Connector:

3 pin Phoenix Contact part no. 1829167

Digital Interface Connector:

9 pin D, female

Analog Signal Connector:

10 pin Phoenix Contact part no. 1755503

Cooler Power Connector:

4 pin AMP part no. 206061-1

Grounding Point:

8-32 ground stud provided on chassis

Dimensions:

24.00" x 16.00" x 6.50"
(609.60mm x 406.40mm x 165.10mm)

Weight:

125lbs (49.5kg) ±10lbs (±4.5kg)

Orientation:

Can be mounted in any orientation.

X-Ray Leakage:

Not to be greater than 0.5mR/hr at 5cm outside the external surface

Special Features:

Stationary or rotating CT application up to 90rpm at a max. radius of 24.75" (629mm)

**AC INPUT POWER
3 PIN PHOENIX CONTACT**

PIN	SIGNAL	PARAMETERS
1	Line	Line
2	GND	Ground
3	Neutral	Neutral

**ANALOG INTERFACE—
10 PIN PHOENIX CONTACT**

PIN	SIGNAL	PARAMETERS
1	X-Ray	+24Vdc = enable X-Ray
2	X-Ray Return	X-Ray Return
3	N/C	No Connection
4	kV Monitor Output	0 to 9Vdc = 0 to 100% Rated Voltage
5	SGND	Signal Ground
6	mA Monitor Output	0 to 9Vdc = 0 to 100% Rated Current
7	Fault	Open Collector, Open = No Fault
8	Relay N/C	HV On, 50V @ 1A maximum
9	Relay Common	HV On, 50V @ 1A maximum
10	Relay N/O	HV On, 50V @ 1A maximum

**RS-232 DIGITAL INTERFACE—
9 PIN FEMALE D CONNECTOR**

PIN	SIGNAL	PARAMETERS
1	N/C	No Connection
2	Transmit Data	Conforms to E/A RS-232-C
3	Receive Data	Conforms to E/A RS-232-C
4	N/C	No Connection
5	SGND	Signal Ground
6	N/C	No Connection
7	N/C	No Connection
8	N/C	No Connection
9	N/C	No Connection

DIMENSIONS: in.[mm]

FRONT VIEW

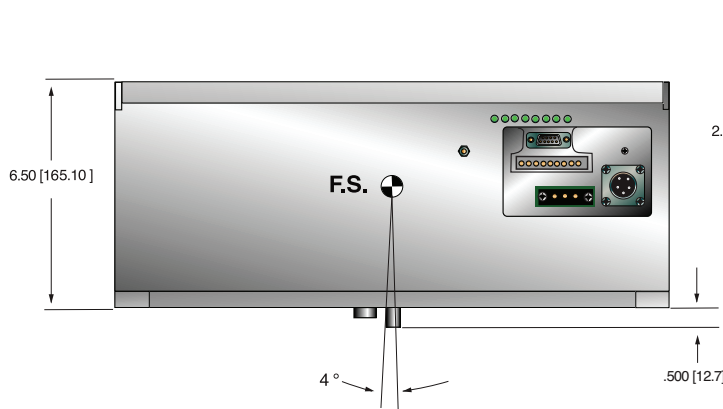

BACK VIEW

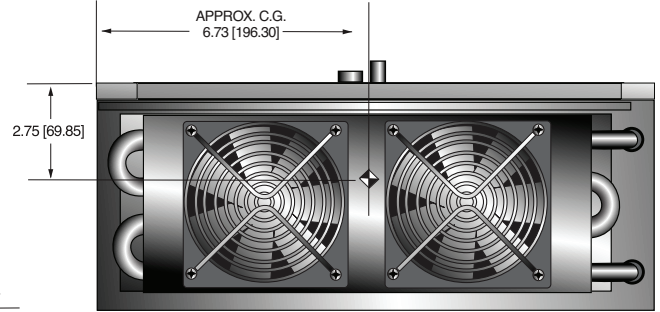

TOP VIEW

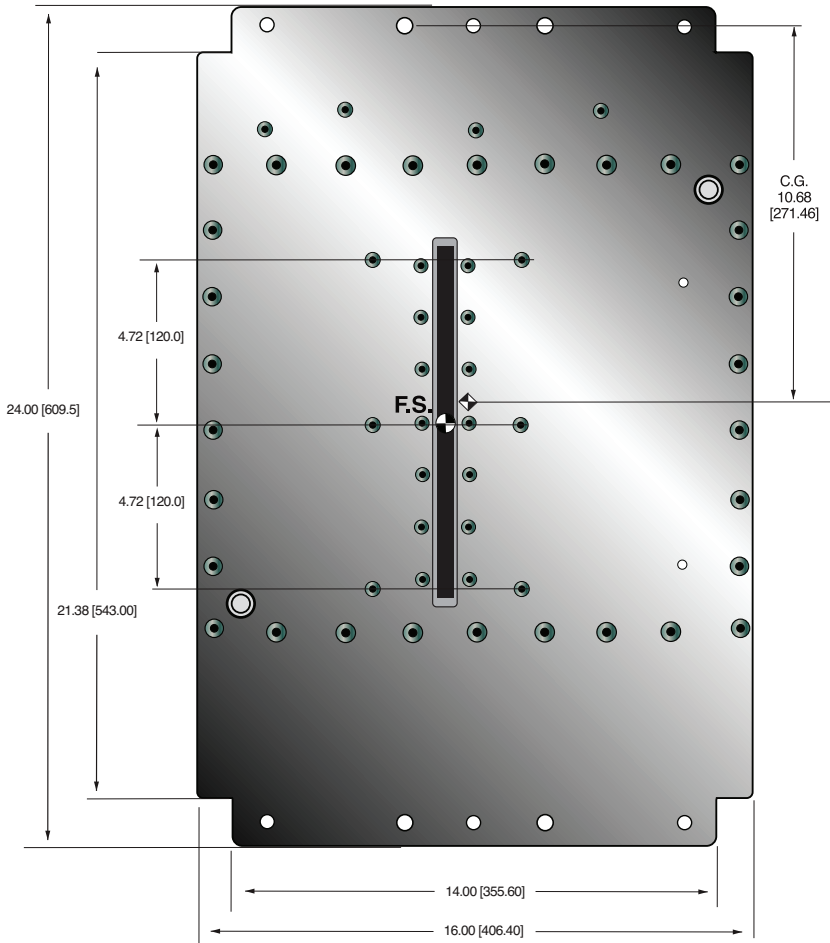

SIDE VIEW

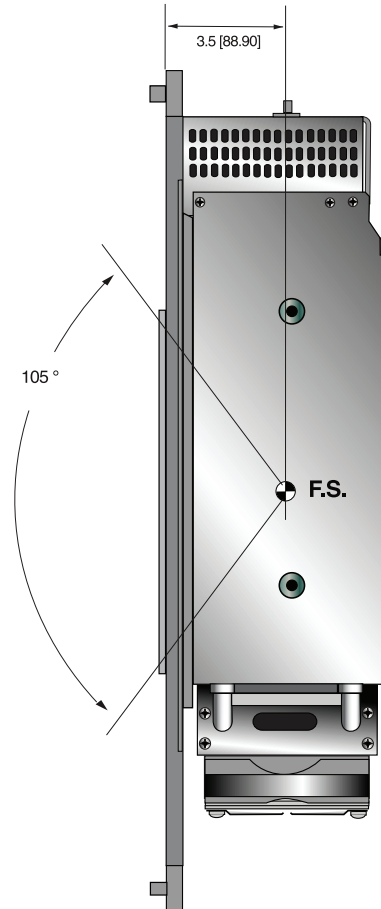



- **Integrated HV Supply, Filament Supply, X-Ray Tube, Beam Port and Control Electronics**
- **Compact & Lightweight**
- **Power Factor Corrected**
- **Can be Mounted in Any Physical Orientation**
- **Analog Monitoring and Standard RS-232 Digital Interface**

Spellman's XRB150PN600 Monoblock® X-Ray source is designed for OEM applications powering its internal X-Ray tube up to 150kV at 600W. Features like power factor correction, small package size and a standard analog and RS-232 digital interface simplify integrating this unit into your X-Ray system. Standard models are available with cone shaped beam geometry. Proprietary emission control circuitry provides excellent regulation of X-Ray tube current, along with outstanding stability performance.

TYPICAL APPLICATIONS

X-Ray Scanning: Bone Densitometry,
Food Inspection, Security

SPECIFICATIONS

X-Ray Characteristics:

Tube Type: Glass tube, Tungsten target, Be filter
Focal Spot: 0.5mm x 0.5mm (IEC 336)
Beam Filter: 0.06" Ultem
Beam Geometry: Cone, 18° ±1°

Input Voltage:

200-240Vac ±10%, 50/60Hz, 6.5A maximum

X-Ray Tube Voltage:

Nominal X-Ray tube voltage is adjustable between
70kV to 150kV

X-Ray Tube Current:

1.0mA to 4.0mA over specified tube voltage range

X-Ray Tube Power:

160W continuous, 600W peak
Duty Cycle: 30 seconds on, 300 seconds off
@ 600W peak

Voltage Regulation:

Line: ±0.1% for a ±10% input line change of
180 to 264Vac
Load: ±0.1% for a 1.0mA to 4.0mA load change.
600W maximum

Voltage Accuracy:

Voltage measured across the X-Ray tube is within
±2% of the programmed value

Voltage Risetime:

±1% in less than 300ms

Voltage Overshoot:

±10% during 300ms risetime

Voltage Ripple:

1% rms of rated voltage @ 10Hz to 1MHz

Current Regulation:

Line: ±0.1% from 180-264Vac
Load: ±0.5% @ 70kV-150kV, 1.0mA to 4.0mA

Current Accuracy:

Current measured through the X-Ray tube is within
±2% of the programmed value

Current Risetime:

±1% in less than 300ms

Arc Intervention:

4 arcs in 10 seconds with a 200ms quench = Shutdown

Filament Configuration:

Internal high frequency AC filament drive with closed loop
filament emission control

Analog Interface:

0 to 5Vdc ground referenced signals

Digital Interface:

RS-232 interface.

Control Software:

A demo GUI for engineering evaluations will be provided
for the RS-232 digital interface upon request.

Interlock/Signals:

A hardware interlock function is provided

Operating Temperature:

0°C to +40°C

Storage Temperature:

-40°C to +70°C

Humidity:

10% to 95% relative humidity, non-condensing

Cooling:

External fan required. 250cfm minimum to maintain
an oil temperature of 55° C

Input Line Connector:

3 pin Phoenix Contact P/N 1829167

Analog Interface Connector:

10 pin Phoenix Contact P/N 1755503

Digital Interface Connector:

9 pin D connector, female

Grounding Point:

8-32 ground stud provided on chassis

Dimensions:

13.46" x 13.38" x 6.24"
(341.89mm x 339.85mm x 158.50mm)

Weight:

66lbs (30kg)

Orientation:

Can be mounted in any orientation.

X-Ray Leakage:

Less than 100mR/hr at 1m distance,
measured at 140kV, 3mA

**AC INPUT POWER
JB1 3 PIN PHOENIX CONTACT**

PIN	SIGNAL	PARAMETERS
1	Line	Line
2	GND	Chassis Ground
3	Neutral	Neutral

**RS-232 DIGITAL INTERFACE—
JB16 9 PIN FEMALE D CONNECTOR**

PIN	SIGNAL	PARAMETERS
1	Spare	N/C
2	Transmit	RS-232
3	Receive	RS-232
4	Spare	N/C
5	Signal Ground	Ground
6	Spare	N/C
7	Spare	N/C
8	Spare	N/C
9	Spare	N/C

**ANALOG INTERFACE—
JB15 10 PIN PHOENIX CONTACT**

PIN	SIGNAL	PARAMETERS
1	X-Ray Signal	+ 12Vdc =Enable X-Ray, 0Vdc/open = Disable X-Ray, Zin=1kΩ
2	X-Ray Signal Return	Signal Return
3	N/C	N/C
4	kV Monitor	0 to 5Vdc = 0 to 175kV, Zout= 10kΩ
5	Signal Ground	Signal Ground
6	mA Monitor	0 to 5Vdc = 0 to 4.5mA, Zout= 10kΩ
7	Fault Signal	Open collector, High (Open) = No Fault, 35Vdc @10mA maximum
8	HV ON Lamp Relay n/o	Relay Normally Open, 50Vdc @ 1A maximum
9	HV ON Lamp Relay common	Relay Common, 50Vdc @ 1A maximum
10	HV ON Lamp Relay n/c	Relay Normally Closed, 50Vdc @ 1A maximum

LED INDICATORS

INDICATOR	SIGNAL NAME	CONDITION Illuminated When...
LED 1	OT	Over temperature occurs
LED 2	ARC FLT	Arc fault occurs
LED 3	UV	Low kV occurs
LED 4	OV	High kV occurs
LED 5	UC	Low mA occurs
LED 6	OC	High mA occurs
LED 7	X-RAY ON	X-Rays are enabled
LED 8	PWR	Power is ON

DIMENSIONS: in.[mm]

FRONT VIEW TANK

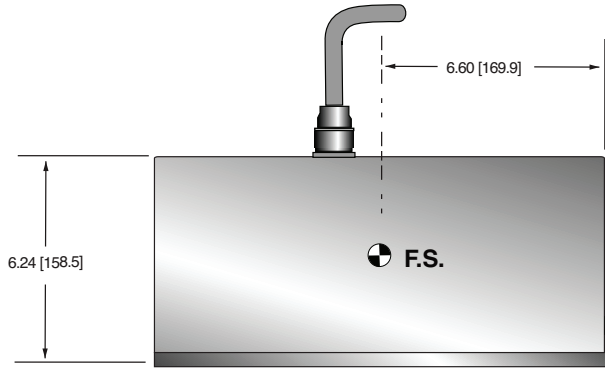

FRONT VIEW CONTROL ASSEMBLY

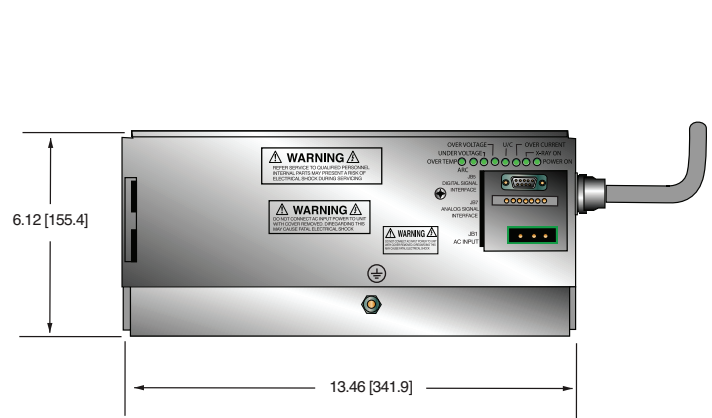

SIDE VIEW TANK

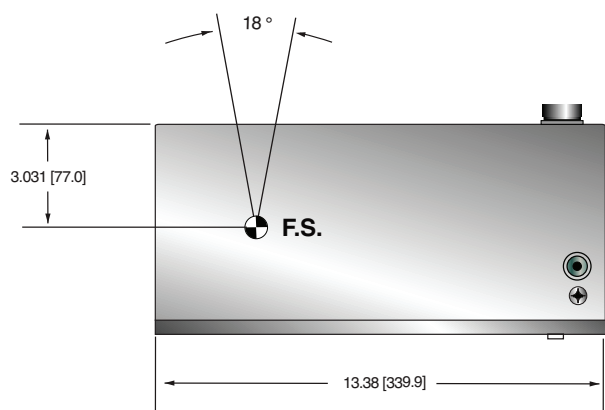

SIDE VIEW CONTROL ASSEMBLY

AIR EXHAUST

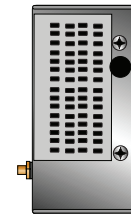

TOP VIEW TANK

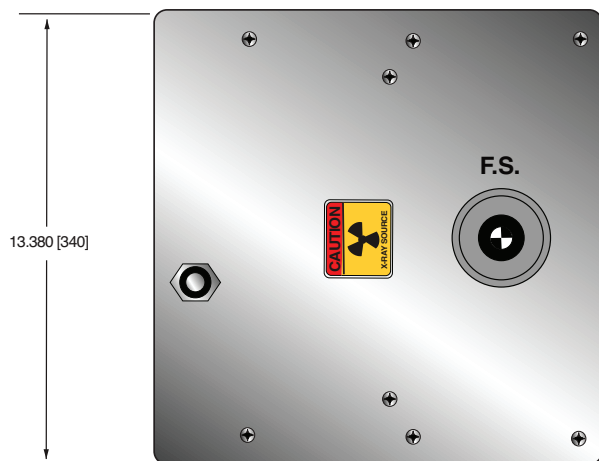

SIDE VIEW CONTROL ASSEMBLY

AIR INTAKE

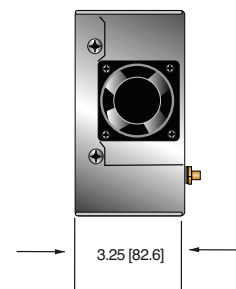



- **Integrated HV Supply, Filament Supply, X-Ray Tube, Beam Port and Control Electronics**
- **Compact & Lightweight**
- **Power Factor Corrected**
- **Can be Mounted in Any Physical Orientation**
- **Standard RS-232 Digital Interface**

Spellman's XRB160PN688/CT Monoblock® X-Ray source is designed for OEM applications powering its internal X-Ray tube up to 160kV at 688W. Features like small package size and RS-232 digital interface simplify integrating this unit into your X-Ray system. Proprietary emission control circuitry provides excellent regulation of X-Ray tube current, along with outstanding stability performance.

TYPICAL APPLICATIONS

X-Ray Scanning: Food Inspection, Fill Level Confirmation and Security Applications

SPECIFICATIONS

X-Ray Characteristics:

Tube Type: Glass tube, Tungsten target, Be filter
Focal Spot: 2.5mm x 2.5mm (IEC 60336)
Beam Filter: 1.5mm glass, 9-26mm oil, 0.4mm Al
Beam Geometry: Asymmetrical fan 93° x 15° ±2°

Input Voltage:

230Vac, ±15%, 50/60Hz, 5A max

X-Ray Tube Voltage:

Nominal X-Ray tube voltage is adjustable between 50kV to 160kV

X-Ray Tube Current:

0.25mA to 4.3mA over specified tube voltage range

X-Ray Tube Power:

688W maximum continuous

Voltage Regulation:

Line: ±0.1% ±10%
Load: ±0.1% 0.25 to 4.3mA

Voltage Accuracy:

Voltage measured across the X-Ray tube is within 1% of the programmed value

Voltage Risetime:

Ramp time shall be 500ms nominal, 1 second maximum from 10% to 90% of rated output

Voltage Overshoot:

Within 5% of rated voltage

Voltage Ripple:

1% p-p of rated voltage

Current Regulation:

Line: ±0.5% ±10%
Load: ±0.5% 0.25 to 4.3mA

Current Accuracy:

Current measured through the X-Ray tube is within 5% of the programmed value

Current Risetime:

500ms nominal, 1 second maximum

Arc Intervention:

4 arcs in 10 seconds = shutdown

Filament Configuration:

Internal high frequency AC filament drive with closed loop filament emission control

Digital Interface:

RS-232 interface.

Control Software:

A demo GUI for engineering evaluations will be provided for the RS-232 digital interface upon request.

Interlock Signals:

A hardware interlock function is provided

Operating Temperature:

5°C to +40°C

Storage Temperature:

-25°C to +65°C

Humidity:

10% to 90% relative humidity, non-condensing

Cooling:

Heat exchanger w/fan and oil pump, powered from AC

Input Line Connector:

5 pin Molex 26-60-4050

Heat Exchanger Power Connector:

4 pin AMP part no. 206061-1

Digital Interface Connector:

9 pin D connector, female

Grounding Point:

M5 ground stud provided on chassis

Dimensions:

See drawing

Weight:

140lbs ±10lbs (64kg ±4.5kg)

Orientation:

Can be mounted in any orientation.

X-Ray Leakage:

Less than 300uR/hr at a distance of 10cm from all surfaces

Special Features:

Stationary or rotating CT application up to 100rpm at a maximum radius 20.25" (514mm)

**AC INPUT POWER
J1 5 PIN MOLEX 26-60-4050 CONNECTOR**

PIN	SIGNAL	PARAMETERS
1	Line	230Vac Input
2	Line	230Vac Input
3	N/C	No Connection
4	Neutral	230Vac Neutral
5	Neutral	230Vac Neutral

**AC POWER FOR HEAT DISSIPATION UNIT
4 PIN AMP 206061-1 CONNECTOR**

PIN	SIGNAL	PARAMETERS
1	Line	230Vac Input
2	N/C	No Connection
3	Neutral	230Vac Neutral
4	GND	Chassis Ground

**RS-232 DIGITAL INTERFACE—
J5 9 PIN FEMALE D CONNECTOR**

PIN	SIGNAL	PARAMETERS
1	N/C	No Connection
2	TX	Transmit Data
3	RX	Receive Data
4	N/C	No Connection
5	SGND	Signal Ground
6	N/C	No Connection
7	N/C	No Connection
8	N/C	No Connection
9	N/C	No Connection

DIMENSIONS: in.[mm]

TOP VIEW

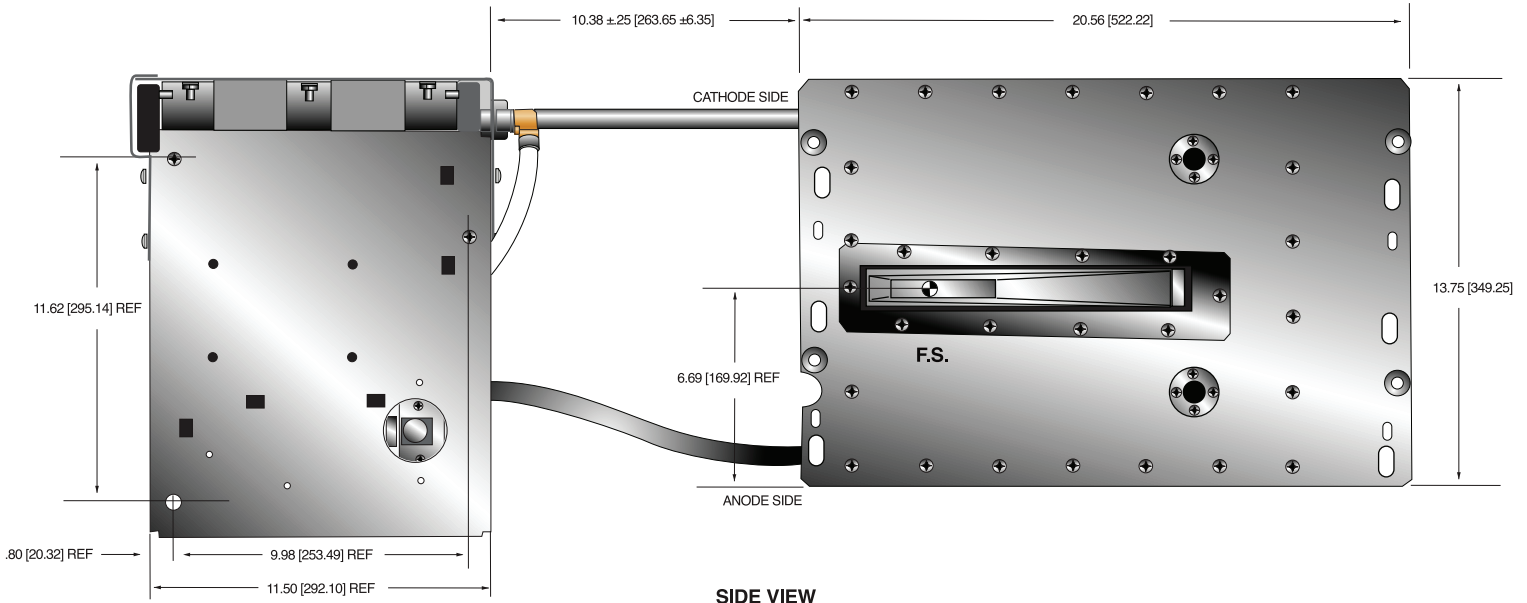

SIDE VIEW

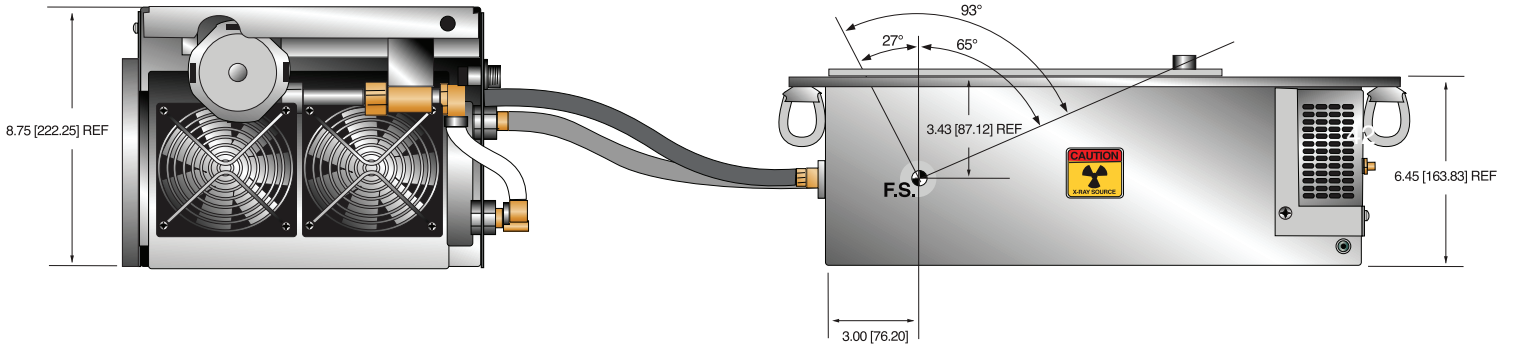

BOTTOM VIEW

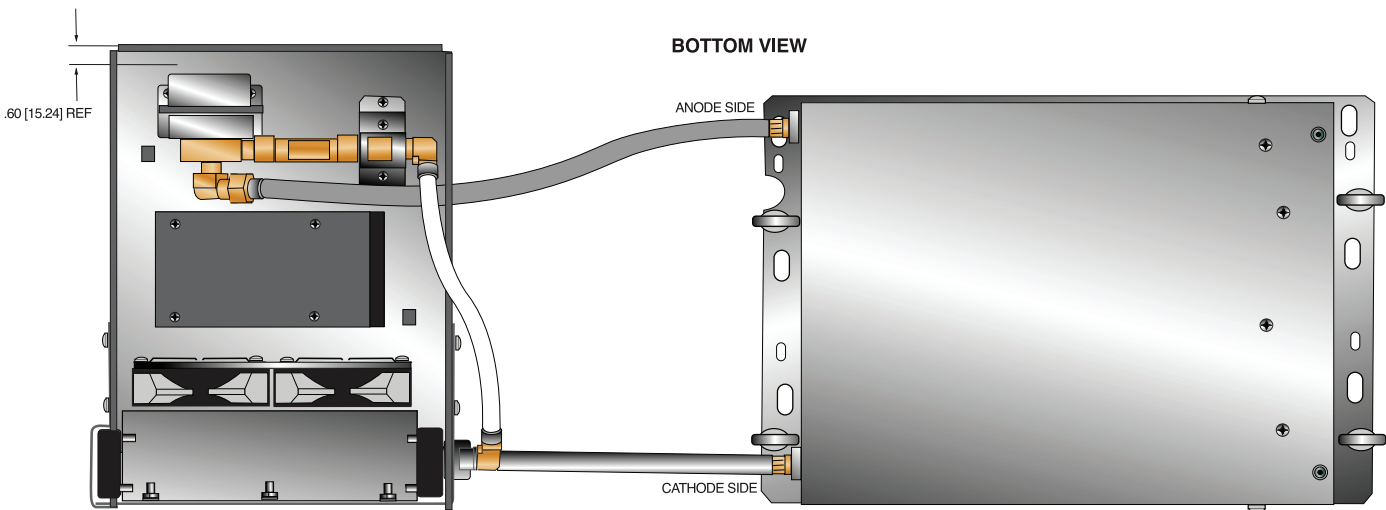



- **Integrated HV Supply, Filament Supply, X-Ray Tube, Beam Port and Control Electronics**
- **Compact & Lightweight**
- **Analog or Digital Control Interface**

Spellman's new Panoramic Dental Monoblock® consists of an integrated X-Ray tube, dual-output high voltage power supply, and filament supply with control circuitry. The PDM90PN900 is designed for extra oral dental X-Ray applications including CT and Panoramic X-Ray. Features like small package size, standard analog and RS-232 digital interface simplify integrating this Monoblock® into your X-Ray system. Proprietary emission control circuitry provides excellent regulation of X-Ray tube current, along with outstanding stability and performance.

TYPICAL APPLICATIONS

Dental X-Ray: Panoramic and CT Imaging

SPECIFICATIONS

X-Ray Tube Characteristics:

Target Angle: 5 degrees
Focal Spot: 0.5mm nominal
Beam Filtration: 3.0mm of Al equivalent
Beam Geometry: see page 3

X-Ray Tube Voltage:

Nominal X-Ray tube voltage is adjustable between 50kV to 90kV

Voltage Regulation:

Line: $\pm 0.5\%$ for a $\pm 1V$ change of nominal input line voltage
Load: $\pm 0.1\%$ for a load change of 25 μA to maximum rated current

X-Ray Tube Current:

1mA to 10mA over specified tube voltage range

Current Regulation:

Line: $\pm 0.5\%$ for a $\pm 1V$ change of nominal input line voltage
Load: $\pm 0.5\%$ for a voltage change of 35kV to 80kV

X-Ray Tube Power:

900W peak power

Duty Cycle:

CT (Pulsed): ≤ 45 seconds scan time cycle at up to 40 pulses per second available

Panoramic (Continuous): Maximum scan time = 30s, with 60s off-time. Five consecutive scans

Input Voltage:

100-240Vac $\pm 10\%$ 50/60 Hz, 10 amps RMS maximum

Interface:

The RS-232 serial communications interface will be used to program and monitor output voltage and current, control various functions and report status and faults.

Digital Interface Connector:

RS-232: 9 pin D connector, male

Operating Temperature:

0°C to +40°C

Storage Temperature:

-20°C to +70°C

Humidity:

5% to 95% relative humidity, non-condensing

Cooling:

Tank: Convection
Controller: Forced air via provided fan

Dimensions:

X-Ray Tank: 9.7"W x 7.7"H x 4.7"D
(247mm x 195mm x 119mm)
Inverter/Controller: 7.10"W x 9.80"H x 3.60"D
(180mm x 250mm x 92mm)

Weight:

X-Ray Tank: 17lbs (7.7kg)
Inverter/Controller: 6.5lbs (3kg)

X-Ray Leakage:

Less than 100mR/hour (or $< 1mGy/hr$) @ 1meter from the Monoblock® surface.

Regulatory Approvals:

Compliant to EMC 60601-1-2 (external EMC filter and shielding required). UL/CUL recognized file E242584.

AC INPUT POWER 3 PIN PHOENIX CONTACT

PIN	SIGNAL	PARAMETERS
1	Line	Line
2	GND	Ground
3	Neutral	Neutral

ANALOG INTERFACE— J2 10 PIN PHOENIX CONTACT

PIN	SIGNAL	PARAMETERS
1	X-Ray Ready/Sync	+5 V Logic
2	X-Ray Enable	+5 V Logic
3	+ X-ray Signal (Exgate)	+5VDC = Enable X-Ray, Low (or Open) = Disable X-Ray
4	Signal Ground	Signal Ground
5	VMTR Signal (KV monitor)	Voltage: 0 to +5.00 V max, Scale Factor: 0 – 5.00 Vdc = 0 to 100 kV
6	Signal Ground	Signal Ground
7	IMTR Signal (mA monitor)	Voltage: 0 to +5.00 V max, Scale Factor: 0 – 5.00 Vdc = 0 – 12.1mA
8	Fault Signal	Output signal: Open Collector, High (Open) = No Fault
9	HV ON Lamp, Relay N/O	Relay Normally Open, Dry contacts rated 1A or less will handle a nominal 50mA DC load.
10	HV ON Lamp, Common	Common

RS-232 DIGITAL INTERFACE— J5 9 PIN MALE D CONNECTOR

PIN	SIGNAL	PARAMETERS
1	N/C	No Connection
2	TX	Transmit Data
3	RX In	Receive Data
4	N/C	No Connection
5	SGND	Signal Ground
6	N/C	No Connection
7	N/C	No Connection
8	N/C	No Connection
9	N/C	No Connection

LED INDICATORS

INDICATOR	SIGNAL NAME	CONDITION Illuminated When...
LED 1	OV	High kV occurs
LED 2	UV	Low kV occurs
LED 3	UC	Low mA occurs
LED 4	OC	High mA occurs
LED 5	ARC FLT	Arc fault occurs
LED 6	OT	Over temperature occurs
LED 7	PW (Pulse mode)	Pulse mode selected
LED 8	CW (CW mode)	CW mode selected
LED 9	CW (CW mode)	X-Ray is ON

PDM Generator Tank

DIMENSIONS: in.[mm]

TOP VIEW

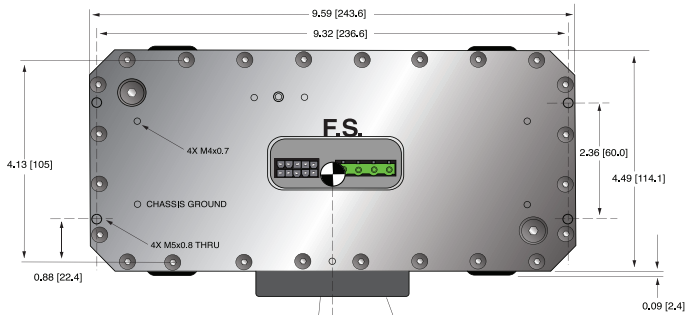

FRONT VIEW

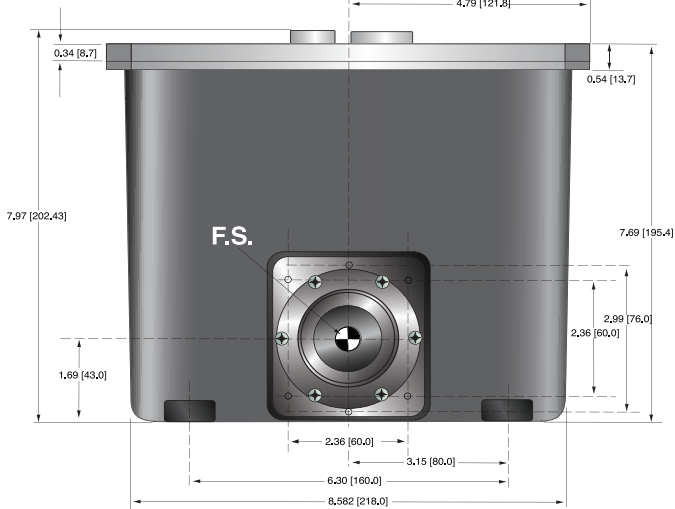

SIDE VIEW

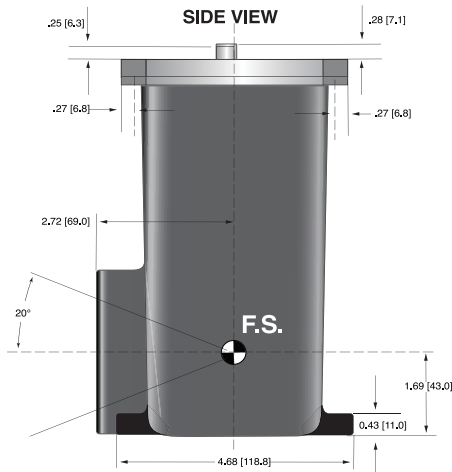

PDM Inverter/Controller

DIMENSIONS: in.[mm]

TOP VIEW

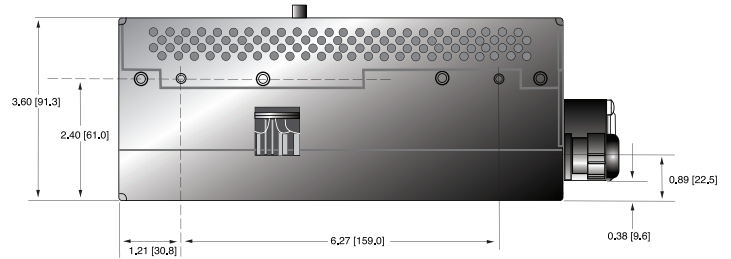

FRONT VIEW

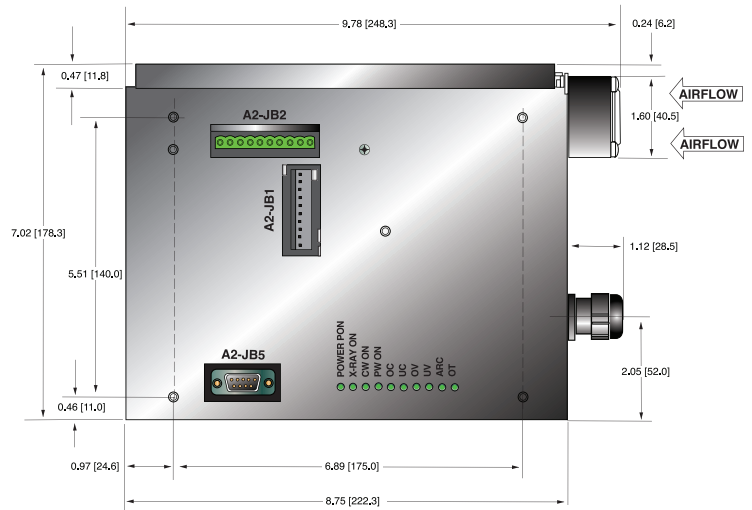

SIDE VIEW

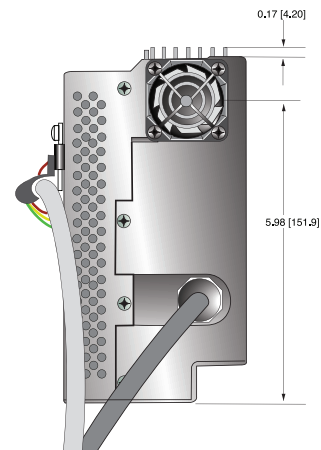



Spellman's ML430 power supply module has been designed specifically to drive high voltage amplifiers. This compact, low cost, SMT based high performance module is printed circuit board mountable. Its dual output is ideal for amplifier driver requirements together with electrostatic lenses, deflectors and biasing supplies.

This voltage regulated, current limited, fixed, dual output unit provides up to 25mA of load current. The ML430 is fully protected against arc and short circuit conditions. The grounded metal case provides both shielding and heat sinking functions. An Enable feature is provided, allowing simple remote operation of the supply.

TYPICAL APPLICATIONS

High Voltage Amplifiers
Electrostatic Lenses

SPECIFICATIONS

Input Voltage:

+24 Vdc, ± 1.2 Vdc

Input Current:

≤ 1.2 amp

Output Voltage:

Output 1-Positive:
+430 volts fixed. Accuracy $\pm 7\%$

Output 2-Negative:
-430 volts fixed. Accuracy $\pm 7\%$

Accuracy specified over full temperature, input voltage and load ranges

Output Current:

12mA maximum – Output 1-Positive
25mA maximum – Output 2-Negative

- **High Voltage Lens Power Supply**
- **Dual Positive and Negative Outputs**
- **Low Cost, Air Insulated Design**
- **SMT Design—Small Size and Low Weight**
- **UL Approved to UL61010-1**
- **Arc and Short Circuit Protected**
- **Remote Enable Control Provided**

Line Regulation: (typical)

$\pm 0.1\%$ – Positive output
 $\pm 1.0\%$ – Negative output

Load/Cross Regulation: (typical)

$\pm 0.1\%$ – Positive output
 $\pm 3.5\%$ – Negative output

Output Current Limit:

An auto-recovering short circuit fold back limit is employed.
Fully arc protected, capable of 10 arcs in 5 seconds.

Ripple:

$\leq 0.5\%$ p-p of full rated output voltage

Stability:

$\leq 0.25\%$ per hour, constant operating conditions after 1 hour warm up

Temperature Coefficient:

≤ 200 ppm per degree C

Environmental:

Temperature Range:
Operating: 0°C to 50°C
Storage: -35°C to 85°C

Humidity:
10% to 90% RH, non-condensing

Cooling:

Unit must be mounted in free air, in any position with the exception of inverted (pins up). Forced air cooling is recommended

Dimensions:

0.984" H X 2.362" W X 2.362" D (25mm x 60mm x 60mm)

Weight:

3.31 oz. (94g)

Regulatory Approvals:

Compliant to EEC EMC Directive. Compliant to EEC Low Voltage Directive. UL/CUL recognized file E227588 & E354595. RoHS compliant.

DIMENSIONS: in.[mm]

TOP VIEW

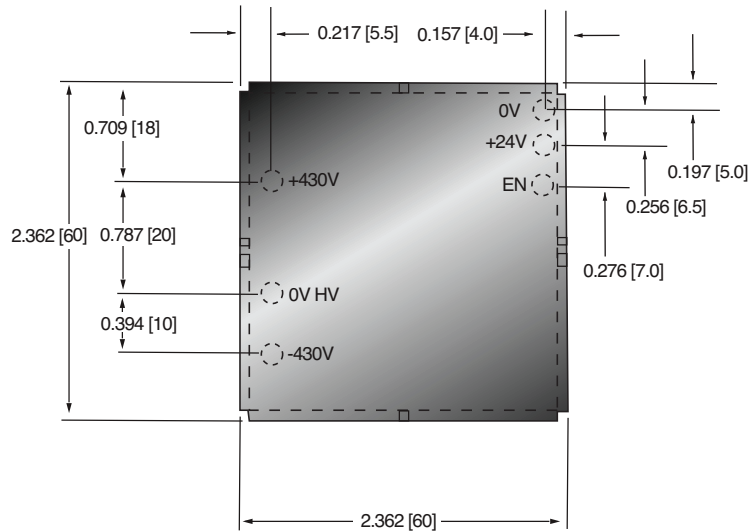

FRONT VIEW

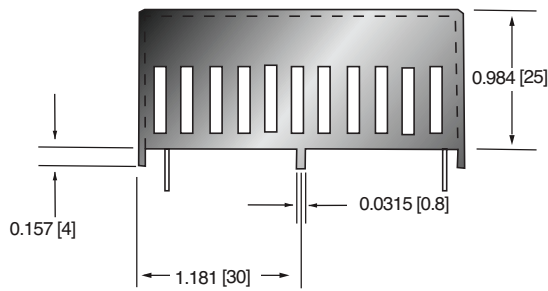

SIDE VIEW

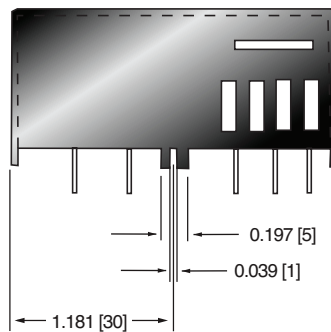

How to Order:
PART NO.: ML430P/N16/24





- **Quad Output High Voltage Power Supply**
- **Low Cost, Air Insulated Design**
- **SMT Design—Small Size and Low Weight**
- **Arc and Short Circuit Protected**
- **Remote Enable Control Provided**
- **UL Approved to UL61010-1**

Spellman's ML1350 power supply module has been designed specifically to drive quadrupoles used in mass spectrometry. This compact, low cost, SMT based high performance module is printed circuit board mountable. This quad output supply is ideal for quadrupole drivers and electrostatic lenses.

This voltage regulated, current limited, fixed quad output unit provides up to 15mA of load current from each output. The ML1350 is fully protected against arc and short circuit conditions. The grounded metal case provides both shielding and heat sinking functions. An Enable feature is provided, allowing simple remote operation of the supply.

TYPICAL APPLICATIONS

Quadrupole HVPS
Electrostatic Lenses

SPECIFICATIONS

Input Voltage:

+24 Vdc, ± 1.2 Vdc

Input Current:

≤ 3.0 amps

Output Voltage:

Output 1-Positive:

+245 volts, fixed, accuracy $< \pm 10\%$

Output 2-Negative:

-245 volts, fixed, accuracy $< \pm 10\%$

Output 3-Positive:

+1350 volts, fixed, accuracy $< \pm 7\%$

Output 4-Negative:

-1350 volts, fixed, accuracy $< \pm 7\%$

Output Current:

15mA maximum for each output

Line Regulation: (typical)

± 1 volt all outputs

Load Regulation: (typical)

$\pm 3\%$ all outputs

Output Current Limit:

An auto-recovering short circuit fold back limit is employed. Fully arc protected, capable of 10 arcs in 5 seconds.

Ripple:

$\leq 0.1\%$ p-p of full rated output voltage

Stability:

$\leq 0.25\%$ per hour, constant operating conditions after 1 hour warm up.

Under Voltage Shutdown:

The power supply will shut down when an input under voltage condition is detected. When the input voltage is restored above 11.8 volts, operating the enable pin will reset this fault.

Temperature Coefficient:

≤ 200 ppm per degree C

Environmental:

Temperature Range:

Operating: 0°C to 50°C

Storage: -35°C to 85°C

Humidity:

10% to 90% RH, non-condensing

Cooling:

Unit must be mounted in free air, in any position with the exception of inverted (pins up). Forced air cooling is recommended.

Dimensions:

0.984" H X 4.331" W X 3.150" D (25mm x 110mm x 80mm)

Width does not include mounting tab

Weight:

7.27 oz. (206g)

Regulatory Approvals:

Compliant to EEC EMC Directive. Compliant to EEC Low Voltage Directive. UL/CUL recognized file E227588 & E354595. RoHS compliant.

DIMENSIONS: in.[mm]

TOP VIEW

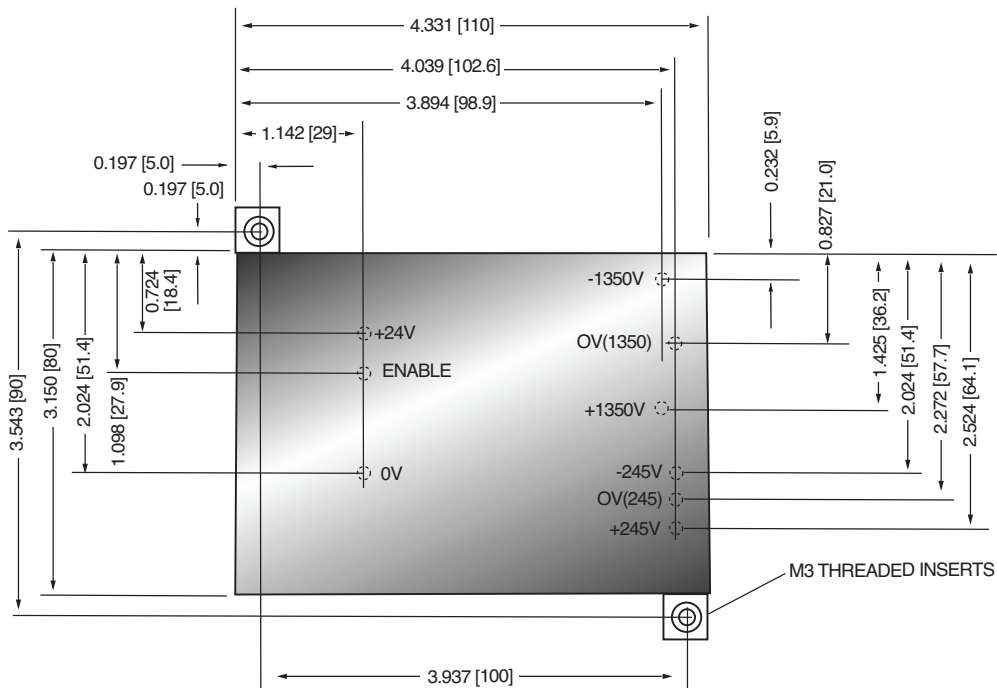

FRONT VIEW

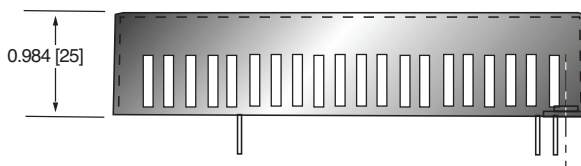

SIDE VIEW

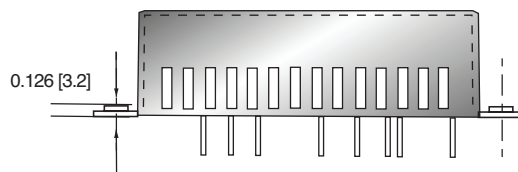

How to Order:
PART NO.: ML1350P/N50/24





- **Floating, Programmable 3kV Output**
- **Output Isolated to 15kV**
- **Well Regulated, Low Ripple**
- **Output Voltage Monitor**
- **Compact Shielded Metal Enclosure**
- **Arc and Short Circuit Protected**

Spellman's MCP Module is a well-regulated, high performance DC-DC converter featuring a floating 3kV output, isolated to 15kV. The MCP low output ripple specification makes it ideal for use with detectors in Mass Spectrometry applications like: Electron Multipliers (EM's), Microchannel Plates Detectors (MCP's) and Channel Electron Multipliers.

This +3kV @ 330uA module is packaged in a shielded metal enclosure. The unit has remote voltage programming and a voltage monitor, and features low injected ripple when used with biasing supplies. The MCP module is easily customized to meet OEM requirements with improved ripple performance, improved stability and configurable output lead terminations as required.

TYPICAL APPLICATIONS

Mass Spectrometry Detectors
Microchannel Plates
Electron Multipliers
Channel Electron Multipliers

SPECIFICATIONS

Input Voltage:

+24Vdc, ± 0.5 volts

Input Current:

600 mA maximum

Output Voltage:

+100V to +3kV, continuously variable over the entire output range

Output Current:

330uA maximum

Polarity:

Positive

Isolation Voltage:

Up to 15kV total to ground
(resistance to ground 600M on each output)

Line Regulation:

$\leq 0.01\%$ for input voltage change of 1V

Load Regulation:

$\leq 0.1\%$ for a no load to full load change

Voltage Programming:

0 to 10 volt corresponds to 0 to 100% of rated output voltage

Voltage Monitor:

0 to 5 volts corresponds to 0 to 100% of rated output voltage

Accuracy:

$\pm 1\%$ from 10% to 100% of output.
Below 10% accuracy spec is not guaranteed

Ripple:

$\leq 0.1\%$ Volts p-p, 0.1Hz to 1MHz

Stability:

≤ 1000 ppm/hour at constant operating conditions
after a 1 hour warm up

Temperature Coefficient:

≤ 300 ppm per degree C

Environmental:

Temperature Range:
Operating: 0°C to 40°C
Storage: -40°C to 85°C
Humidity:
10% to 90%, non-condensing.

Cooling:

Convection cooled

Dimensions:

1.49" H X 4.09" W X 6.73" D (38mm X 104mm X 171mm)

Weight:

2.2 pounds (1kg)

Interface/Power Connector:

9 pin male D connector

HV Output Connector:

HV positive: 29.5" (750mm) flying lead, coaxial HV cable
HV negative: 29.5" (750mm) flying lead, coaxial HV cable

Regulatory Approvals:

Compliant to EEC EMC Directive. Compliant to EEC
Low Voltage Directive. RoHS compliant.

MCP INTERFACE/POWER CONNECTOR

JB1	SIGNAL	SIGNAL PARAMETERS
1	Signal Ground	Signal Ground
2	Voltage Programming Input	0-10Vdc = 0-100% of Rated Output
3	+24V Input	+24V Input
4	+24V Input	+24V Input
5	Voltage Monitor	0-5Vdc=0-100% of Rated Output
6	Power Ground	Power Ground
7	Power Ground	Power Ground
8	Power Ground	Power Ground
9	Power Ground	Power Ground

DIMENSIONS: in.[mm]

FRONT VIEW



BACK VIEW

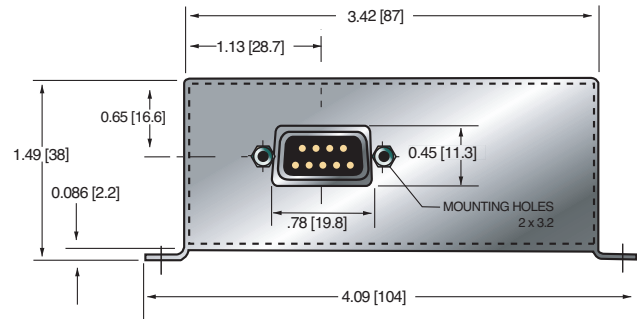

TOP VIEW

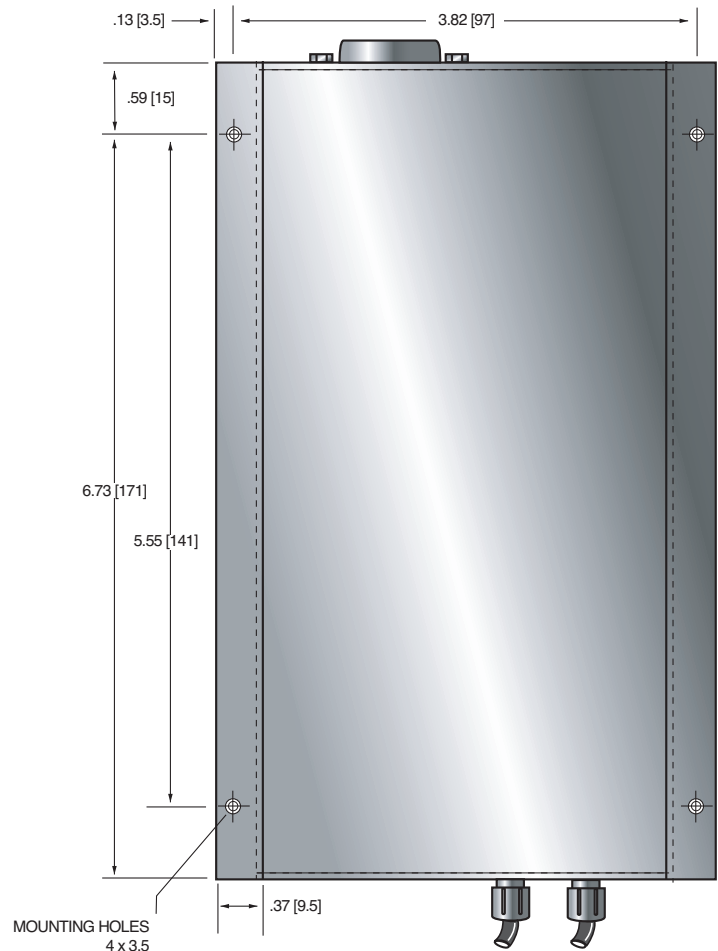



- **Hot Switchable Polarity Reversible Via a Logic Signal**
- **Well Regulated, Low Ripple**
- **Polarity Reversal Within 300mS**
- **Voltage and Current Monitor Outputs**
- **Remote HV Inhibit**
- **Small PCB Mount Module**
- **Arc and Short Circuit Protected**

Spellman's MX2.5 is a well-regulated high performance DC-DC converter featuring a "hot switchable" polarity reversal capability. The MX's low ripple specification makes it ideal for Mass Spectrometry applications; especially security detection systems, Dynodes, sample ionization as well as capillary electrophoresis and electrostatic printing applications.

The MX2.5 is rated at 2.5kV @ 60uA and is packaged in a shielded metal enclosure. This unit features a logic signal input to control output polarity reversal. A HV inhibit feature, along with voltage and current monitors are provided. Easily customized to meet OEM requirements, the MX2.5 can be provided with improved ripple performance and higher voltage and current capabilities.

TYPICAL APPLICATIONS

Mass Spectrometry
Capillary Electrophoresis
Electrostatic Printing

SPECIFICATIONS

Input Voltage:

+24Vdc, ± 0.5 volt

Input Current:

<200mA continuous

Output Voltage:

± 100 Vdc to ± 2.5 kV

Output Current:

0 to 60uA max.

Polarity:

Remotely reversible via logic signal, 300mS to settle to $\pm 1\%$, 1 Hz maximum switch rate

Voltage Regulation:

Load: 0.05% of maximum output voltage for a no load to full load change

Line: 0.05% of maximum output voltage for a 1 volt input line change

Voltage Programming:

0 to 10 volt corresponds to 0 to 100% of rated output voltage

Voltage/Current Monitor:

0 to 10 volt corresponds to 0 to 100% of rated output voltage/current

Programming and Monitor Accuracy:

$\pm 1\%$ Voltage Programming/Monitor
 $\pm 2\%$ Current Monitor

Ripple:

$\leq 0.02\%$ Volts p-p

Stability:

0.02% per hour after 1 hour warmup

Temperature Coefficient:

≤ 50 ppm per degree C

Environmental:

Temperature Range:
Operating: 0°C to 40°C
Storage: -40°C to 85°C

Humidity:
10% to 90%, non-condensing

Cooling:

Convection cooled

Dimensions:

1.18" H X 2.36" W X 4.72" D (30mm X 60mm X 120mm)

Weight:

Approximately 8.82 oz. (250g)

Interface/Power Connector:

PCB mount pins

HV Output Connector:

PCB mount pins

Regulatory Approvals:

Compliant to EEC EMC Directive. Compliant to EEC Low Voltage Directive. RoHS Compliant.

MX2.5 INPUT/OUTPUT CONNECTIONS

PIN	SIGNAL	SIGNAL PARAMETERS
1	+24V	Power Input
2	0v	Signal and Power Ground
3	V _{prog}	0-10V Programming Voltage
4	Polarity Change	Polarity Change Input
5	Shutdown	Output Inhibit, Disables HV Output Down to <60V Within 300ms
6	V _{mon}	0-10V Output Voltage Monitor
7	Output	HT Output
8	I _{mon}	0-10V Output Current Monitor

How to Order:

Standard: PART NO.:MX2.5PN24

DIMENSIONS: mm

SIDE VIEW

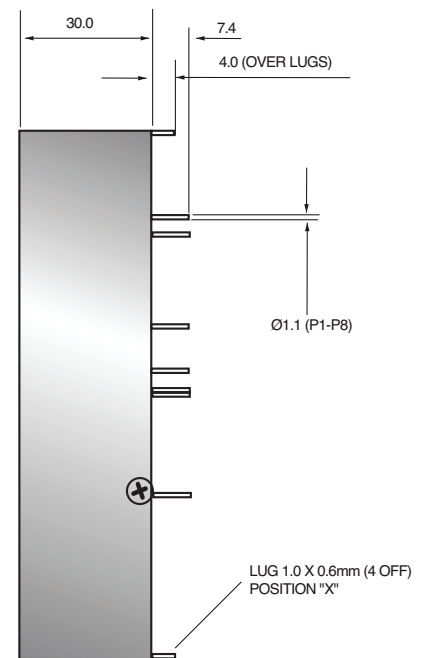

BOTTOM VIEW ON PINS

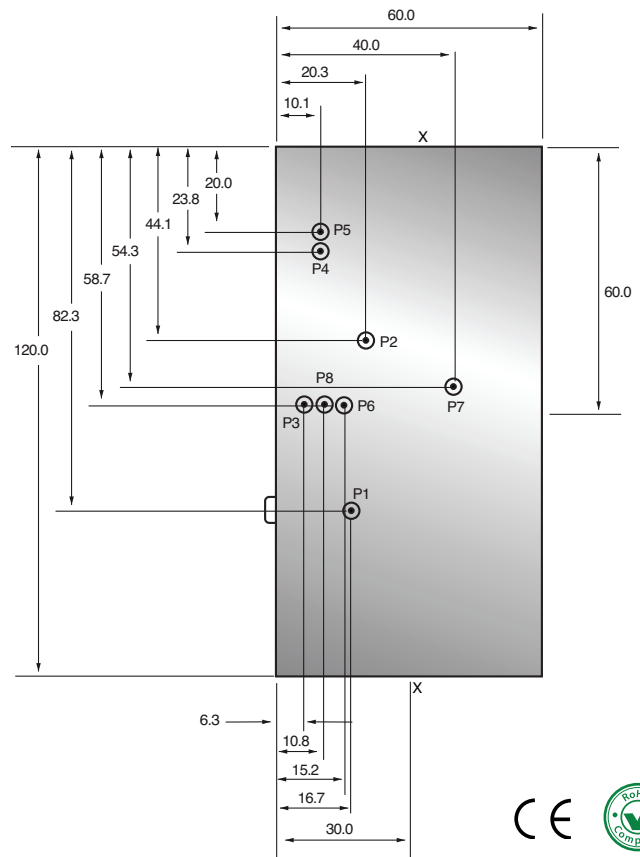



- ***±8kV 25ms Polarity Reversing Speed***
- ***Precision Analog Voltage and Current Controls***
- ***Precision Analog Voltage and Current Monitors***
- ***High Stability***
- ***Low Ripple and Noise***
- ***High Voltage Inhibit Control***
- ***RoHS Compliant***

Spellman's RoHS compliant MX8 Plus is a well-regulated high performance fast reversible supply featuring a 25ms "hot switchable" polarity reversing capability.

The MX8 Plus's low ripple specification is typical of the topologies that make Spellman High Voltage your ideal choice for mass spectrometry applications; especially security detection systems, dynodes, sample ionisation as well as capillary electrophoresis and electrostatic printing applications. The MX8 has been designed especially for EI and APCI applications.

The MX8 Plus can be easily tailored to an OEM's requirement, such as improved ripple performance, or different voltage and/or current capabilities.

TYPICAL APPLICATIONS

Mass Spectrometry
Capillary Electrophoresis
Electrostatic Printing

SPECIFICATIONS

Input Voltage:

+24Vdc, ±10%

Input Current:

<0.5A nominal continuous
<1.2A peak during reversing

Output Voltage:

0V to ±8kV (see note 1)

Output Current:

100µA

Output Polarity:

Bipolar

Voltage Regulation:

Line: <±0.1% for ±10% input voltage change
Load: <0.1% for 0 to full load

Current Regulation:

Line: ±0.1% for +1V input voltage change for any load condition
Load: ±0.1% for full load to short circuit

Ripple:

<0.1% p-p @ 100µA

Temperature Coefficient:

≤100ppm per degree C

Environmental:

Temperature Range:
Operating: 5°C to 45°C
Storage: -35°C to 85°C
Humidity:
10% to 85%, non-condensing

Stability:

0.05% per hour after 1 hour warm up

Polarity Reversal Time:

<25ms from command to 90% into 100pF load capacitance (see note 2)

Protection:

Arc and short circuit protected

Output Voltage Limit:

Output voltage must not exceed ±8kV ±250V under any input or output conditions

Dimensions:

1.48" H X 3.23" W X 9.45" D (37.6mm X 82mm X 240mm)

Weight:

Approximately 3.3 pounds (1.5kg)

Input Connector:

14 way Molex housing p/n 39-01-2140 or similar with female terminals. Cable length 508mm

Output Connector:

Alden F303D24, mating connector not provided

Regulatory Approvals:

Compliant to EEC EMC Directive. Compliant to EEC Low Voltage Directive. UL/CUL recognized file E227588. RoHS compliant.

Note 1: Linearity not guaranteed below 200V. Maximum offset ±20V when programmed to zero or disabled using remote enable.

Note 2: Unit incorporates circuitry to minimize the effects of low programmed current on reversing time. Polarity reversal time applies when current is programmed to 3µA or above.

MX8 PLUS 14 PIN SOCKET

PIN	SIGNAL
1	+24Vdc Input
2	Chassis and 24Vdc Ground
3	Enable/Inhibit Input
4	8kV Voltage Monitor output
5	Voltage Control Input
6	Current Monitor Output
7	Current Control Input
8	Polarity Control Input
9	Analog Ground
10	Current/Voltage Control Indicator
11	N/C
12	N/C
13	N/C
14	N/C

How to Order:

Standard: PART NO.:MXP8PN24

DIMENSIONS: in.[mm]

SIDE VIEW

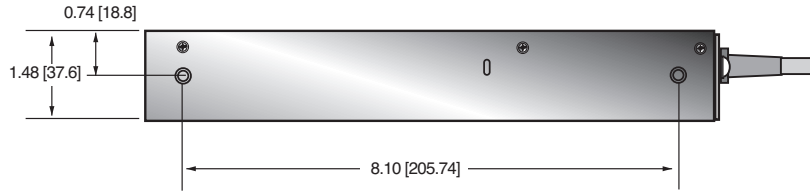

TOP VIEW

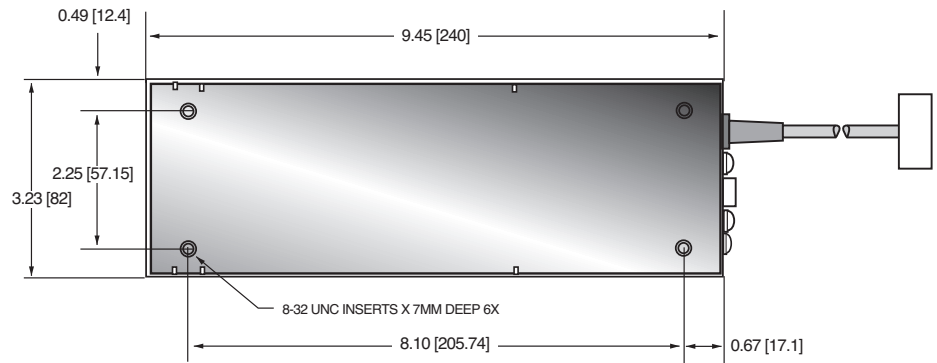

FRONT VIEW





- **Hot Switchable Polarity Reversible Via a Logic Signal**
- **Well Regulated, Low Ripple**
- **Polarity Reversal Within 250mS (Option to Improve to 100mS)**
- **Voltage and Current Monitor Outputs**
- **Remote HV Inhibit**
- **Flying High Voltage Output Cable**
- **Voltage or Current Control Options**

www.spellmanhv.com/manuals/MX10

Spellman's MX10 is a well-regulated high performance DC-DC converter featuring a "hot switchable" polarity reversal capability. The MX10's low ripple specification makes it ideal for Mass Spectrometry applications; especially security detection systems, Dynodes, sample ionization as well as capillary electrophoresis and electrostatic printing applications.

The MX10 is rated at 10kV @ 100uA and is packaged in a shielded metal enclosure. This unit features a logic signal input to control output polarity reversal. A HV inhibit feature, along with voltage and current monitors are provided. Easily customized to meet OEM requirements, the MX10 can be provided with current control, improved ripple performance and higher voltage and current capabilities.

TYPICAL APPLICATIONS

Mass Spectrometry
Capillary Electrophoresis
Electrostatic Printing

OPTIONS

VCC: Voltage and Current Control

SPECIFICATIONS

Input Voltage:

+24Vdc, ± 1 volt

Input Current:

<400mA continuous
<1.2A during reversing

Output Voltage:

± 200 Vdc to ± 10 kV

Output Current:

0 to 100uA max.

Polarity:

Remotely reversible via logic signal, 250mS to settle to $\pm 2\%$, 1 Hz maximum switch rate

Voltage Regulation:

Load: 0.1% of maximum output voltage
for a no load to full load change
Line: 0.1% of maximum output voltage for a
1 volt input line change

Current Regulation: (VCC Option)

Load: 0.1% of maximum rated current for a
0 to 100% voltage change
Line: 0.1% of maximum rated current for a
1 volt input line change

Voltage/Current Programming:

0 to 10 volt corresponds to 0 to 100% of rated
output voltage

Voltage/Current Monitor:

0 to 10 volt corresponds to 0 to 100% of rated
output voltage

Programming and Monitor Accuracy:

$\pm 2\%$

Ripple:

$\leq 0.005\%$ Volts p-p

Stability:

0.1% per hour after 1 hour warmup

Temperature Coefficient:

≤ 100 ppm per degree C

Environmental:

Temperature Range:
Operating: 0°C to 40°C
Storage: -40°C to 85°C
Humidity:
10% to 90%, non-condensing.

Cooling:

Convection cooled

Dimensions:

1.63" H X 6.61" W X 4.53" D (41.5mm X 168mm X 115mm)

Weight:

Approximately 3 pounds (1.4kg)

Interface/Power Connector:

9 pin male D connector

HV Output Connector:

39.4" (1m) Flying Lead of URM76 LSF cable

Regulatory Approvals:

Compliant to EEC EMC Directive. Compliant to EEC
Low Voltage Directive. UL/CUL recognized file E227588.
RoHS Compliant.

MX10 TERMINAL BLOCK 9 PIN

PIN	SIGNAL	SIGNAL PARAMETERS
1	Voltage Monitor	0-10V=0-100% of Rated Output
2	External Inhibit Input	Open or >10V = "OFF"; <4V = "ON"
3	Current Programming Input	0-10Vdc = 0-100% of Rated Output (on VCC option)
4	Signal Ground	Signal Ground
5	Current Monitor	0-10Vdc = 0-100% of Rated Output
6	Polarity Control Input	Open or >10V = "NEGATIVE"; <4V = "POSITIVE"
7	Voltage Programming Input	0-10Vdc = 0-100% of Rated Output
8	+24V Input	+24V Input
9	Power Ground	Power Ground

How to Order:

Standard: PART NO.:MX10PN24

VCC Option: PART NO.:MX10PN24/VCC

DIMENSIONS: in.[mm]

SIDE VIEW



TOP VIEW

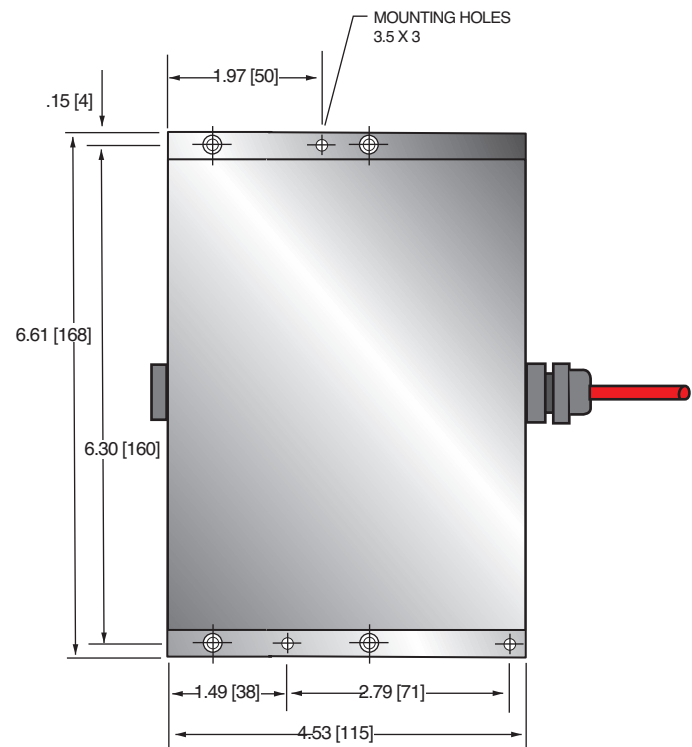



- **$\pm 10\text{kV}$ 25ms Polarity Reversing Speed**
- **Integrated Electron Multiplier Supply**
- **Precision Analog Voltage Control**
- **High Stability**
- **Low Ripple and Noise**
- **High Voltage Inhibit Control**
- **RoHS Compliant**

Spellman's RoHS compliant MX10 Plus is a well-regulated high performance fast reversible dynode supply featuring a 25ms "hot switchable" polarity reversing capability with an integrated -2.3kV electron multiplier supply.

The MX10 Plus's low ripple specification is typical of the topologies that make Spellman High Voltage your ideal choice for mass spectrometry applications; especially security detection systems, dynodes, sample ionisation as well as capillary electrophoresis and electrostatic printing applications. The MX10 Plus has been designed especially for dynode detector applications.

The MX10 Plus can be easily tailored to an OEM's requirement, such as improved ripple performance, or different voltage and/or current capabilities.

TYPICAL APPLICATIONS

Dynode Supply
Electron Multiplier Supply

SPECIFICATIONS

Input Voltage:

+15Vdc, $\pm .75\text{Vdc}$

Input Current:

$\leq 500\text{mA}$ nominal continuous
 $< 2\text{A}$ during reversing

Temperature Coefficient:

$\leq 100\text{ppm}$ per degree C

Environmental:

Temperature Range:
Operating: 5°C to 45°C
Storage: -35°C to 85°C

Humidity:
10% to 85%, non-condensing

Stability:

(constant operating conditions)
 $\leq 300\text{ppm}$ per hour after 1 hour warm up

Protection:

Arc and Short circuit protected

Regulatory Approvals:

Compliant to EEC EMC Directive. Compliant to EEC Low Voltage Directive. RoHS Compliant.

DYNODE SPECIFICATIONS

Output Voltage:

$\pm 10\text{kV}$

Output Current:

$10\mu\text{A}$

Output Polarity:

Remotely reversible via TTL logic signal

Switching Speed:

25ms to settle 90% into 50pF load

Voltage Regulation:

Line: $\leq 0.02\%$ for a 1.5V input voltage change

Ripple:

≤ 10 Volts p-p

ELECTRON MULTIPLIER SPECIFICATIONS

Output Voltage:

Fixed: 0 to -2.3kV

Output Polarity:

Negative

Output Current:

$\leq 230\mu\text{A}$

Voltage Regulation:

Line: $\leq 0.02\%$ for a 1.5V input voltage change

Load: $< 5\text{V}$ for for no load to 22M Ohms load change

Ripple:

$\leq 200\text{mV}$ p-p @ 2.3kV into 22M Ohm load

Output Rise Time:

10ms

Output Fall Time:

10ms

Dimensions:

2.00" H X 5.30" W X 8.00" D (50.8mm X 134.6mm X 203mm)

Weight:

Approximately 3.3 pounds (1.5kg)

Interface/Power Connector:

20 pin flat ribbon connector

Output Connector:

$\pm 10\text{kV}$: modified Alden #A200 connector

-2.3kV: MHV Kings bulkhead KV-79-15 or similar

MX10 PLUS TERMINAL BLOCK 20 PIN

PIN	SIGNAL
1	+15Vdc Input
2	+15Vdc Input
3	N/C
4	N/C
5	Ground
6	Ground
7	Output Voltage Control
8	Signal Reference Ground
9	10kV On
10	10kV On
11	Output Polarity Control
12	EM Protect
13	-2.3kV Output Monitor
14	EM On
15	Ground
16	Ground
17	±10kV Output Monitor
18	N/C
19	+15Vdc Input
20	+15Vdc Input

How to Order:

Standard: PART NO.:MXP10PN15

DIMENSIONS: in.[mm]

SIDE VIEW

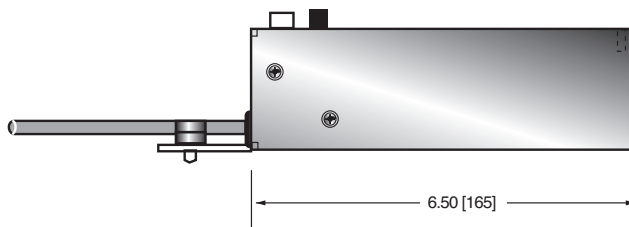

TOP VIEW

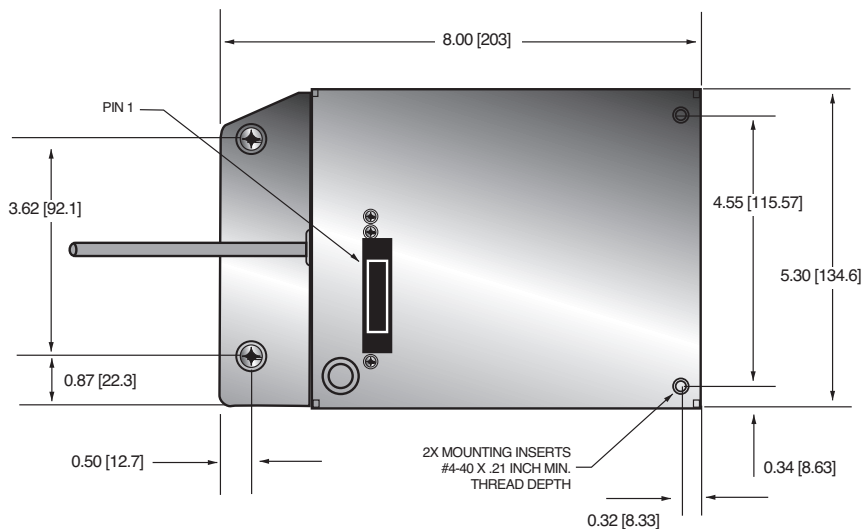

FRONT VIEW

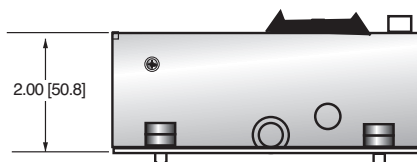



Spellman's MX20 is a well-regulated high performance DC-DC converter featuring a "hot switchable" polarity reversal capability. The MX20's low ripple specification makes it ideal for Mass Spectrometry applications; especially security detection systems, Dynodes, sample ionization as well as capillary electrophoresis and electrostatic printing applications.

The MX20 is rated at 20kV @ 100uA and is packaged in a shielded metal enclosure. This unit features a logic signal input to control output polarity reversal. A HV inhibit feature, along with voltage and current monitors are provided. Easily customized to meet OEM requirements, the MX20 can be provided with current control, improved ripple performance and higher voltage and current capabilities.

TYPICAL APPLICATIONS

Mass Spectrometry
Capillary Electrophoresis
Electrostatic Printing

OPTIONS

VCC: Voltage and Current Control

SPECIFICATIONS

Input Voltage:

+24Vdc, ± 1.2 volts

Input Current:

<500mA continuous
<1.2A during reversing

Output Voltage:

± 500 Vdc to ± 20 kV

Output Current:

0 to 100uA max.

Polarity:

Remotely reversible via logic signal, 500mS to settle to $\pm 2\%$, 1 Hz maximum switch rate

Voltage Regulation:

Load: 0.02% of maximum output voltage for a no load to full load change
Line: 0.01% of maximum output voltage for a 1 volt input line change

- **Hot Switchable Polarity Reversible Via a Logic Signal**
- **Well Regulated, Low Ripple**
- **Polarity Reversal Within 500mS**
- **Voltage and Current Monitor Outputs**
- **Remote HV Inhibit**
- **Flying High Voltage Output Cable**
- **Voltage or Current Control Options**

www.spellmanhv.com/manuals/MX20

Current Regulation: (VCC Option)

Load: 0.1% of maximum rated current for a 0 to 100% voltage change
Line: 0.01% of maximum rated current for a 1 volt input line change

Voltage/Current Programming:

0 to 10 volts corresponds to 0 to 100% of rated output voltage/current

Voltage/Current Monitor:

0 to 10 volts corresponds to 0 to 100% of rated output voltage/current

Programming and Monitor Accuracy:

$\pm 2\%$ Voltage Programming/Monitor
 $\pm 5\%$ Current Programming/Monitor

Ripple:

$\leq 0.0025\%$ Volts p-p

Stability:

0.1% per hour after 1 hour warmup

Temperature Coefficient:

≤ 100 ppm per degree C

Environmental:

Temperature Range:
Operating: 0°C to 40°C
Storage: -40°C to 85°C
Humidity:
10% to 90%, non-condensing

Cooling:

Convection cooled

Dimensions:

2.05" H X 6.61" W X 6.50" D (52mm X 168mm X 165mm)

Weight:

Approximately 5.51 pounds (2.5kg)

Interface/Power Connector:

9 pin male D connector

HV Output Connector:

39.4" (1m) Flying Lead of URM76 LSF cable

Regulatory Approvals:

Compliant to EEC EMC Directive. Compliant to EEC Low Voltage Directive. RoHS Compliant.

MX20 TERMINAL BLOCK 9 PIN

PIN	SIGNAL	SIGNAL PARAMETERS
1	Voltage Monitor	0-10V=0-100% of Rated Output
2	External Inhibit Input	Open or >10V = "OFF"; <4V = "ON"
3	Current Programming Input	0-10Vdc = 0-100% of Rated Output (on VCC option)
4	Signal Ground	Signal Ground
5	Current Monitor	0-10Vdc = 0-100% of Rated Output
6	Polarity Control Input	Open or >10V = "NEGATIVE"; <4V = "POSITIVE"
7	Voltage Programming Input	0-10Vdc = 0-100% of Rated Output
8	+24V Input	+24V Input
9	Power Ground	Power Ground

How to Order:

Standard: PART NO.:MX20PN24

VCC Option: PART NO.:MX20PN24/VCC

DIMENSIONS: in.[mm]

SIDE VIEW



TOP VIEW

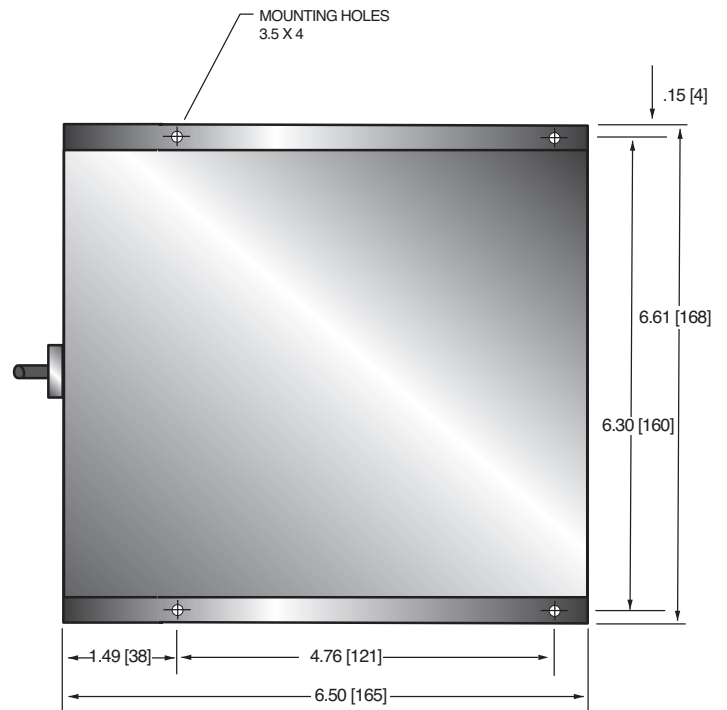



- **Hot Switchable Polarity Reversible within 2s settling to <3ppm**
- **Remote Polarity Reversal and HV Inhibit**
- **Voltage and Current Monitor Outputs**
- **Arc and Short Circuit Protected**
- **Well Regulated, Low Ripple, High Stability**
- **UL Recognized**
- **OEM Customization Available**

Spellman's MXR Series are well-regulated high performance DC-DC converters. The MXR's low ripple specification makes it ideal for Mass Spectrometry and electron microscopes. The MXR20 is rated at 20kV @ 300uA and MXR30 is rated at 30kV @ 300uA. Both are packaged in a shielded metal enclosure. These units feature a logic signal input to control output polarity reversal. A HV inhibit feature, along with voltage and current monitors are provided. Easily customized to meet OEM requirements, the MXR Series can be provided with current control, improved ripple performance and higher voltage and current capabilities.

TYPICAL APPLICATIONS

Mass Spectrometry
Electron Microscopes
Capillary Electrophoresis
Electrostatic Printing

OPTIONS

/DDC 2 RS-232

SPECIFICATIONS

Input Voltage:

24Vdc ($\pm 10\%$)

Input Current:

1.25A

Output Voltage:

$\pm 20V$ to $\pm 20kV$ (MXR20)

$\pm 30V$ to $\pm 30kV$ (MXR30)

Output Current:

300 μ A

Voltage Regulation:

Load: 50ppm of maximum output voltage for a no load to full load change

Line: <20ppm of maximum output voltage for a 5% input line change

Programming and Monitor Accuracy:

$\pm 2\%$ Voltage Programming/Monitor

Ripple:

10ppm

Stability:

0.1% per hour after 1 hour warmup

Temperature Coefficient:

10ppm/ $^{\circ}$ C

Reversing Time:

2s for +20kV to -20kV or +30kV to -30kV settling to <3ppm, faster versions are available

Environmental:

Temperature Range:

Operating: 0 $^{\circ}$ C to 50 $^{\circ}$ C

Storage: -40 $^{\circ}$ C to 85 $^{\circ}$ C

Humidity:

10% to 90%, non-condensing

Cooling:

Convection cooled

Dimensions:

2.05" H X 8.47" W X 9.13" D (52mm X 215mm X 230mm)

Weight:

Approximately 8.80 pounds (4.0kg)

Input Connectors:

Power: 2 way Molex Mini-fit Jr connector

Digital: 10 way 'IDC Ribbon cable' connector

Analogue: 12 way Molex KK5.08 series connector

Output Connectors:

Standard output either via co-ax cable (open ended) or GES HB30 receptacle, other output options available.

Regulatory Approvals:

Compliant to EEC EMC Directive. Compliant to EEC

Low Voltage Directive. RoHS Compliant.

MXR POWER VIA 2 WAY MOLEX

PIN	SIGNAL
1	+24Vdc Input
2	Ground return for +24Vdc

MXR DIGITAL INPUT— 10 WAY IDC RIBBON CONNECTOR

PIN	SIGNAL
1	Transmit data (output) with respect to pin 1
2	Serial signal ground return (if required)
3	Receive data (input) with respect to pin 2
4	N/C
5	N/C
6	N/C
7	Interlock opto-isolator input
8	Interlock opto-isolator signal return
9	Polarity change signal opto-isolator input
10	Polarity change signal opto-isolator signal return

MXR ANALOG INPUT— 12 WAY MOLEX KK5.08 CONNec-

PIN	SIGNAL
1	Current monitor output
2	+24Vdc Input
3	Voltage monitor output
4	N/C
5	N/C
6	N/C
7	Voltage program input
8	Polarity set input
9	Signal ground
10	+24Vdc return
11	N/C
12	Polarity status output

DIMENSIONS: in.[mm]

SIDE VIEW



TOP VIEW

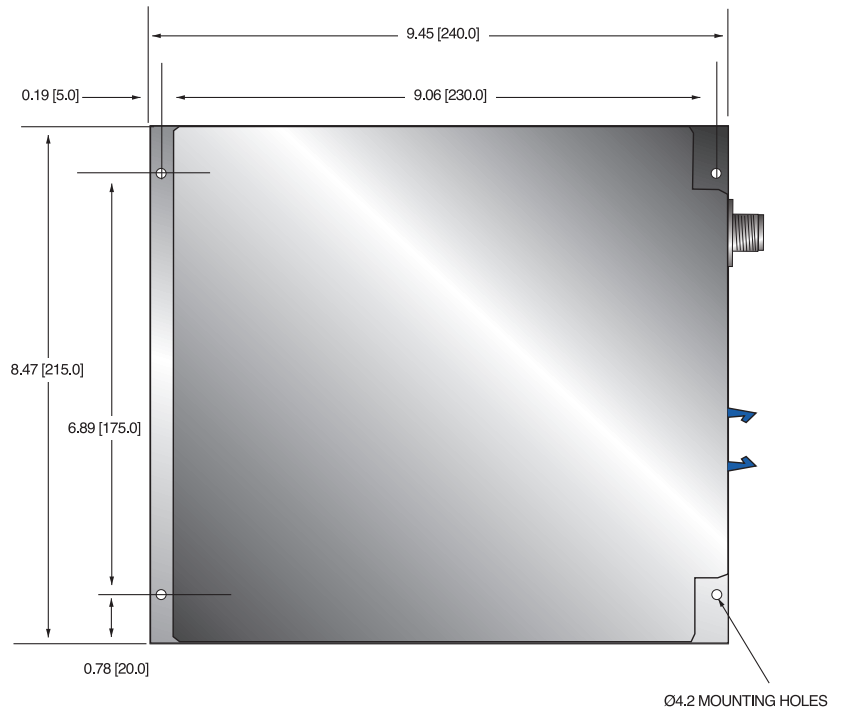

FRONT VIEW

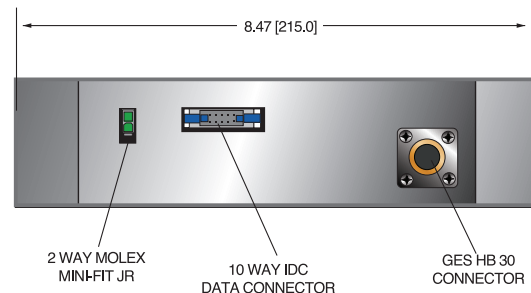

How to Order:

Standard: PART NO.: MXR20PN24
PART NO.: MXR30PN24





- **Remote Output Polarity Reversibility Via TTL Signal Control**
- **Ultra Low Ripple and Noise**
- **Small Footprint OEM Modular Packaging**
- **Encapsulated for Reliable, Long Term Corona Free Operation**
- **CE and RoHS Compliant**

The TOF3000 offers critical specifications like ultra low ripple and noise, excellent temperature coefficient; a stable, repeatable and accurate output, along with remote output polarity reversing capability. These superior specifications result in improved mass spectrometer resolution. Unique high voltage packaging and surface mount fabrication techniques, coupled with Spellman's proprietary encapsulation technology provide this unit in an attractive sized OEM package.

Featuring a 0-30kV @ 400 μ A output with remote polarity reversing capability and dimensions of 3"H x 5"W x 12 5/8"L, the TOF3000 is a small, cost-effective high voltage power supply with technology that sets the standard for the future of Mass Spectrometry applications.

TYPICAL APPLICATIONS

Mass Spectrometry

SPECIFICATIONS

Input Voltage:

+24 Vdc, +5%, -2%

Input Current:

2 amps maximum

Output Voltage:

0 to 30kV

Output Current:

0 to 400 microamperes

Polarity:

Positive or Negative with respect to ground, reversible via TTL signal

Voltage Regulation:

Line: 0.001% for input change of 1 volt
Load: 0.001% for 100 μ A to full load change

Current Regulation:

Line: 0.05% for +5% to -2% input change
Load: 0.1% for 0 to maximum output voltage

Ripple:

\leq 70mV peak to peak

Stability:

0.01% per hour, 0.02% per 8 hours after 1.0 hour warm up period

Temperature Coefficient:

25ppm per degree C

Environmental:

Temperature Range:

Operating: 0°C to 50°C

Storage: -20°C to 65°C

Humidity:

10% to 90% RH, non-condensing

Control Interface

Voltage Program Input:

0 to +10Vdc corresponds to 0 to \pm 30kV, $Z_{in} \geq 1$ megohm

Program Accuracy:

\pm 0.15% at 15KV, with overall accuracy of \pm 0.25% of maximum output

TTL Polarity Reversal:

High = positive polarity

Low = negative polarity

Voltage Monitor:

0 to 10Vdc corresponds to 0 to 30KV, $Z_{out} = 4.7$ Kohm

Current Monitor:

0 to 10Vdc corresponds to 0 to 400 μ A, $Z_{out} = 4.7$ Kohm

Cooling:

Convection cooled

Dimensions:

3"H X 5"W X 12.625"D (76.2mm x 127mm x 321.7mm)

Weight:

9.5 pounds (4.31kg)

Interface Connector:

15 pin male D connector

Output Connector:

Alden B102, which accepts Alden B200 cable plug

Regulatory Approvals:

Compliant to EEC EMC Directive. Compliant to EEC Low Voltage Directive. UL/CUL recognized, File 148969. RoHS Compliant

JB1 INTERFACE CONNECTOR

PIN	SIGNAL	SIGNAL PARAMETERS
1	Spare	N/C
2	Voltage Program	0 to 10V=0 to 100% Rated Output
3	Spare	N/C
4	Spare	N/C
5	Voltage Monitor	0 to 10V=0 to 100% Rated Output
6	TTL Polarity Control Signal	Hi=Positive Polarity, Low=Negative Polarity
7	Signal Ground	Signal Ground
8	Power Ground	Power Ground
9	Spare	N/C
10	Spare	N/C
11	Spare	N/C
12	TTL HV Enable	Hi=Inhibit, Low=Enable
13	Current Monitor	0 to 10V=0 to 100% Rated Output
14	Spare	N/C
15	+24Vdc	+24Vdc



DIMENSIONS: in.[mm]

FRONT VIEW

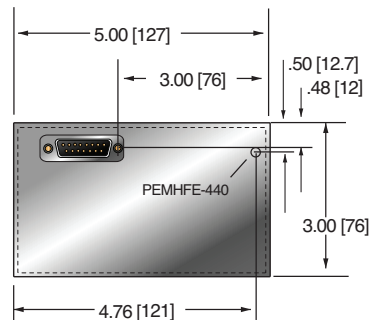

BACK VIEW

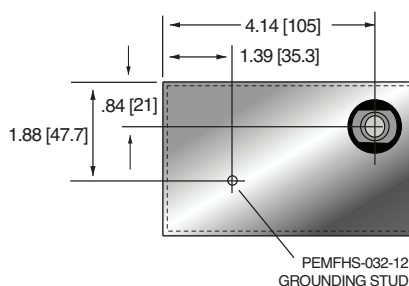

TOP VIEW

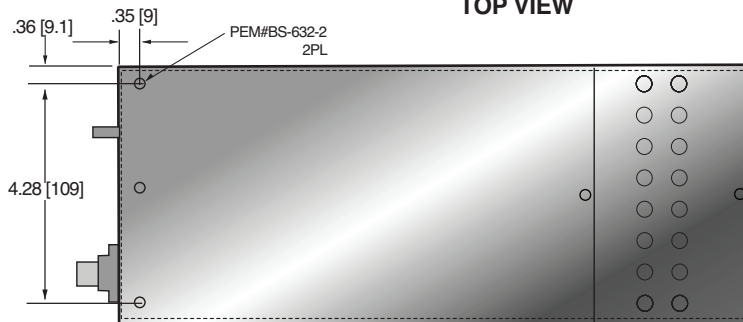

BOTTOM VIEW

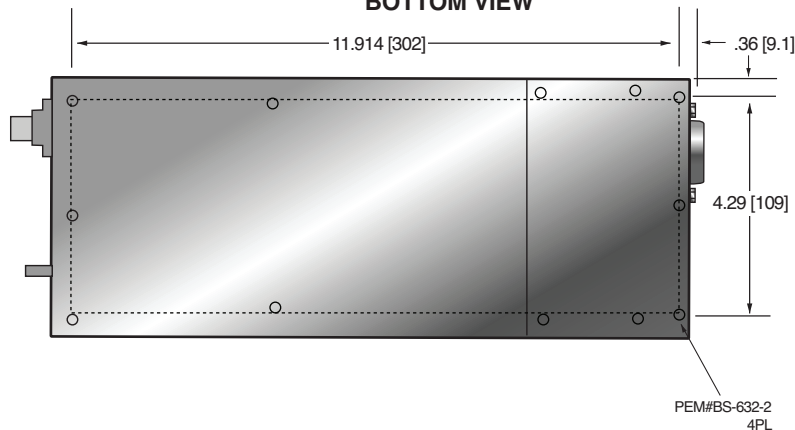



- **Integrated Accelerator and Ion Source Chassis**
- **High Performance Ground Reference Lens Chassis**
- **Very Low Ripple and Ultra Stable Outputs**
- **Robust Arc and Short Circuit Protection**
- **Design to Minimise Micro-discharge Events**
- **Optically Isolated Digital Interface**
- **CE Marked & Designed to Meet SEMI S2**

Spellman's FIB Series is an integrated multiple output high voltage power supply specifically designed for focused ion beam applications. It incorporates a high stability accelerator voltage with the floating outputs to drive traditional Ga Ion and Plasma Sources. An additional Lens Chassis is available, providing the high performance fixed or reversible polarity high voltage lenses required to focus the Ion Beam. Both the Main Chassis and Lens Chassis are 19" rack mountable. Focused Ion Beam is typically used in the semiconductor industry, materials science and increasingly in the biological field for imaging, etching and deposition of materials.

The Main Chassis provides an Acceleration voltage up to 35kV, with floating Filament, Extractor and Suppressor outputs, all designed to the exacting performance requirements for FIB applications. The Lens Chassis offers Lens voltages up to 30kV, with fixed or Reversible polarity. All outputs are offered with ultra-low output ripple, excellent regulation, stability, temperature coefficient, drift and accuracy specifications. Isolation and control of the respective floating sources is provided via Spellman's proprietary high voltage isolation techniques. Customer control of this integrated FIB power supply system is accomplished via a fiber optic interface. All high voltage safety interlocks are of a failsafe hardware based design. The FIB is CE marked and is designed to be compliant with applicable IEC, UL and SEMI standards. Consult factory for final configuration requirements.

TYPICAL APPLICATIONS

Focused Ion Beam (FIB)
Ion Gun Controller

SPECIFICATIONS

Input Voltage:

+24Vdc, ±5% @ 5.5 amps maximum.
Inrush is <6 amps for 1 second.

Safety Fuse:

A 5 x 20mm ceramic fuse changeable from the outside and marked with the fuse value.

Power Switch:

A shielded rocker switch allows the unit to be switched ON and OFF from the rear panel.

Environmental:

Operating Temperature:

+10°C to +45°C ambient for normal operation.
The unit will operate from 0°C but will require an extended warm up period.

Storage Temperature:

-20°C to +60°C

Humidity:

0 to 80% RH, non-condensing

Altitude:

2000 meters ASL at full power. For altitudes above 2000 meters the maximum ambient operating temperature is linearly derated by 1.1°C per 300 meter interval.

Mechanical:

Main chassis (rack mountable): See dimension drawings

Lens chassis (rack mountable): See dimension drawings

Weight:

Main chassis: <66.12 lbs. (<30kg)

Lens chassis: <22.04 lbs. (<10kg)

Software:

All communications to the power supply is through a fiber optic link operating at 19.2 kbaud, or Ethernet. A basic self-test capability is provided. This self-test will verify internal consistency of the HVPS, including internal supply voltage levels, reference voltages, firmware integrity, etc. However, the HVPS will not change any output voltages during this test.

Regulatory Approvals:

IEC61010:2010 Safety requirements for electrical equipment for measurement, control and laboratory use. UL61010-1:2012 Safety Requirements for Electrical Equipment for Measurement, Control, and Laboratory Use - Part 1: General Requirements and CAN/CSA-C22.2 No.61010-1-12:2015. The unit is CE marked against EN61010:2010 and EN61326-2-1:2013 and is RoHS compliant.

ACCELERATOR SUPPLY
Output Voltage:

0 V to +35 kV, referenced to ground.
100V absolute accuracy

Output Current:

30 μ A maximum

Current Limit:

30 μ A maximum

Load Regulation:

$\pm 0.01\%$ of maximum for 0-100% rated current change

Line Regulation:

100mV over input power range

Ripple:

200mV p-p, from 0.1Hz to 1MHz at 30kV and 30 μ A

Temperature Coefficient:

25ppm/ $^{\circ}$ C

Stability:

1.5V/10 hours after 2 hour warm-up

Programming:

16 bit resolution, 0V to +35kV

Monitoring:

14 bit resolution, 0V to +35kV, $\pm 1\%$ accuracy (± 50 V offset)
14 bit resolution, 0 μ A to 30 μ A, $\pm 1\%$ accuracy ($\pm 0.3\mu$ A offset)

Response:

<1.0 second

FILAMENT SUPPLY
Output Voltage:

0 to 5Vdc, referenced to Accelerator, current controlled

Output Current:

0 to 5 amp, 5mA absolute accuracy

Load Regulation:

$\pm 0.1\%$ of maximum for 0 to maximum rated voltage change

Line Regulation:

5mA over input power range

Ripple:

10mA p-p, from 0.1Hz to 1MHz

Temperature Coefficient:

200 ppm/ $^{\circ}$ C

Stability:

5 mA/10 minutes after 2 hour warm-up

Programming:

16 bit resolution, 0A to 5A

Monitoring:

16 bit resolution, 0V to 5V, $\pm 4\%$ accuracy (± 0.1 V offset)
16 bit resolution, 0A to 5A, $\pm 4\%$ accuracy (± 50 mA offset)

Response:

< 0.10 sec, >5A/s measured between 10% to 90% or
90% to 10%

SUPPRESSOR SUPPLY
Output Voltage

-2 kV to +2kV, referenced to Accelerator,
 ± 20 V absolute accuracy

Output Current:

30 μ A

Current Limit:

30 μ A

Load Regulation:

$\pm 0.01\%$ of maximum for 0 to maximum rated voltage change

Line Regulation:

100mV over input power range

Ripple:

150mV p-p, from 0.1Hz to 1MHz

Temperature Coefficient:

25 ppm/ $^{\circ}$ C

Stability:

0.5 V/10 hours after 2 hour warm-up

Programming:

16 bit resolution, -2kV to +2kV

Monitoring:

14 bit resolution, -2kV to +2kV, $\pm 1\%$ accuracy (± 8 V offset)

Response:

<0.25 sec

EXTRACTOR SUPPLY
Output Voltage:

0 to -15kV, referenced to Accelerator,
100V absolute accuracy

Output Current:

400 μ A

Current Limit:

programmable, 8 bit resolution, 0 μ A to 400 μ A, (default
value on supply enable is 400 μ A)

Load Regulation:

$\pm 0.01\%$ of maximum for 0 to maximum rated voltage change

Line Regulation:

100 mV over input power range

Ripple:

100mV p-p, from 0.1Hz to 1MHz at 30 μ A and below

Temperature Coefficient:

25 ppm/ $^{\circ}$ C

Stability:

0.5 V/10 hours after 2 hour warm-up

Programming:

16 bit resolution, 0V to -15kV

Monitoring:

16 bit resolution, 0V to -15kV, $\pm 1\%$ accuracy (± 15 V offset)
16 bit resolution, 0 μ A to 400 μ A:
10 μ A to 400 μ A, $\pm 3\%$ accuracy ($\pm 5\mu$ A offset)
0 μ A to 10 μ A, > 5kV, $\pm 0.05\mu$ A accuracy ($\pm 0.05\mu$ A offset)

Response:

<1 sec
>1.33kV/s measured between 10% to 90% and 90% to 10%

Trips:

Hard trip at 400 μ A in <0.25 sec programmable trip delay
(for when current at I limit). 0 sec to 255 sec, 8 bit resolution
(5 sec minimum, 20 second default)

LENS 1 SUPPLY
Output Voltage:

0kV to +30 kV referenced to ground
100V absolute accuracy

Output Current:

30 μ A

Current Limit:

30 μ A

Load Regulation:

$\pm 0.01\%$ of maximum for 0 to maximum rated current change

Line Regulation:

100mV over input power range

Ripple:

100mV p-p, from 0.1Hz to 1MHz

Temperature Coefficient:

25 ppm/ $^{\circ}$ C

Stability:

1.0 V / 10 hours after 2 hour warm-up

Programming:

16 bit resolution, 0 to +30kV

Monitoring:

16 bit resolution, 0kV to +30kV, $\pm 1\%$ accuracy ($\pm 30V$ offset)
16 bit resolution, 0 μ A to +30 μ A, $\pm 3\%$ accuracy ($\pm 1\mu$ A offset)

Response:

<0.1 s

<4 sec to reach <2V away from steady state for
20kV to 18kV change.

<4 sec to reach <2V away from steady state for
18kV to 20kV change.

>6.0kV/s measured between 10% to 90% or 90% to 10%

Wobble Range:

2V to 2.5kV peak to peak, sinusoidal. If wobbling occurs near zero, the wobble waveform will be clipped so as to prevent crossing zero.

Wobble Period:

1 second to 4 seconds

LENS 2 SUPPLY
Output Voltage:

-30kV to +30kV referenced to ground
100V absolute accuracy

Polarity:

Bipolar

Output Current:

30 μ A

Current Limit:

30 μ A

Load Regulation:

$\pm 0.005\%$ of maximum for 0 to maximum rated current change

Line Regulation:

100mV over input power range

Ripple

200mV pk-pk, from 0.1Hz to 1MHz

Temperature Coefficient:

25 ppm/ $^{\circ}$ C

Stability:

1.0V / 10 hours after 2 hour warm-up

Programming:

16 bit resolution, -30kV to +30kV

Monitoring:

14 bit resolution, -30kV to +30kV, $\pm 1\%$ accuracy ($\pm 15V$ offset)
14 bit resolution, -30 μ A to +30 μ A, $\pm 3\%$ accuracy ($\pm 1\mu$ A offset)

Response:

<0.1 s

<4 sec to reach <2V away from steady state for
20kV to 18kV change.

<4 sec to reach <2V away from steady state for
18kV to 20kV change.

Wobble Range:

2V to 2.5kV peak to peak, sinusoidal. If wobbling occurs near zero, the wobble waveform will be clipped so as to prevent crossing zero.

Wobble Period:

1 second to 4 seconds

Additional Bipolar:

The above specifications do not apply in the range -500V to +500V. Operation at 0V output is not a requirement. The module must enable at 0V output. Programming and monitoring is offset binary

Indicators:
Power On:

A green LED illuminates when 24Vdc is applied to the unit

Interlock:

A yellow LED illuminates when the interlock(s) are made

Interlocks:

If the interlock is not present communication over the optical bus will remain operational.

Output voltages will be <1000V in <30 seconds when the interlock opens. The interlock will deactivate the power supply via relay contacts and will not reactivate until the supply is enabled through the computer control, even though the interlock may close.

Panel removal: all outputs disabled

Upper column: All outputs except lens 2 disabled

Lens 2: Disable only the lens 2 output

The individual modules of the HVPS can be enabled and disabled through computer control, provided the appropriate hardware interlocks are enabled.

Lens Supply Options:

LENS 1	LENS 2
+30kV	+25kV/-15kV
-30kV	+25kV/-15kV
+/-30kV	+/-30kV
+/-20kV	+/-30kV

INPUT POWER— AMP/TYCO 2-PIN MATE-N-LOCK

PIN	SIGNAL	I/O	PARAMETERS
1	+24Vdc	I	Power input
2	0V	I	Power ground

MAIN HV CONNECTOR

The main high voltage output is fitted with a custom 4 pole receptacle. See page 5 of 6 for detail.

INTERLOCK— 9 PIN FEMALE D CONNECTOR

PIN	SIGNAL	PARAMETERS
1	Not used	Not connected internally
2	Not used	Not connected internally
3	Not used	Not connected internally
4	Not used	Not connected internally
5	+ Upper Column Interlock	Current limited interlock supply
6	- Upper Column Interlock	Opto isolated interlock input
7	+ Lens 2 Interlock	Current limited interlock supply
8	- Lens 2 Interlock	Opto isolated interlock input
9	Shield/Ground	Ground

Switch closure turns ON or enables the supplies

RJ45 ETHERNET CONNECTOR —

PIN	SIGNAL	PARAMETERS
1	TD+	TD+
2	TCT (3V3)	TCT (3V3)
3	TD-	TD-
4	RD+	RD+
5	RCT (3V3)	RCT (3V3)
6	RD-	RD-
7	N/C	No Connection
8	0V (reference)	0V (reference)
9	0V (reference)	0V (reference)
10	0V (reference)	0V (reference)
11	N/C	No Connection
12	N/C	No Connection

The RJ45 socket is fitted for future use, it is configured for 10/100 Mb/s systems using the IEEE 802.3 serial management interface and can only be used for this purpose and is fitted with a blanking plug

LENS 1 CONNECTOR—Lemo ERA3Y430CTL

LENS 2 CONNECTOR—Lemo ERA3Y430CTL

FIBER CONNECTOR

The fiber optics communications connector is a dual channel Avago HFBR- 2524z/1524z connector.

INTERCONNECTIONS BETWEEN CHASSIS



COMMUNICATIONS

The main chassis is provided with a 9 pin D connector which connects via a “one to one” cable to the same connector on the lens chassis. This allows the main chassis to control and monitor the lens outputs. An additional connector is provided on the lens chassis to allow a second lens chassis to be connected to the base unit via the first lens chassis.

INTERCONNECTION POWER— AMP/TYCO 3-PIN MATE-N-LOCK

PIN	SIGNAL	I/O	PARAMETERS
1	0V	I	DC24V Common
2	N/C	I	No Connection
3	+ 24V	I	DC24V Input

Power is transferred between the two chassis via 3 pin “Mate-n-Lok” style connectors. This is interlocked via the main chassis.

An additional power connector is also provided on the lens chassis to allow 24V to be provided to a second lens chassis.

Input and Output cables are not provided with unit. Interconnect cables are provided with the unit. Consult factory for available options.

Main Chassis

DIMENSIONS: in.[mm]

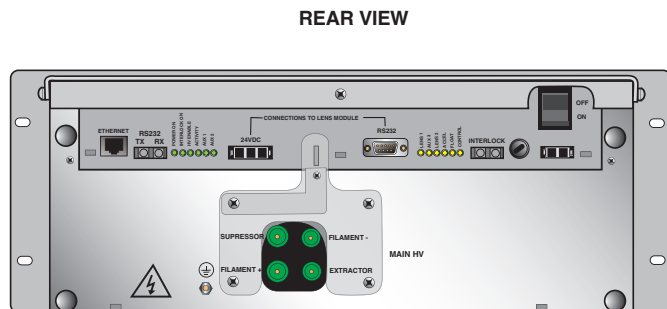
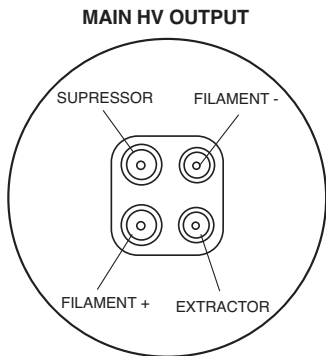
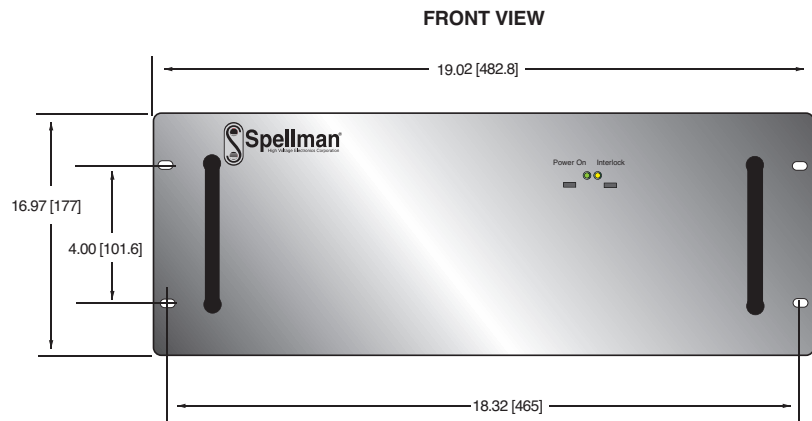
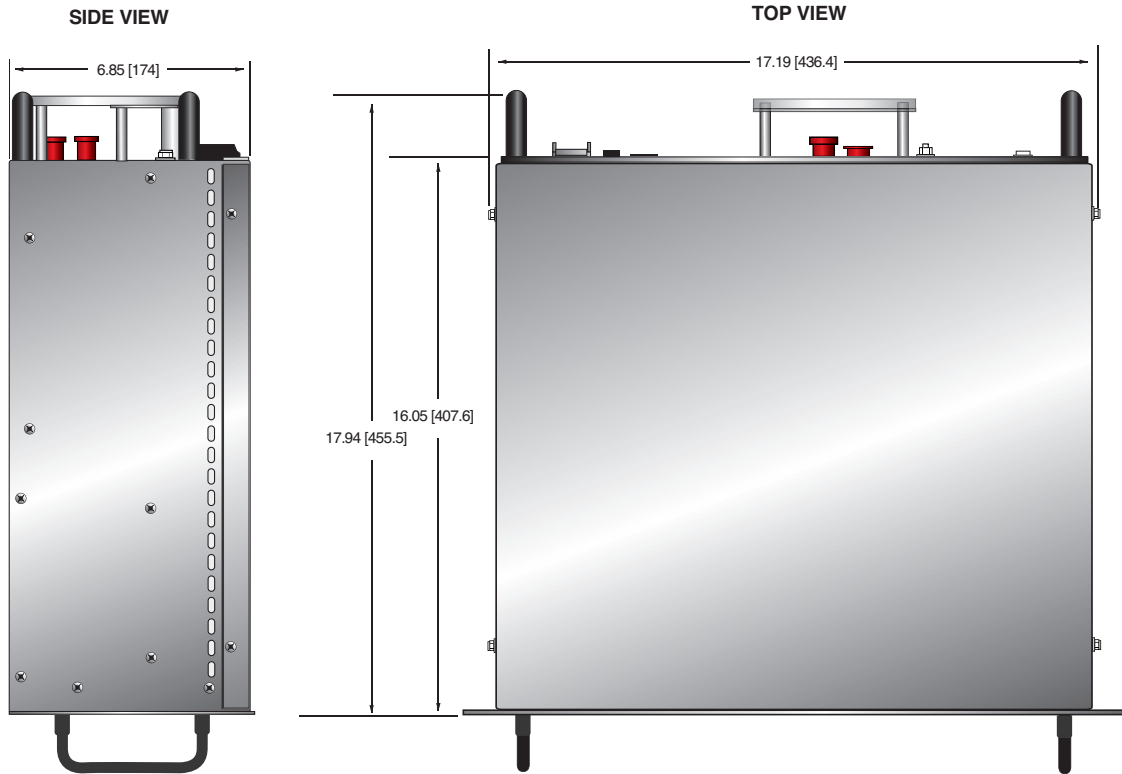

Lens Chassis

DIMENSIONS: in.[mm]

SIDE VIEW



TOP VIEW

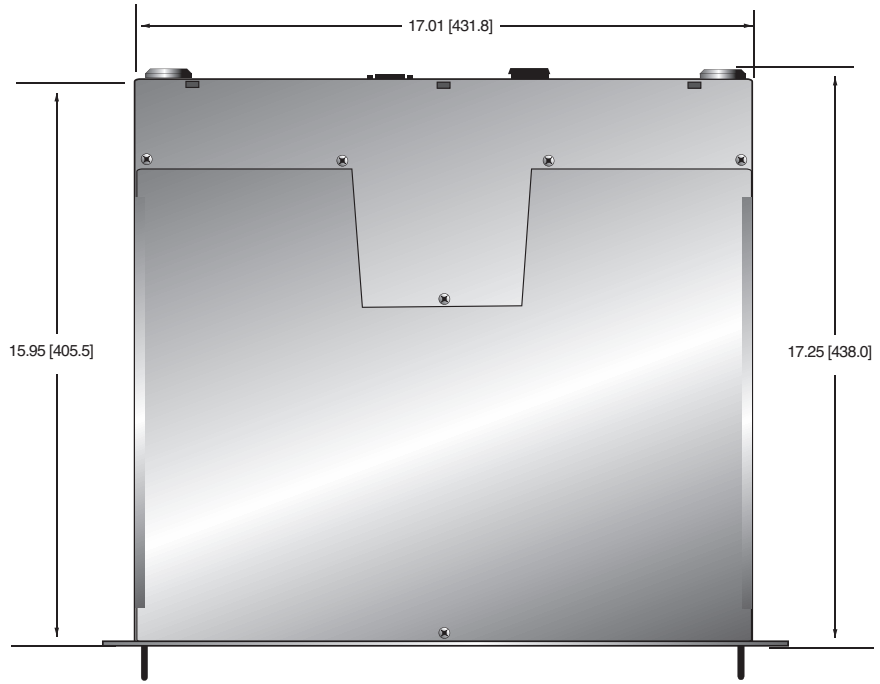

FRONT VIEW

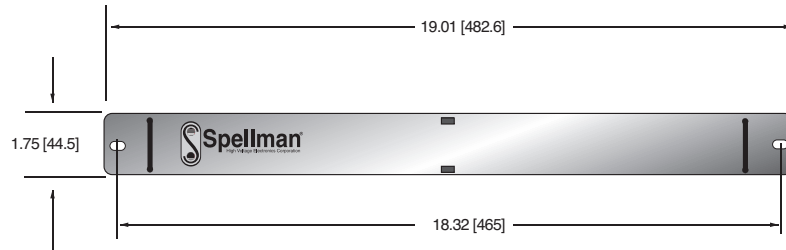

REAR VIEW





- **Integrated Single Chassis Solution**
- **High Stability, Very Low Ripple**
- **Encapsulated HV Section**
- **Corona Free Operation**
- **Optically Isolated Digital Interface**
- **CE Marked & Designed to Meet SEMI S2**

Spellman's FIBX power supply is an integrated multiple output high voltage power supply specifically designed for focused ion beam. Typical applications include transmission and scanning electron microscopy; semiconductor analysis, milling and repair; disc drive head trimming, ion beam etching and focused ion-beam lithography.

A modular design approach allows individual sub-assemblies to be easily configured in a common rack mounted 6U chassis assembly. Interface, logic and control circuitry utilizes surface mount technology, minimizing cost and size. Spellman's leadership in patented power conversion technology and proprietary high voltage packaging and encapsulation techniques provides reliable and fault free operation in all FIB operating environments.

Individual supplies (Accelerator, Filament, Extractor, Suppressor or Lens) are designed to exacting application specific standards, with ultra low output ripple, excellent regulation, stability, temperature coefficient, drift and accuracy specifications. Isolation and control of the respective floating sources are provided via Spellman's proprietary high voltage isolation techniques.

Customer control of this integrated FIB power supply system is accomplished via a fiber optic isolated RS-232 interface. All high voltage safety interlocks are of a fail-safe hardware based design. The FIBX is CE marked and is designed to be compliant with applicable IEC, UL and SEMI standards.

TYPICAL APPLICATIONS

- Transmission scanning electron microscopy
- Scanning electron microscopy
- Semiconductor analysis, milling and repair
- Ion beam etching
- Focused ion-beam lithography

SPECIFICATIONS

Input Voltage:

105 to 240Vac, 47 to 63 Hz

ACCELERATOR SUPPLY Referenced to Ground

- Output Voltage:** 0 to +45 kV
- Output Current:** 30 μ A
- Ripple:** 200 mV p-p, from 0.1 Hz to 1 MHz
- Line Regulation:** 100 mV for +/-10% line change
- Load Regulation:** \pm 0.01% of maximum voltage for full load change
- Stability:** 1.5 volts/10 hours after 2 hour warm-up

- Temperature Coefficient:** 25 ppm/ $^{\circ}$ C

FILAMENT SUPPLY Referenced to Accelerator

- Output Voltage:** 0 to 5 Vdc
- Output Current:** 0 to 5 A
- Ripple:** 10 mA p-p from 0.1 Hz to 1 MHz
- Line Regulation:** 5 mA for +/-10% line change
- Load Regulation:** \pm 0.1% of maximum voltage for full load change
- Stability:** 5 mA/10 minutes after 2 hour warm-up

- Temperature Coefficient:** 200 ppm / $^{\circ}$ C

SUPPRESSOR SUPPLY Referenced to Accelerator

Output Voltage: -2 kV to +2 kV
Output Current: 30 μ A
Ripple: 150 mV p-p from 0.1 Hz to 1 MHz
Line Regulation: 100 mV for +/-10% line change
Load Regulation: \pm 0.01% of maximum voltage for full load change

Stability: 500mV/10 hours after 2 hour warm-up

Temperature Coefficient: 25 ppm/ $^{\circ}$ C

EXTRACTOR SUPPLY Referenced to Accelerator

Output Voltage: 0 to -15 kV
Output Current: 400 μ A
Ripple: 100 mV p-p, from 0.1 Hz to 1 MHz at 30 μ A and below

Line Regulation: 100 mV for +/-10% line change
Load Regulation: \pm 0.01% of maximum voltage for full load change

Stability: 500mV/10 hours after 2 hour warm-up

Temperature Coefficient: 25 ppm/ $^{\circ}$ C

LENS 1 SUPPLY Referenced to Ground

Output Voltage: 0 to -40 kV
Output Current: 30 μ A
Ripple: 150 mV p-p from 0.1 Hz to 1 MHz
Line Regulation: 100 mV for +/-10% line change
Load Regulation: \pm 0.01% of maximum voltage for full load change

Stability: 500 mV/10 hours after 2 hour warm-up

Temperature Coefficient: 25 ppm/ $^{\circ}$ C

LENS 2 SUPPLY Referenced to Ground

Output Voltage: 0 to +25 kV
Output Current: 30 μ A
Ripple: 150 mV p-p from 0.1 Hz to 1 MHz
Line Regulation: 100 mV for +/-10% line change
Load Regulation: \pm 0.005% of maximum voltage for full load change

Stability: 1.0 volts/10 hours after 2 hour warm-up

Temperature Coefficient: 25 ppm/ $^{\circ}$ C

Remote Interface:

A fiber optic isolated RS232 interface is provide for remote digital control and monitoring of all power supplies and their functions.

Environmental:

Operating temperature: 10 $^{\circ}$ C to 40 $^{\circ}$ C
 Storage temperature: -30 $^{\circ}$ C to 70 $^{\circ}$ C
 Humidity: 10% to 90%, non-condensing

Connectors:

Accelerator, Filament and Suppressor: 75kV, 3 conductor Federal Standard Xray connector

Extractor: LGH 2I
 Lens 1: LGH 3I
 Lens 2: LGH 2I

Input Voltage:

IEC320 EMI filtered input connector

Dimensions:

Industry standard 6U rack mounted chassis
 10.5" High X 19" Wide X 21" Deep
 26.7 cm X 48.3 cm X 53.34 cm

Weight:

Approximately 73 lbs (33 kg)

Regulatory Approvals:

Compliant to EEC EMC Directive. Compliant to EEC Low Voltage Directive. Designed to meet SEMI S2. UL/CUL recognized file E227588 (FIBX3434, FIBX3548, FIB35/655, MFIBX3193)





- **Electron Beam High Voltage Power Supply**
- **100kV Output Capability**
- **Low/High 10 μ A/100 μ A Output Current Selection**
- **Less than 75mV of Ripple**
- **Excellent Regulation and Stability Performance**
- **Oil Free/Solid Encapsulated Design**

The Bertan VS100 high voltage power supply was specifically designed for precision electron beam applications like semiconductor nano-lithography, micro-optics and development mask work. Its ultra low ripple and excellent stability specifications make it ideal for use in these demanding applications. A switch selectable low and high output current range is featured.

The solid encapsulated high voltage section eliminates any user maintenance issues, while isolating the components from environmental variables. The unit is fully overload, arc and short circuit protected. Remote control programming and monitoring capability is provided. A second high voltage monitor, separate from the control electronics is provided. This allows accurate passive measurement of the high voltage output.

TYPICAL APPLICATIONS

Micro-Optics
Semiconductor lithography
Development mask work

SPECIFICATIONS

Input Voltage:

220Vac, $\pm 10\%$, single phase 50/60 Hertz

Output Voltage:

0 to 100kV, negative polarity. Externally switch selectable to 105kV, ± 500 volts

Output Current:

0-10 μ A, low range
0-100 μ A, high range
Switch selectable

Line Regulation:

$\pm 0.001\%$ of rated voltage over specified input voltage range

Load Regulation:

$\leq 20V$ for a current change of 25 μ A to 60 μ A and 60 μ A to 25 μ A

Ripple:

$\leq 75mV$ peak to peak

Partial High Voltage Discharge:

less than 200mV

Stability:

0.001% per 8 hours after a 6 hour warm up, for a temperature of 20°C $\pm 0.2^\circ$ C

Temperature Coefficient:

50ppm per degree C over a 10°C to 40°C range

Environmental:

Operating Temperature: 0 to 40 degrees C
Storage Temperature: -40 to 85 degrees C
Humidity: 10 to 90% RH, non condensing

Cooling:

Forced Air-control chassis;
Convection Cooled- high voltage chassis

Front Panel:

Power ON/OFF switch
HV ON/OFF switch
HV ON/OFF indicator
Analog output voltage meter

Dimensions:

Control Chassis: 5.25" H X 19" W X 15.3" D
(13.3cm X 48.3cm X 38.4cm)
HV Chassis: 10.25" H X 19" W X 27" D
(26.7cm X 48.3cm X 55.9 cm)

Weight:

Control Chassis: 20 pounds (9kg)
HV Chassis: 116 pounds (50kg)

Interface Connector:

19 pin Burndy GOB1619SNE
(mating connector provided)

AC Input Connector:

3 pin IEC320 input socket

Output HV Connector:

Claymount 2050-073

Output HV Cable:

Detachable at rear panel, cable not provided.

REMOTE INTERFACE CONNECTOR

PIN	SIGNAL	SIGNAL PARAMETERS
A	-5V Reference	-5.0 volts @ 10mA output
B	Voltage Programming	0 to -5v = 0 to 100% rated output, Z _{in} = 100KΩ
C	Spare	N/C
D	Spare	N/C
E	Monitor Common	Ground
F	HV Status	TTL High = HV OFF, TTL Low = HV ON
G	+5V	5 volts @ 250mA output
H	Interlock	Ground or TTL low to enable interlock
J	Program Common	Ground
K	Spare	N/C
L	Spare	N/C
M	Spare	N/C
N	Spare	N/C
P	Voltage Monitor	0 to -5V = 0 to 100% rated output, Z _{out} = 10KΩ
R	Current Monitor	0 to -5V = 0 to 100% rated output, Z _{out} = 10KΩ
S	Spare	N/C
T	Spare	N/C
U	Spare	N/C
V	Spare	N/C

DIMENSIONS: in.[mm]

HV CHASSIS

FRONT VIEW

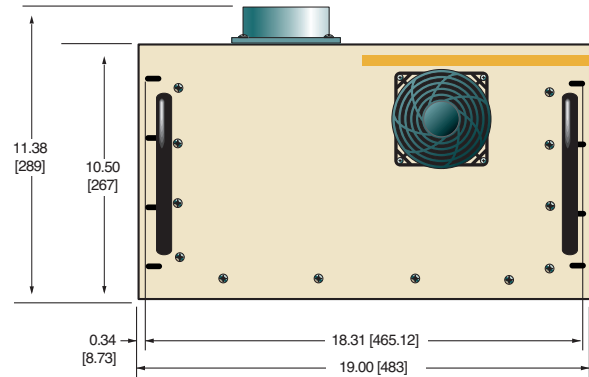

TOP VIEW

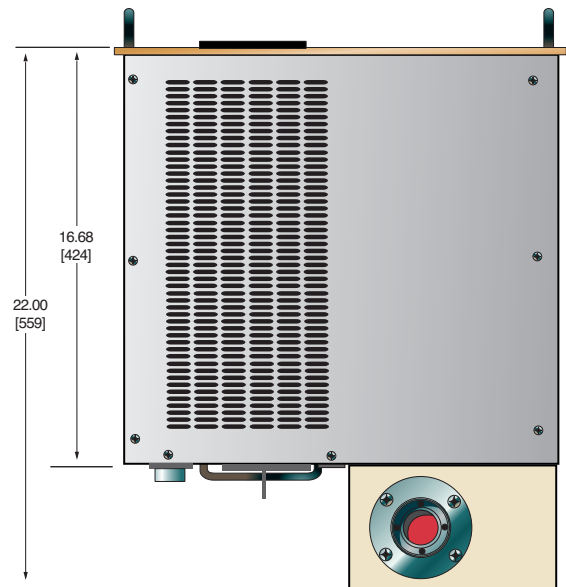

CONTROL CHASSIS

FRONT VIEW

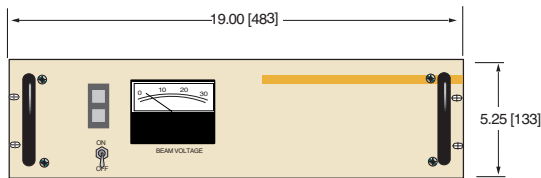

TOP VIEW

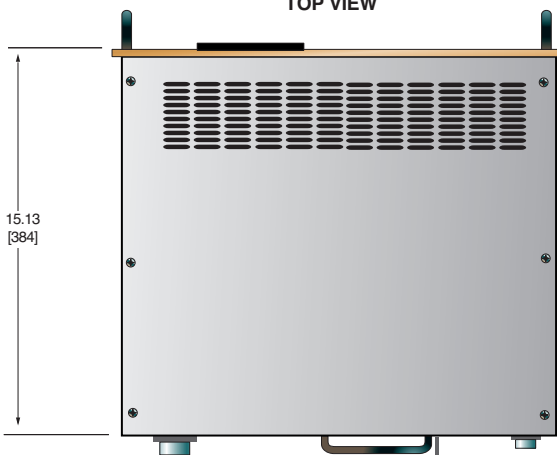

BACK VIEW

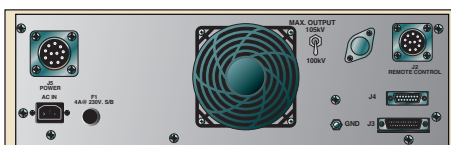

BACK VIEW

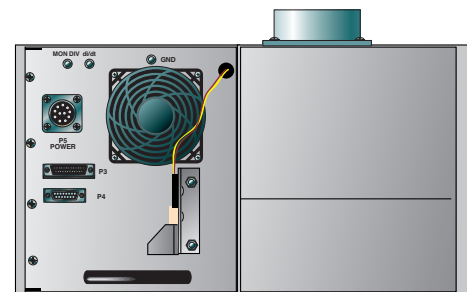



- **Triode Supply for Electron Beam Columns**
- **High Precision, Low Noise, Ultra Stable**
- **Over Current/Voltage Protection**
- **Arc and Short Circuit Protection**
- **OEM Customization Available**
- **UL, CE and RoHS Compliant**

The EBM powers E-Beam Columns in Scanning Electron Microscopes providing acceleration, bias and filament sources in a single compact package. Spellman's proprietary HV packaging and encapsulation technology gives dramatic improvements in size, cost and performance compared to other SEM power supply offerings. The EBM provides a highly regulated, low noise, ultra stable accelerator supply programmable from 0 to -30kV at 170uA. The EBM has floating bias and filament supplies referenced to the accelerator. Programming signals utilize differential analog inputs to minimize external noise and offset voltages effects. A ground referenced accelerator current monitor is provided. The EBM is arc and short circuit immune, along with over voltage and over current protection.

TYPICAL APPLICATIONS

Scanning Electron Microscope

SPECIFICATIONS

Input Voltage:

+24Vdc, ±5%

High Voltage Outputs:

ACCELERATOR:

Voltage:

0V to -30kV full load with respect to ground

Current:

170µA maximum, continuous from -300V to -3kV

Accuracy:

±2% or ±15V (whichever is greater)

Load Regulation:

<±100ppm

Line Regulation:

<±100ppm for 22.8V to 26.4V line change

Ripple:

<15ppm p-p at -30kV, 170µA, maximum bias and filament output

Temperature Coefficient:

<100ppm/°C

Stability:

8ppm/3 minutes at 150µA load current after 1 hour warm up

BIAS:

(Referenced to Accelerator)

Voltage:

0 to +3.5kV (max allowable output limited to 2kV)

Current:

150µA maximum

Accuracy:

±5% of full scale

Line Regulation:

<±0.1% for 10% line change

Ripple:

<150mVp-p at 30kV, 150µA, max. bias and filament output

Temperature Coefficient:

<1000ppm/°C

Stability:

6V/10 minutes

FILAMENT:

(Referenced to Accelerator)

Power:

0 to 15W

Load Resistance:

1 ±5%

Accuracy:

±3% of FS or 0.1V, which ever is greater

Load Regulation:

<2% for 10% change in load resistance

Line Regulation:

<1% for 10% line change

Ripple:

<0.1% p-p max

Temperature Coefficient:

<300ppm/°C

Stability:

100ppm/10 minutes

INTERFACE:

Input:

Analog control for beam energy, filament and bias

Output:

Mini75 receptacle (Claymount CA11 or similar)

Temperature:

Operating: 0°C to +45°C
Storage: -20°C to +75°C

Humidity:

0 to 85% RH, non-condensing

Dimensions:

4.13"H x 9.85"W x 7.48"D (105mm x 250mm x 190mm) excluding any mounting brackets

Weight:

<22 lbs. (10kg)

Regulatory Approvals:

Compliant to EEC EMC Directive. Compliant to EEC Low Voltage Directive. UL/CUL recognized, File E227588. (EBM30N6/582, /615, /636, /833, DPL72130/24). RoHS compliant.

DIMENSIONS: in.[mm]

FRONT VIEW

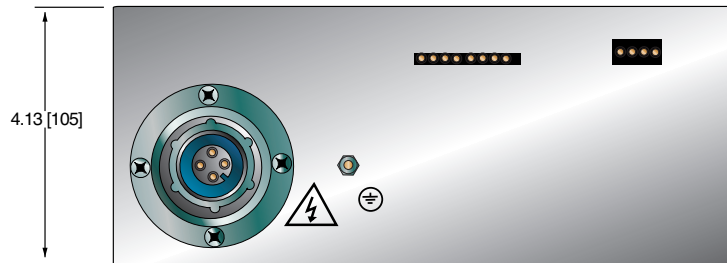

TOP VIEW

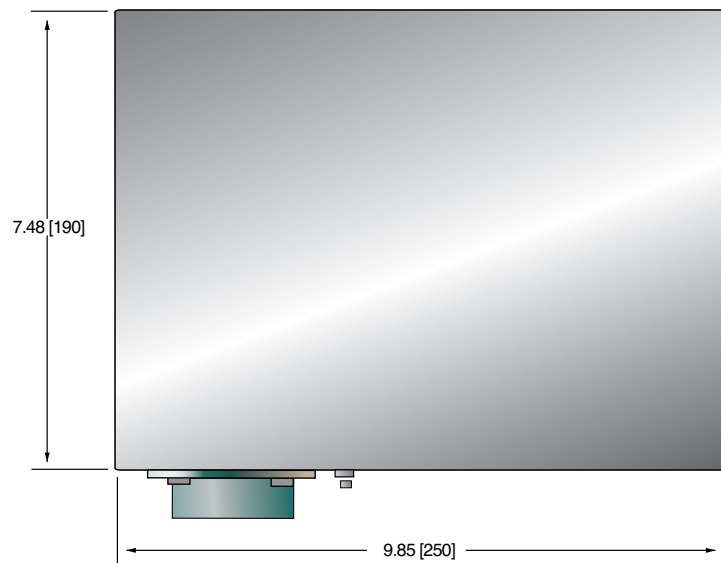

SIDE VIEW

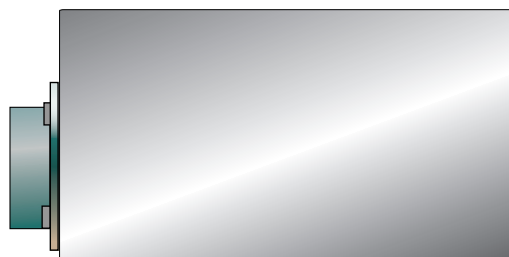



- **Integrated Accelerator and Electron Source Supplies**
- **Very Low Ripple and Ultra Stable Outputs**
- **Robust Arc and Short Circuit Protection**
- **Designed to Minimize Micro-discharge Events**
- **Optically Isolated Digital Interface**
- **CE Marked & Designed to Meet SEMI S2**

Spellman's EBM-FEG Series is an integrated multiple output high voltage power supply specifically designed to drive Scanning Electron Microscope (SEM) Columns. Spellman's extensive knowledge in this application has enabled us to develop a range of technology platforms that can be customized to meet the demanding requirements of SEM.

The main Acceleration Voltage is a high stability 30kV supply, with integrated floating Filament, Extractor and Suppressor outputs required to drive Field Emission, Cold Cathode and Schottky Electron Sources in a compact solution with extenders to mount in a 19" rack. All outputs are offered with ultra-low output ripple, excellent regulation, stability, temperature coefficient, drift and accuracy specifications. Isolation and control of the respective floating sources is provided via Spellman's proprietary high voltage isolation techniques.

Customer control of this integrated EBM-FEG power supply system is accomplished via a fiber optic interface. All high voltage safety interlocks are of a failsafe hardware based design and the EBM-FEG is CE marked and is designed to be compliant with applicable IEC, UL and SEMI standards. Spellman's EBM-FEG offers exceptional performance with low ripple, micro-discharge, and ppm level stability for unprecedented image quality and resolution.

TYPICAL APPLICATIONS

- Scanning Electron Microscopes (SEM)
- Electron Beam Controller

SPECIFICATIONS

Input Voltage:

+24Vdc, $\pm 5\%$ @ 4 amps maximum.
Inrush is <6 amps for 1 second.

Safety Fuse:

A 5 x 20mm ceramic fuse changeable from the outside and marked with the fuse value.

Leakage Current:

<200 μ A to case

Power Switch:

A shielded rocker switch allows the unit to be switched ON and OFF from the front panel.

Environmental:

Operating Temperature:

+10°C to +45°C ambient for normal operation.
The unit will operate from 0°C but will require an extended warm up period.

Storage Temperature:

-20°C to +60°C

Humidity:

0 to 80% RH, non-condensing

Altitude:

2000 meters ASL at full power. For altitudes above 2000 meters the maximum ambient operating temperature is linearly derated by 1.1°C per 300 meter interval.

Mechanical:

The unit is provided with a pair of removable mounting flanges; these allow the unit to mount in a 19" rack system. The unit can be operated in any orientation. An M5 x 23mm protective ground stud is mounted in the vicinity of the HV connector

Weight:

<48.5 lbs. (<22kg)

Regulatory Approvals:

IEC61010:2010 Safety requirements for electrical equipment for measurement, control and laboratory use. UL61010-1:2012 Safety Requirements for Electrical Equipment for Measurement, Control, and Laboratory Use - Part 1: General Requirements and CAN/CSA-C22.2 No.61010-1-12:2015. The unit is CE marked against EN61010:2010 and EN61326-2-1:2013 and RoHS compliant.

Beam Energy Supply

Output Voltage:

20V to 30kV, negative polarity. A conditioning voltage of 32.5kV with no load current is settable. The output will not exceed 35kV under any condition. The output can be set to OFF which disables the Beam Energy converter, in this case the output will be <60 volts.

Output Current:

200 μ A maximum, 20kV to 30kV

Output Current Trip Level:

250 μ A $\pm 10\%$ The output is disabled and latched off with a delay of approximately 1 second. The program voltage is set to zero.

Accuracy (Voltage Program):

<1% or $\pm 10V$ (whichever is greater) over control range

Voltage Control:

16 bit, resolution 0.5V, full scale = 32,768 volts

Linearity:

-20 to -30kV $< \pm 25V$

Load Regulation:

<±100mV for a 30µA to 200µA load change

Line Regulation:

<±10ppm from 22.8V to 26.4V line change

Ripple:

<50mVp-p @ 0uA to 200uA, 0.1Hz to 20MHz

Temperature Coefficient:

<10ppm/°C from +10°C to +45°C,

<5ppm/°C from +20°C to +30°C

Stability:

<200mV/15 minute period after 1 hour warm up under constant operating conditions.

Voltage Monitor:

16 bit, resolution 0.5V. Accuracy with respect to actual output voltage is ±2% or ±10V.

Current Monitor:

12 bit, resolution 100nA, accuracy is ±2% or ±1µA.

Wobble Amplitude:

0 to 100% modulation in steps of 1%, where 100% is defined

as ±5% of the Beam Energy output with a minimum value of ±50V. The peak to peak value is twice the amplitude.

Wobble Period:

666 to 2000 milliseconds. Adjustable in 1 millisecond steps. A sinusoidal output with 16 points per period. The wobble always starts and stops at a zero crossing.

Stored Energy:

<850mJ

Filament Supply**Connection:**

The center of the filament is connected to the Beam Energy output. The output can be set to off which disables the filament converter.

Voltage:

Nominally 1.8V, maximum 3V

Maximum Current:

3A, control range 0.5A to 3A

Load Resistance:

Nominal at 0.6Ω

Accuracy:

± 5mA between 2 and 3 Amperes

Current Control:

12 bit, resolution 1mA. Full scale = 4.096 Amperes

Linearity:

± 10mA between 0.5A and 3A

Load Regulation:

<5mA for 0.4Ω to 1.0Ω change at 3A. (Including output lead)

Line Regulation:

<1mA for 5% change in supply voltage.

Ripple:

<1mA p-p, 20Hz to 10 kHz and <30mV p-p at approximately 100kHz both across 0.6Ω @ 3.0A

Temperature Coefficient:

<50ppm/°C

Stability:

<0.5mA/60 minutes. After one hour warm up under constant operating conditions.

Voltage Monitor:

12 bit, resolution 2.5V, full scale = 10.24V. Accuracy with respect to actual output voltage: ±5% or ±25mV

Current Monitor:

12 bit, resolution +/-1mA, full scale = 4.096 Amperes. Accuracy with respect to actual output current ±10mA.

Trip OC:

Open circuit detection, $V_{out} > 5.2 \pm 0.1$ Volts. All outputs will be disabled and programs set to zero.

Trip Current:

Over current detected if the output current exceeds 3.15A for ten seconds. All outputs will be disabled and programs set to zero.

Extractor Supply**Voltage:**

0V to 10kV (positive with respect to Beam Energy). Control range +100V to +10kV. The output can be set to OFF which disables the extractor converter.

Current:

700µA over control range.

Current Trip Level:

Programmable 0 to 735µA resolution 0.25µA. Accuracy ±2% or 2µA. All outputs shall be disabled and programs set to zero

Accuracy (Voltage Program):

<1% or ±20V (whichever is greater) over control range

Voltage Control:

12 bit, resolution 2.5V, full scale = 10.24kV

Linearity:

±20V over the control range

Load Regulation:

<±1V (10µA – 700µA output current change)
<100mV @ 40µA 0.1Hz to 20MHz

Line Regulation:

<±5ppm for a +/-5% line change

Ripple:

<100mVp-p at 10kV, 700µA, 0.1Hz – 20MHz

Temperature Coefficient:

<25ppm/°C

Stability:

<0.3V/15 minutes; after one hour warm up under constant operating conditions

Ramp Rate:

10V/s to 1000V/s

Voltage Monitor:

12 bit, resolution 2.5V, full scale = 10.24kV. Accuracy with respect to actual output voltage: ±1% or ±20V

Current Monitor:

12 bit, resolution 0.25µA, full scale = 1.024mA. Accuracy with respect to actual output current: ±2% or ±2µA

Protection:

Continuous/intermittent arcs to the Beam Energy supply and ground.

Stored Energy:

<150mJ

Suppressor Supply

Voltage:

0V to 1000V (negative with respect to Beam Energy). Control range 100V to 1000V. The output can be set to OFF which disables the extractor converter.

Current:

<100µA over control range.

Current Trip Level:

100µA ±10% with a nominal five second delay. All outputs will be disabled and programs set to zero.

Accuracy (Voltage Program):

<2% or ±6V (whichever is greater) over control range

Voltage Control:

12 bit, resolution 0.25V, full scale = 1024V

Linearity:

±5V over the control range

Load Regulation:

<120mV for a 10µA to 100µA load current change.

Line Regulation:

<±5ppm for a +/-5% line change

Ripple:

<20mV p-p over control range, 0.1Hz to 20 MHz.

Temperature Coefficient:

<50ppm/°C

Stability:

<0.3V/15 minutes; after one hour warm up under constant operating conditions

Voltage Monitor:

12 bit, resolution 0.25V, full scale = 1.024kV. Accuracy with respect to actual output voltage: ±2% or ±250mV

Current Monitor:

12 bit, resolution 0.25µA, full scale = 1.024mA. Accuracy with respect to actual output current: ±10%

Protection:

Continuous/intermittent arcs to the Beam Energy or extractor

Stored Energy:

<2.5mJ

Vacuum Interlock:

The vacuum interlock is an optical interlock which is made when light is present on the fiber. When no light is present the interlock is broken and the unit shuts down all of the outputs.

Indicators:

Power On (front panel):

A green LED will be illuminated to indicate that +24V power is present. This LED will be illuminated over the range 22.8 to 25.2 volts and will flash with a 1 second period when out of range.

Vacuum Interlock (front panel):

A yellow LED will be illuminated to indicate that all the vacuum interlock is closed. The vacuum interlock LED must be illuminated for the unit to be able to generate high voltage.

Protection:

All outputs are protected from arcs in the load and continuous short circuit. Dielectric strength test voltage capability of outputs to be 36kV however no output is capable of exceeding this voltage.

All low voltage inputs are protected against over voltages of ±30 Volts. The power input is protected against over voltage and reversed connection.

Over Temperature:

Any semiconductor device exceeding an over temperature condition for greater than ten seconds will initiate a shut down and send an error message.

Shutdown Requirements:

Beam Energy output can be shut down independently. Filament, Suppressor and Extractor outputs (Emission) should be shut down together.

INPUT POWER CONNECTOR

PIN	SIGNAL	PARAMETER
1	+24Vdc	+24Vdc @ 4A
2	Power Ground	Power Ground

VACUUM INTERLOCK CONNECTOR

The vacuum interlock connector is a dual channel Avago HFBR- 2524z/1524z connector.

OPTICAL COMMUNICATIONS CONNECTOR

The fiber optics communications connector is a dual channel Avago HFBR- 2524z/1524z connector.

HIGH VOLTAGE OUTPUT CONNECTOR

The main high voltage output will be fitted with a custom 4 pole receptacle:

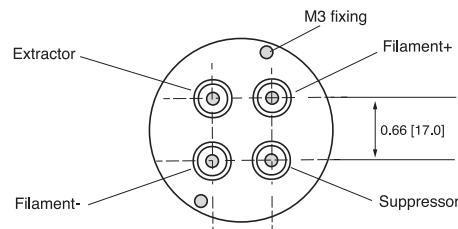

Mating cable can either be supplied by Spellman or Spellman will provide manufacturing drawings such that the customer can manufacture the cable assembly.

How To Order:
PART NUMBER: EBM30N6/FEG

DIMENSIONS: in.[mm]

REAR VIEW

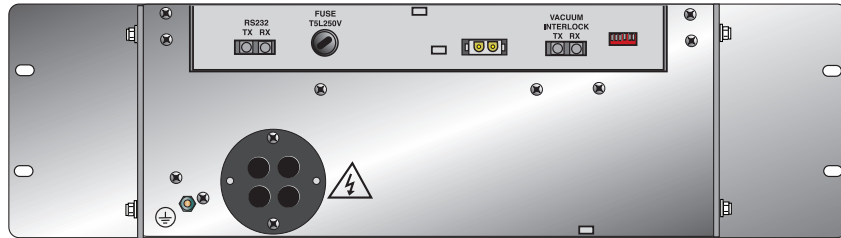

TOP VIEW

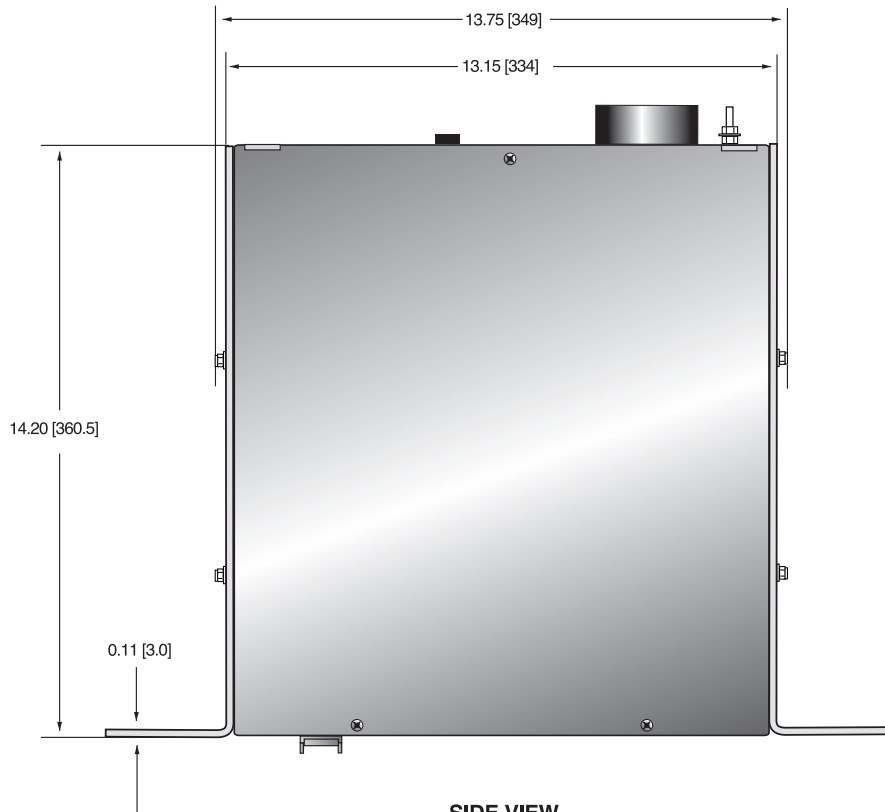

SIDE VIEW

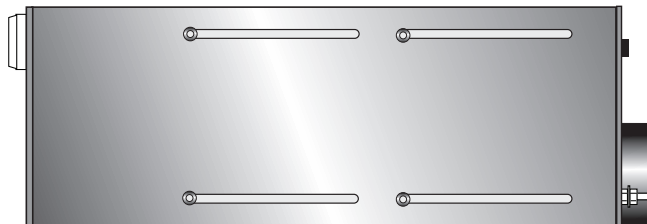



- **Full Array of Dry Contact Closures Available for Remote Station Alarm Monitoring**
- **Fully-Programmable Electronic Test Load Capable of Dissipating 5kW**
- **Electroding Functions Provided**
- **Single Cabinet. Rear Door Provided for Safety Interlocking**

Spellman High Voltage Electronics, the leading independent supplier of Power Feed Equipment to the Telecom industry, has developed a new generation of Low Voltage Power Feed Equipment, (LVPFE). This proposed new LVPFE is targeted at the emerging requirements for shorter submarine cable installations, while addressing underlying markets issues such as lower cost, smaller foot print, and easier operation.

KEY FEATURES

- Redundancy is provided for the converters (1+1)
- Simplified sliding drawers for PFE open, grounding, test modes
- Redundancy is provided for the LCU. In case of failure of LCU, the PFE will continue to operate normally
- LCU contains pull-out 17" LCD screen, keyboard, trackball and CPU
- Simplified keylock scheme ensures safety of operating personnel
- Highly visible Vacuum Fluorescent Display (VFD) on each Converter displays voltage, current and modes of operation
- Unique protective "trap door" barrier allows a converter or test load to be replaced safely while the PFE is still powering the cable

SPECIFICATIONS

- Output Voltage:**
6kV maximum rated continuous operation, 5kV nominal
- Output Current:**
1.2A maximum rated continuous operation, 1.0A nominal

- Output Power:**
5kW for 1+1 redundancy
- Input Voltage:**
-40.5 VDC to -60 VDC
- Programming:**
Full-featured programming, monitoring, alarms, diagnostics, and ramping functions provided via LCU module.
- Monitoring:**
Full local and remote monitoring via Ethernet connection.
- Current Ripple:**
10mA peak to peak of maximum output
- Voltage Ripple:**
0.2% peak to peak of maximum output
- Current Stability:**
0.1% (constant load) after a 4 hour warm up
- Operating Temperature:**
5 to 40°C operating
- Storage Temperature:**
-40 to +85°C storage
- Humidity:**
5% to 85%, non-condensing
- Cooling:**
Forced Air
- Dimensions:**
86.68"H x 23.64"W x 23.64"D
(2200mm x 600mm x 600mm)
- Weight:**
900 pounds (335.9kg)
- Regulatory Approvals:**
Compliant to EEC EMC Directive. Compliant to EEC Low Voltage Directive. X2744 is GR-63-CORE, GR-189-CORE, ETSI ETS 300 019, ETS 300 118, ETS 300 127, ETSI EN 300 132-2, ETSI EN 300 386, EN 60950. UL/CUL recognized file E148969 (A5) (X2743, X2744, X2745).

DIMENSIONS: in.[mm]

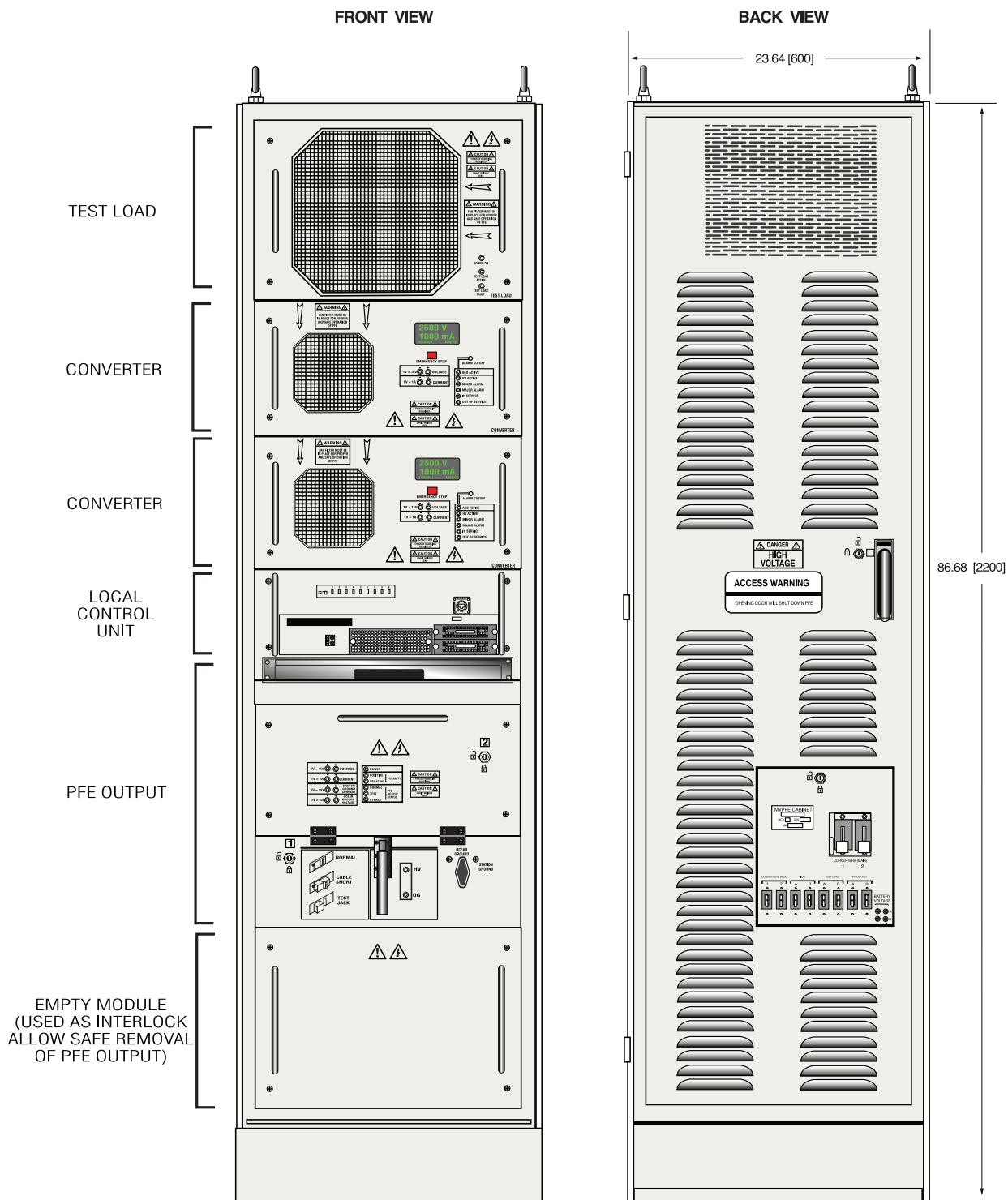



Spellman High Voltage Electronics, the leading independent supplier of Power Feed Equipment to the Telecom industry, has developed a new generation of High Voltage Power Feed Equipment, (HVPFE). This HVPFE is targeted at the emerging requirements for longer submarine cable installations, while addressing underlying issues such as lower cost, smaller foot print, and easier operation.

KEY FEATURES

Redundancy is provided for the converters (n+1)

Simplified sliding drawers for PFE open, grounding, test modes

Redundancy is provided for the LCU. In case of failure of LCU, the PFE will continue to operate normally

LCU contains pull-out 17" LCD screen, keyboard, mouse pad and CPU

Simplified keylock scheme ensures safety of operating personnel

Highly visible Vacuum Fluorescent Display (VFD) on the output module (OMU) and each converter displays voltage, current and modes of operation

Unique protective "trap door" barrier allows a converter to be replaced safely while the PFE is still powering the cable

SPECIFICATIONS

Output Voltage:

18kV maximum rated continuous operation, up to 15kV nominal

Output Current:

1.8A maximum rated continuous operation, 1.5A nominal

- **6, 9, 12, 15kV Versions Available, each @ 1.5A**
- **Full Array of Dry Contact Closures for Remote Station Alarm Monitoring**
- **Fully-Programmable Electronic Test Load Bay Capable of Dissipating 22.5kW**
- **Electroding Functions Provided**
- **3-Bay Design. Rear Doors Provided for Safety Interlocking**
- **Built-in Data Logger Functions Capture Data Every 10ms**

Output Power:

Up to 22.5kW for n+1 redundancy

Input Voltage:

-40.5Vdc to -60Vdc

Programming:

Full-featured programming, monitoring, alarms, diagnostics, and ramping functions provided via LCU module.

Monitoring:

Full local and remote monitoring via Ethernet connection.

Current Ripple:

10mA peak to peak of maximum output

Voltage Ripple:

0.2% peak to peak of maximum output

Current Stability:

0.1% (constant load) after a 4 hour warm up

Operating Temperature:

5 to 40°C operating

Storage Temperature:

-40 to +85°C storage

Humidity:

5% to 85%, non-condensing

Cooling:

Forced Air

Dimensions: (per bay)

86.68"H x 23.64"W x 23.64"D
(2200mm x 600mm x 600mm)

Weight: (per bay)

900 pounds (335.9kg)

Regulatory Approvals:

Compliant to EEC EMC Directive. Compliant to EEC Low Voltage Directive. GR-63-CORE, GR-189-CORE, ETSI ETS 300 019, ETS 300 118, ETS 300 127, ETSI EN 300 132-2, ETSI EN 300 386, EN 60950. Safety IEC 60950-1 E148969- (A5) (X4146, X4147, X4148, X4149, X4750)

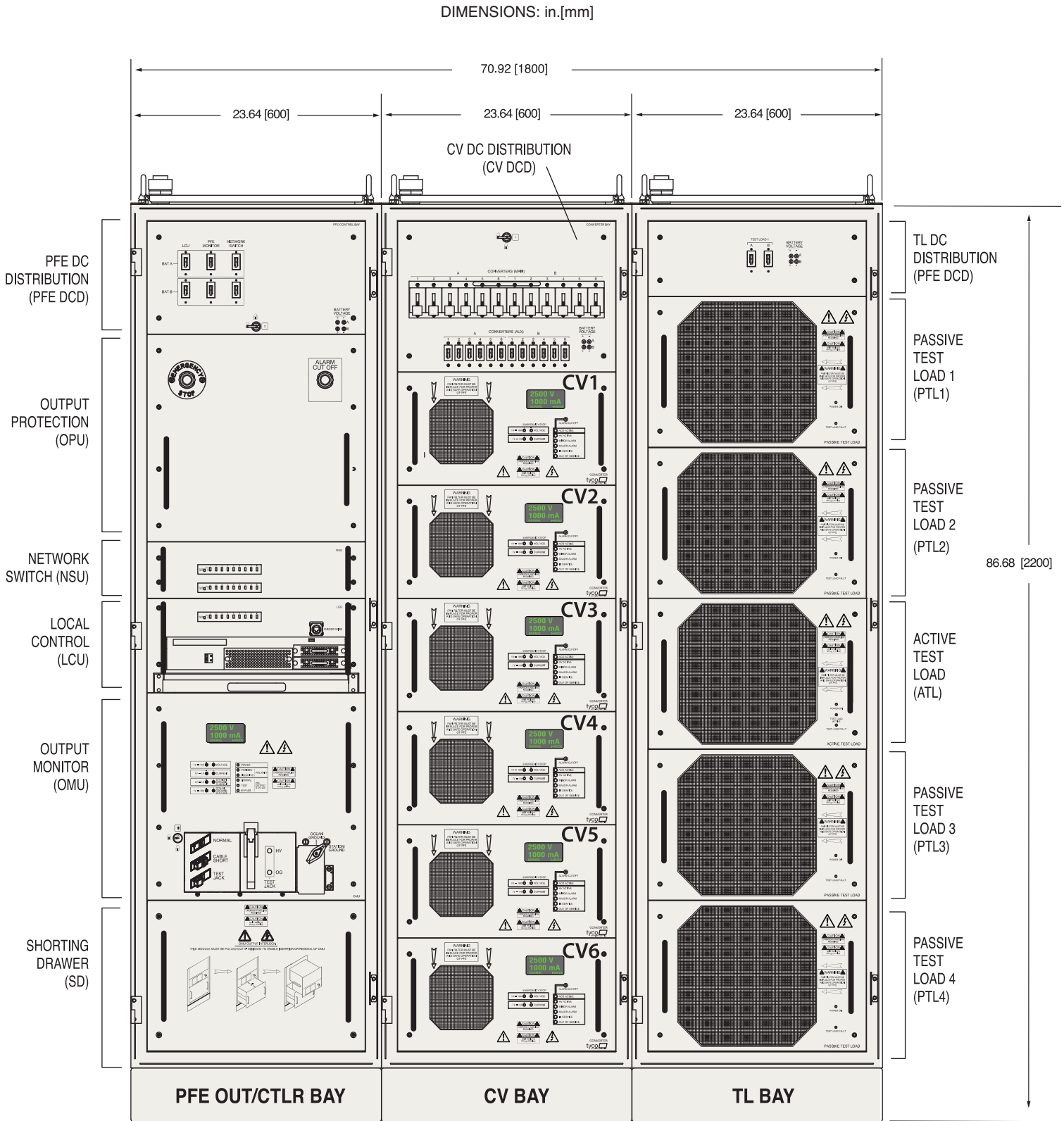



Spellman's new DGM935 high voltage power supply for Image Intensifier applications continues to set the standards for high voltage power conversion technology. The DGM series can be adapted to suit specific requirements with a wide selection of multiple output voltages and power capabilities in a compact package, making it perfect for the OEM user.

Monitoring of all output voltages is possible via local test points. The unit can operate in four modes selectable via three inputs. The output voltages are independently adjustable in each mode by the pre-set potentiometer located on the front of the unit.

TYPICAL APPLICATIONS

- Radiology
- Cardiology
- Neuroradiology
- Night Surveillance
- Non Destructive X-Ray Inspection
- Image Intensifiers

SPECIFICATIONS

Input Voltage:

+24Vdc \pm 1%

Input Current:

500mA maximum

Output Voltages:

Anode:

Output Voltage: 30kV
Output Current: 30 μ A

Electrode 1:

Output Voltage: 50V to 300V
Output Current: 0 to 1 μ A

Electrode 2:

Output Voltage: 300V to 2kV
Output Current: 0 to 1 μ A

Electrode 3:

Output Voltage: 2kV to 18kV
Output Current: 0 to 18 μ A

- **Multiple Outputs**
- **Simple Interface Via Three Control Inputs**
- **Pre set Adjustment of Output Voltages in Four Mode Operation**

Ripple:

<0.3%

Temperature Coefficient:

<200ppmK⁻¹

Stability:

<0.3% over 8 hrs

Temperature:

Operating: +5°C to +55°C

Input:

8 pin header

Dimensions:

6.30"H x 5.51"W x 1.93"D (160mm x 140mm x 49mm)

Weight:

2.86 lb. (1.5kg)

Regulatory Approvals:

Compliant to EEC EMC Directive. Compliant to EEC Low Voltage Directive. Compliant to IEC 60601-1. UL/CUL recognized, File E242588. RoHS Compliant.

INPUT/OUTPUT CONNECTORS

Test Point Terminals:

Wire type suitable for clip on probe.

Output Terminals (0V, OVP and GND):

6.3mm Fast-on connector and M4 x 12mm stud

Output Connector Anode:

M14 X 1 thread, 53mm deep x 8.5mm internal diameter.

Output Connector (electrodes 1 & 2):

5/16 x 32 UNF thread, 26.5mm deep x 5mm internal diameter.

Inputs PC and G:

6.3mm Fast-on connector

Note: 0V, OVP and GND are all connected together internally.

All outputs are protected against high voltage breakdown in the user's equipment and short-circuit protected.

DIMENSIONS: in.[mm]

**TOP VIEW
(A)
Configuration**

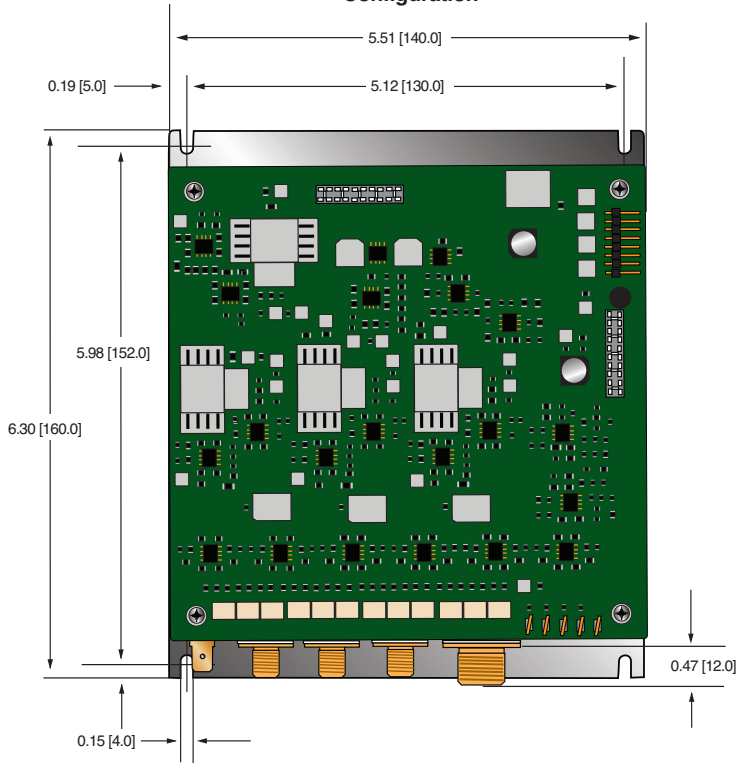

FRONT VIEW

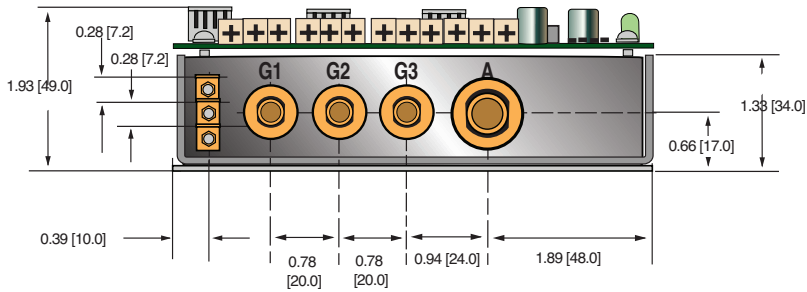

SIDE VIEW

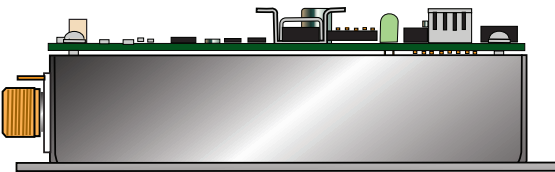

INPUT 8 PIN HEADER

PIN	SIGNAL	SIGNAL PARAMETERS
1	24V	Power Input
2	0V	Power Ground
3	0V	Power Ground
4	24V	Linked internally to pin1
5	M2	Mode select input 2
6	M1	Mode select input 1
7	N/C	N/C
8	M3	Mode select input 3

**ALTERNATE CONFIGURATIONS AVAILABLE
(Specify at time of order)**

**(B)
Configuration**

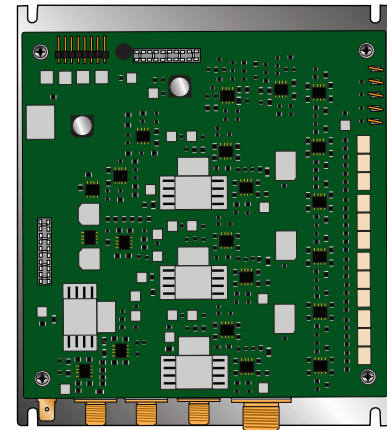

**(C)
Configuration**

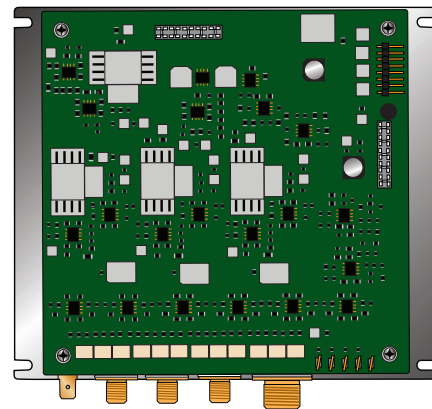



- **Multiple Outputs**
- **Three Control Inputs**
- **Three Optical Encoders**
- **RS-232 Serial Port for Control and Monitoring**
- **OEM Customization Available**

Spellman's new DGM945 high voltage power supply for Image Intensifier applications continues to set the standards for high voltage power conversion technology.

The DGM945 also has inputs to allow measurement of the photocathode current and getter current. The photocathode measurement has two ranges : sensitive range: 0 to 50nA and a standard range: 0 to 15µA. The sensitive input is used to provide a monitor output with a sensitivity of 0.1V/nA. The getter input allows measurement of the getter current, indicating if the Image Intensifier tube is still holding a good vacuum and is without gases causing ions.

Monitoring of all output voltages is possible via local test points or over the serial interface. The unit can also store up to eight modes of operation. The output voltages are independently adjustable in each mode either by the rotary encoders built into the unit or via the serial interface.

The DGM series can be adapted to suit specific requirements with a wide selection of multiple output voltages and power capabilities in a compact package, making it perfect for the OEM user.

TYPICAL APPLICATIONS

- Radiology
- Cardiology
- Neuroradiology
- Night Surveillance
- Non Destructive X-Ray Inspection
- Image Intensifiers

SPECIFICATIONS

Input Voltage:
+24Vdc ±10%

Input Current:
500mA maximum

Programmable Output Voltages:

Anode:
Output Voltage: 30kV
Output Current: 5µA continuous (50µA peak)

Electrode 1:
Output Voltage: 10V to 350V
Output Current: 0 to 10µA

Electrode 2:
Output Voltage: 200V to 2kV
Output Current: 0 to 10µA

Electrode 3:
Output Voltage: 2kV to 20kV
Output Current: 0 to 20µA

Electrode 4:
Output Voltage: 2.7kV
Output Current: 0 to 10µA

Ripple:
<0.3%

Temperature Coefficient:
<200ppmK⁻¹

Stability:
<0.3% over 8 hrs

Temperature:
Operating: +5°C to +55°C

Input Connector:
15 pin male sub D

Dimensions:
5.47"H x 5.67"W x 1.97"D (139mm x 144mm x 50mm)

Weight:
2.86 lb. (1.3kg)

Regulatory Approvals:
Compliant to EEC EMC Directive. Compliant to EEC Low Voltage Directive. Compliant to IEC 60601-1. UL/CUL recognized, File E242588. RoHS Compliant.

INPUT 15 PIN MALE D CONNECTOR

PIN	SIGNAL	SIGNAL PARAMETERS
1	0V	Signal Ground
2	RxD	RS-232 receive data input
3	TxD	RS-232 transmit data output
4	0V	Signal Ground
5	0V	Signal Ground
6	UC2	Mode select input 2
7	0V	Signal Ground
8	OVP	Power return
9	DTR	RS-232 Data terminal ready output
10	CTS	RS-232 Clear to send input
11	N/C	N/C
12	Ipc	Ipc = 10nA / volt
13	UC3	Mode select input 3
14	UC1	Mode select input 1
15	24V	Power input

INPUT/OUTPUT CONNECTORS

Test Point Terminals:

Copper pad plus 1.1 mm Ø pth.

Output Terminals (0V, OVP and GND):

6.3mm Fast-on connector and M4 x 12mm stud

Output Connector Anode:

LGH1

Output Connector (other electrodes):

LGH½

Inputs PC and G:

6.3mm Fast-on connector

Note: 0V, OVP and GND are all connected together internally.

All outputs are protected against high voltage breakdown in the user's equipment and short-circuit protected.

DIMENSIONS: in.[mm]

TOP VIEW

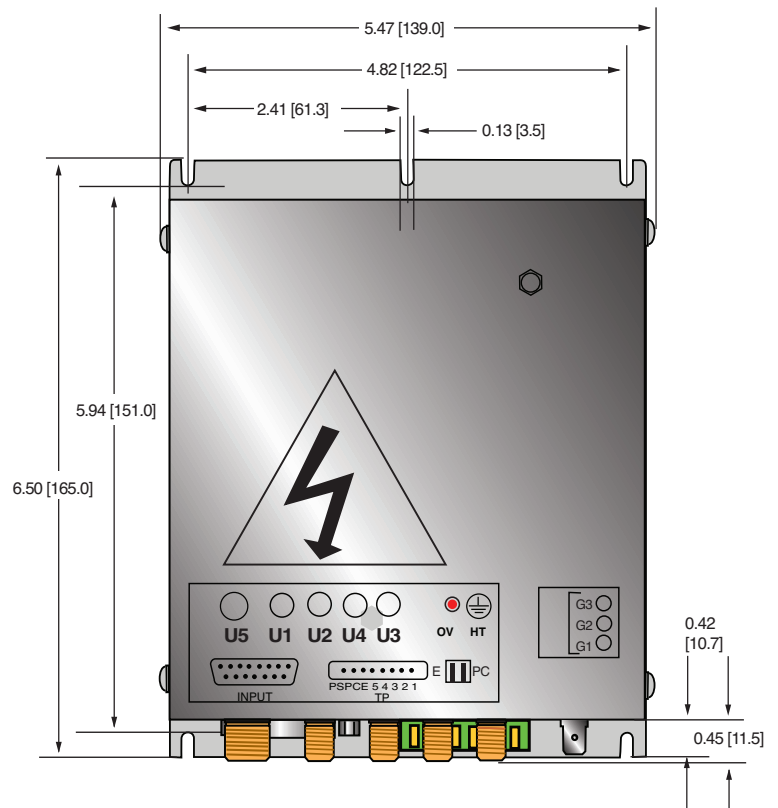

FRONT VIEW

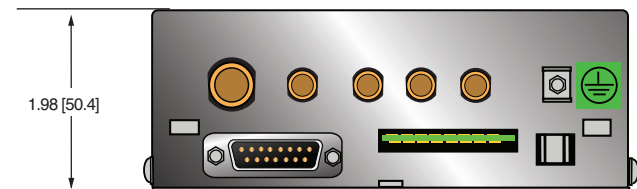

SIDE VIEW

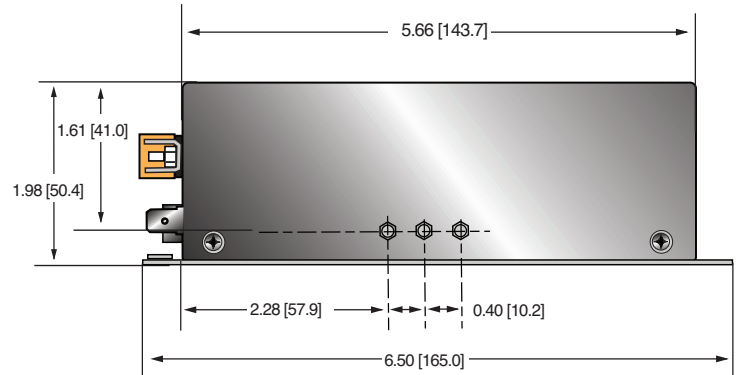



- **Ideal for Electrospinning**
- **0-30kV Local or Remote Programming**
- **0-300 μ A Local or Remote Programming**
- **Polarity Reversible Upon Command in <1 Sec at No Load**
- **Low Stored Energy, Current Limited Output**
- **Full Feature Front Panel, Ideal for Laboratory Usage**

www.spellmanhv.com/manuals/CZE1000R

Spellman's CZE1000R is a full feature rack mountable high voltage power supply ideal for laboratory usage. It's designed to meet the needs of applications requiring a hot switched reversible output voltage. The output polarity can be quickly and safely reversed via a front panel switch.

Both the output voltage and current are fully adjustable from 0 to 30kV and 0 to 300 μ A via front panel ten turn locking counting dials. Remote control operation is done by 0 to +10Vdc programming signals; either user generated or using the provided +10 Vdc reference and external potentiometers.

Front panel voltage and current meters provide local monitoring. Voltage and current test points are provided such that 0 to 10Vdc corresponds to 0 to 100% rated output.

A two position, normally closed, external interlock is provided for protection of external high voltage accessible areas. If the interlock is opened the high voltage will shut off and fall to zero in less than one second and not be able to be re-energized until the interlock is closed.

Excellent load and line regulation specifications along with outstanding stability and low ripple of the CZE1000R assure a stable high voltage output for consistent process results.

TYPICAL APPLICATIONS

Electrospinning
Mass Spectrometry
Capillary Electrophoresis
Electrostatic Research

OPTIONS

220 220Vac Input Voltage
RPO Rear Panel HV Output

SPECIFICATIONS

Input Voltage:

115Vac, $\pm 10\%$, 50/60Hz

Input Current:

Less than 1 amp

Efficiency:

75% typical

Output Voltage:

0 to 30kV

Polarity:

Auto reversible via front panel switch

Output Current:

0 to 300 μ A

Power:

9 watts, maximum

Line Regulation:

0.01% for a 10% input voltage change

Load Regulation:

0.01% for a full load change

Ripple:

0.1% Vp-p

Stability:

0.02% per 8 hours (after 1/2 hr warmup)

NL Time Constant:

100ms

Stored Energy:

0.2 Joules at 30kV

Temperature Coefficient:

100ppm/ $^{\circ}$ C

Operating Temperature:

0 $^{\circ}$ C to 40 $^{\circ}$ C

Storage Temperature:

-40 $^{\circ}$ C to 85 $^{\circ}$ C

Humidity:

10% to 85% RH, non condensing

Cooling:

Convection cooled

Dimensions:

5.25"H x 19"W x 17"D (13.3cm x 48.3cm x 43.2cm).

Weight:

22lbs. (10kg)

Interface Connector:

14 pin terminal block

AC Input Connector:

IEC320 connector with 6' (1.83m) cord

HV Output Connector:

Detachable 36" (0.91m) cable provided

Regulatory Approvals:

Designed to meet EEC EMC Directive. Designed to meet EEC Low Voltage Directive.

CZE1000R TERMINAL BLOCK 14 PIN

PIN	SIGNAL	PARAMETERS
1	+10Vdc Reference Output	+10Vdc, 4mA maximum
2	Internal Voltage Control	Front Panel Program Voltage (programming potentiometer)
3	Voltage Program Input	0 to 10Vdc = 0 to 100% rated output, Z _{in} = 10MΩ
4	Internal Current Control	Front Panel Current Control (programming potentiometer)
5	Current Program Input	0 to 10Vdc = 0 to 100% rated output, Z _{in} = 10MΩ
6	Signal Common	Ground
7	Voltage Test Point	0 to 10Vdc = 0 to 100% rated output, Z _{out} = 10kΩ, 1%
8	Current Test Point	0 to 10Vdc = 0 to 100% Rated Output, Z _{out} = 10kΩ, 1%
9	External Interlock Out	32Vdc @ 2 amps, max, (connect to pin 10 through safety switch)
10	External Interlock In	Return for interlock (connect to pin 9 through safety switch)
11	+10Vdc Reference Output	+10Vdc, 4mA maximum
12	Enable	Open or ground = HV OFF, >3.4Vdc (up to 15Vdc) = HV ON
13	Spare	No Connection
14	Spare	No Connection

Note:

The unit is shipped with the following pins jumpered for front panel operation: 2-3, 4-5, 9-10, 11-12. It is strongly recommended to remove the 9-10 jumper and use a high voltage safety interlock switch.

High Voltage Cable:

A mating high voltage connector is provide with the unit. Have a spare on hand or replace broken/lost mating high voltage cables by ordering Spellman part number 105719-034

DIMENSIONS: in.[mm]

FRONT VIEW

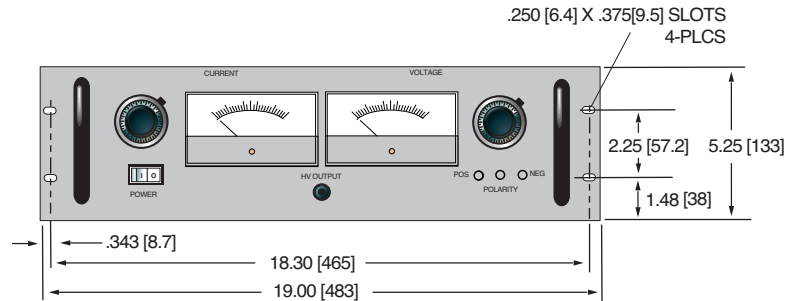

TOP VIEW

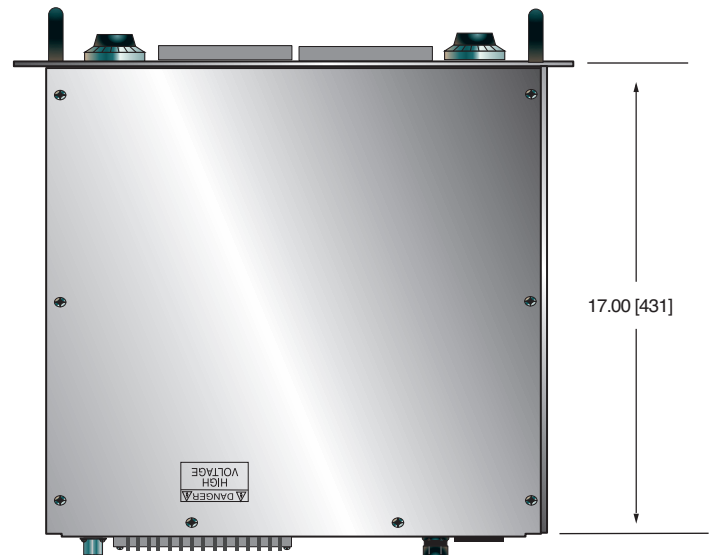

BACK VIEW

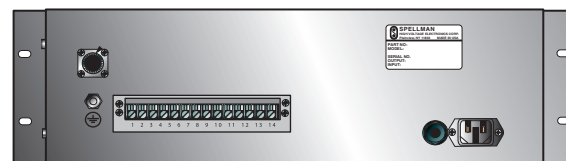



Spellman's CZE2000 modular high voltage power supply is ideal for OEM usage. It is specifically designed to meet the needs of applications requiring a hot switched reversible output voltage. The output polarity of the unit can be quickly and safely reversed via the Polarity Control Signal provided on the interface connector.

Both the output voltage and current are fully adjustable via ground referenced remote programming signals such that 0 to 10Vdc corresponds to 0 to 100% rated output voltage and current.

Remote motioning functionality is provided by voltage and current test points such that 0 to 10Vdc corresponds to 0 to 100% rated voltage and current. Additionally remote polarity and mode indicators provide a comprehensive overview of power supply operation.

Excellent load and line regulation specifications along with outstanding stability and low ripple assure a stable high voltage output for consistent process results.

TYPICAL APPLICATIONS

Electrospinning
Mass Spectrometry
Capillary Electrophoresis
Electrostatic Research

SPECIFICATIONS

Input Voltage:

24Vdc, $\pm 10\%$

Input Current:

Less than 1 amp

Efficiency:

75% typical

Output Voltage:

See selection table

Output Current:

See selection table

Polarity:

Auto reversible via command

Power:

10 watts, maximum

- **Ideal for Electrospinning**
- **0-30kV Remotely Programmable**
- **0-300 μ A Remotely Programmable**
- **Polarity Reversible Upon Command in <1 Sec at No Load**
- **Low Stored Energy, Current Limited Output**
- **Cost Effective Modular Design**

www.spellmanhv.com/manuals/CZE2000

Line Regulation:

0.01% for a 10% input voltage change

Load Regulation:

0.01% for a full load change

Ripple:

0.1% V_{p-p}

Stability:

0.02% per 8 hours (after 1/2 hr warmup)

NL Time Constant:

100ms

Stored Energy:

0.2 Joules at 30kV

Temperature Coefficient:

100ppm/ $^{\circ}$ C

Operating Temperature:

0 $^{\circ}$ C to 40 $^{\circ}$ C

Storage Temperature:

-40 $^{\circ}$ C to 85 $^{\circ}$ C

Humidity:

10% to 85% RH, non condensing

Cooling:

Convection cooled

Dimensions:

3.5"H x 5"W x 10"D (8.9cm x 12.7cm x 25.4cm).

Weight:

6.2lbs. (2.8kg)

Interface Connector:

25 pin male D connector

HV Output Connector:

Detachable 36" (0.91m) cable provided

Regulatory Approvals:

Compliant to EEC EMC Directive. Compliant to EEC Low Voltage Directive. UL/CUL recognized file E148969

CZE2000 SELECTION TABLE

MAXIMUM RATING		MODEL NUMBER
kV	mA	
5	2.0	CZE5PN2000
10	1.0	CZE10PN2000
15	0.67	CZE15PN2000
20	0.50	CZE20PN2000
30	0.30	CZE30PN2000

CZE2000 25 PIN MALE D CONNECTOR

PIN	SIGNAL	PARAMETERS
1	+24Vdc Return	Power Return
2	+24Vdc Return	Power Return
3	+24Vdc Return	Power Return
4	HV Enable/Inhibit	Open or <1Vdc = HV OFF, >3.4Vdc (up to 15Vdc) = HV ON
5	Voltage Test Point	0 to 10Vdc = 0 to 100% rated output, Zout = 10kΩ, 1%
6	Current Test Point	0 to 10Vdc = 0 to 100% rated output, Zout = 10kΩ, 1%
7	Chassis Ground	Ground
8	Remote Voltage Control	0 to 10Vdc = 0 to 100% Rated Output, Zin = 10MΩ
9	Remote Current Control	0 to 10Vdc = 0 to 100% Rated Output, Zin = 10MΩ
10	+10Vdc Reference Output	+10Vdc, 4mA maximum
11	Signal Return	Signal Return
12	Polarity Control	Open or >3.4Vdc (up to 15Vdc) = Positive Polarity. Grounded or <1Vdc = Negative Polarity
13	Positive Polarity Indicator	+24Vdc sourced through a 100Ω series limiting resistor. +24Vdc = active signal
14	+24Vdc Input	Power Input
15	+24Vdc Input	Power Input
16	Chassis Ground	Ground
17	Negative Polarity Indicator	+24Vdc sourced through a 100Ω series limiting resistor. +24Vdc = active signal
18	I Mode Indicator	Open collector pulled up internally to +15Vdc through 2.7kΩ resistor with a 470Ω limiting resistor in series. Transistor OFF = signal active
19	V Mode Indicator	Open collector pulled up internally to +15Vdc through 2.7kΩ resistor with a 470Ω limiting resistor in series. Transistor OFF = signal active
20	Return Current Test Point	0 to 10Vdc = 0 to 100% rated output current, as measured returned from load. Zout = 10kΩ, 1%
21	Load Return	High Voltage Return Point. Required for GFI circuit functionality
22	Ground Fault Indicator	Open collector pulled up internally to +15Vdc through 4.7kΩ resistor with a 470Ω limiting resistor in series. Transistor OFF = signal active
23	Spare	No Connection
24	Spare	No Connection
25	Spare	No Connection

DIMENSIONS: in.[mm]

FRONT VIEW

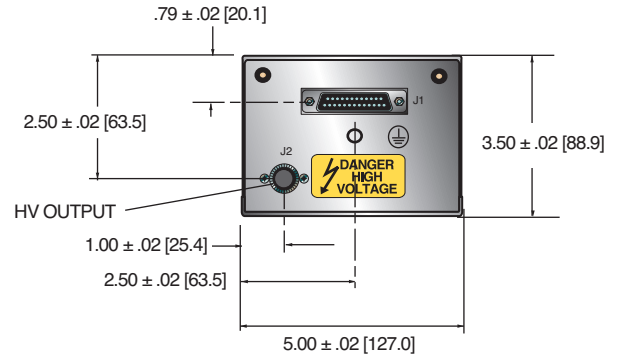

TOP VIEW

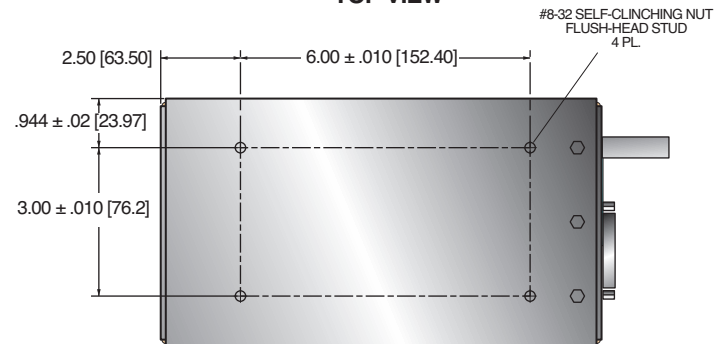

BOTTOM VIEW

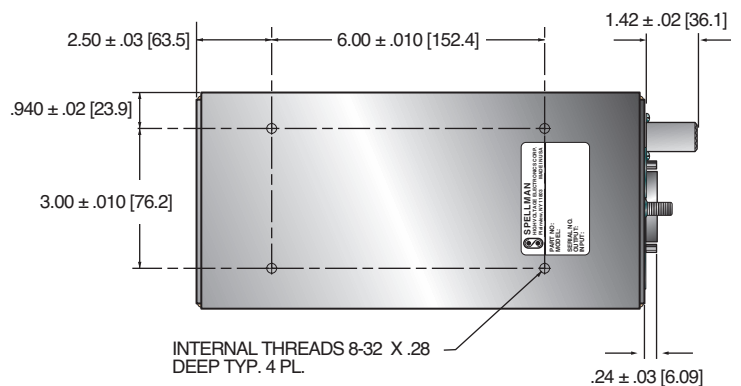



Spellman's CCM1KW capacitor charging module is designed to provide up to 1000 Joules per second at an output voltage up to 4000 Volts. The power factor corrected AC input, small package size and both a comprehensive and minimal analog interface simplifies integrating the CCM1KW into your OEM system design. Available in either positive or negative polarity, the CCM1KW is fully arc, open and short circuit protected. Units can be operated in parallel for applications requiring higher power (see manual for details).

TYPICAL APPLICATIONS

UV light sources for curing and sterilization
Industrial and medical laser applications

SPECIFICATIONS

Input Voltage:

90-264 Vac, 47-63 Hertz, power factor corrected input ≥ 0.98

Input Current:

14 Amps worst case, 1000 Joules per second
7 Amps worst case, 500 Joules per second

Efficiency:

>85%

Output Power:

1000 Joules per second, 500 Joules per second

Output Voltage:

0-1kV, 0-2kV and 0-4kV version available

Output Polarity:

Positive or negative, specify at time of order

Stored Energy:

Less than 0.2 Joules

Pulse to Pulse Repeatability:

$\pm 0.2\%$ up to 1kHz

- **Compact & Lightweight Package**
- **Universal/Power Factor Corrected Input**
- **Low Cost Modular OEM Platform**
- **Advanced Resonant Soft Switching Inverter Topology**
- **RoHS Compliant**
- **UL/CUL Recognized**

www.spellmanhv.com/manuals/CCM1KW

Temperature Coefficient:

≤ 100 ppm per degree C

Fault Diagnostic System:

Over Temperature and Over Voltage
Over Voltage Fault is latched requiring AC power recycle to clear.

Over Temperature Fault is latched but can be cleared via inhibit/fault reset line.

Environmental:

Temperature Range:
Operating: 0°C to 40°C
Storage: -40°C to 85°C

Humidity:
10% to 90% RH, non-condensing

Cooling:

Forced air

Input Line Connector:

2 position Phoenix MSTB connector, straight and right angle mating connector provided

HV Output Connector:

Standard: Kings/Winchester Electronics SHV 1707-1
Optional: Amphenol MHV UG-931/U

Interface-A Connector:

15 pin D, female

Interface-B Connector:

4 pin male Molex 705530038

Ground Stud:

10-32, nut supplied

Dimensions:

3" H X 6" W X 9" D (76.2mm x 152.4mm x 228.6mm)

Mounting:

M4 screw. Max. depth is 0.188" (4.78mm)

Weight:

6.9lb. (3.13kgs)

Regulatory Approvals:

Compliant to 60601-1-1. Compliant to 60601-1-2. UL/CUL recognized file E242584. RoHS compliant.

AC INPUT-2 POSITION TERMINAL BLOCK

PIN	SIGNAL	SIGNAL PARAMETERS
1	AC Input High/Phase 1	Line Hot/Phase 1
2	AC Input Low/Phase 2	Line Neutral/Phase 2

ANALOG INTERFACE A— 15 PIN FEMALE D CONNECTOR

PIN	SIGNAL	SIGNAL PARAMETERS
1	Inhibit/Fault Reset	Ground = HV Enable, Open/+15Vdc = HV Inhibit
2	N/C	N/C
3	OverTemp Fault	No OT Fault = +15Vdc @ 3mA, OT Fault = Ground
4	Signal Ground	Signal Ground (optional)*
5	Voltage Program	0 to 10Vdc = 0 to 100% rated output voltage
6	Overvoltage Status	No OVP = +15Vdc @ 3mA, OVP Fault = Ground
7	Peak Hold Monitor	Peak output voltage displayed, 0 to 10Vdc = 0 to 100% rated output voltage with a 5 second time constant
8	Voltage Monitor	0 to 10Vdc = 0 to 100% rated output voltage, ±1%
9	+15Vdc	+15Vdc @ 150mA, maximum**
10	N/C	N/C
11	+15Vdc	+15Vdc @ 150mA, maximum (optional)**
12	Signal Ground	Signal Ground (optional)*
13	End of Charge	Charging = +15Vdc @ 1.5mA, End of Charge = Ground
14	Signal Ground	Signal Ground
15	Signal Ground	Signal Ground

Note: Output status signals are NMOS transistor controlled, 100mA maximum sink current. Actual signals are 5kΩ pull ups to the internal +15Vdc logic source.

*Optional interface signals can be provided to be compatible with other pre-existing legacy interfaces. On standard units these signals are N/C.

**+15Vdc ±10% is provided on the standard unit. Optional +12Vdc ±5%/100mA, maximum can be provided.

INTERFACE B-4 PIN MALE D HEADER

PIN	SIGNAL	SIGNAL PARAMETERS
1	Inhibit/Fault Reset	Ground = HV Enable, Open/+15Vdc = HV Inhibit
2	Signal Ground	Signal Ground
3	Voltage Program	0 to 10Vdc = 0 to 100% rated output voltage
4	+15Vdc	+15Vdc @ 150mA, maximum (optional)*

CCM1KW SELECTION TABLE

kV	JOULES/SECOND	MODEL
1	500	CCM1*500
2	500	CCM2*500
4	500	CCM4*500
1	1000	CCM1*1000
2	1000	CCM2*1000
4	1000	CCM4*1000

*Specify P for positive or N for negative

500 J/s units have a single internal fan, 1000 J/s units have both an internal and external fan.

TYPICAL GRAPH FOR CCM1P1000

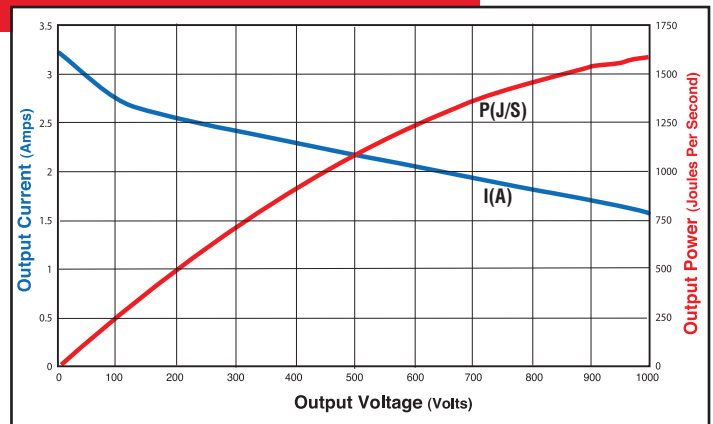

By utilizing a unique inverter topology, a reduction in peak power is achieved for the same average output power



Straight and right angle AC input mating connectors are provided

OPTION ORDERING INFORMATION

OPTION	OPTION CODE
MHV UG-931/U HV Connector	MVH
Legacy Interface Signals	L

OPTION ORDERING EXAMPLE

CCM4P1000/MHV

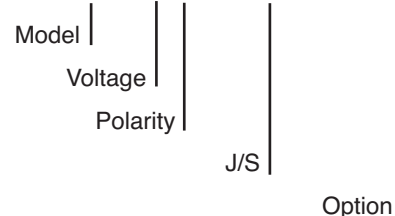

500 Joules per second
(unit with internal fan)
DIMENSIONS: in.[mm]

REAR VIEW

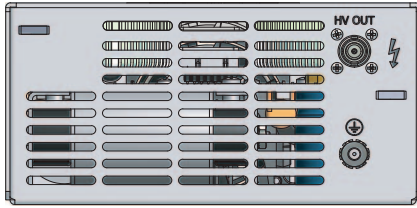

FRONT VIEW

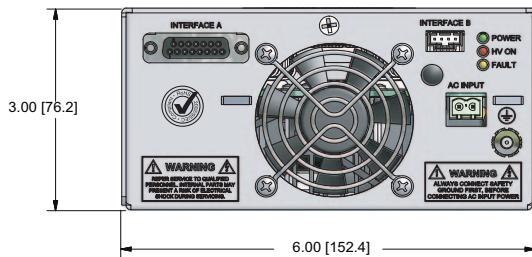

BOTTOM VIEW

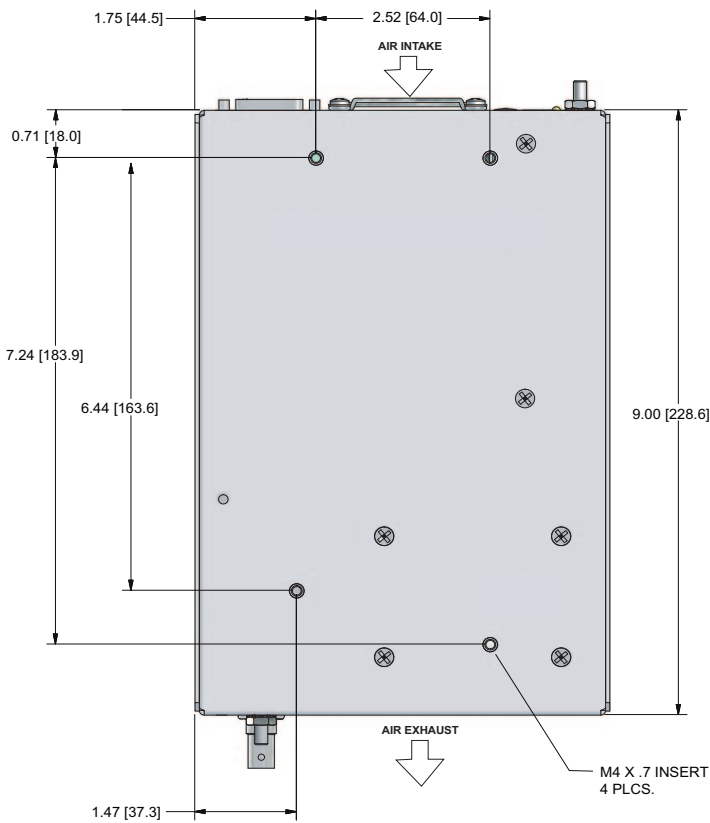

1000 Joules per second
(unit with internal and external fan)
DIMENSIONS: in.[mm]

REAR VIEW

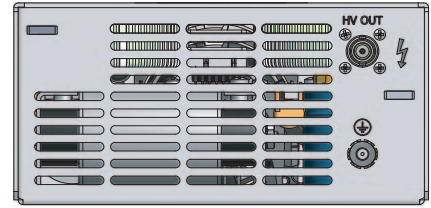

FRONT VIEW

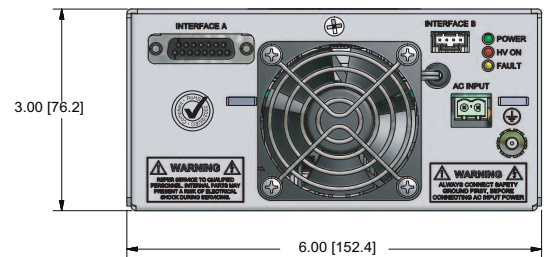

BOTTOM VIEW

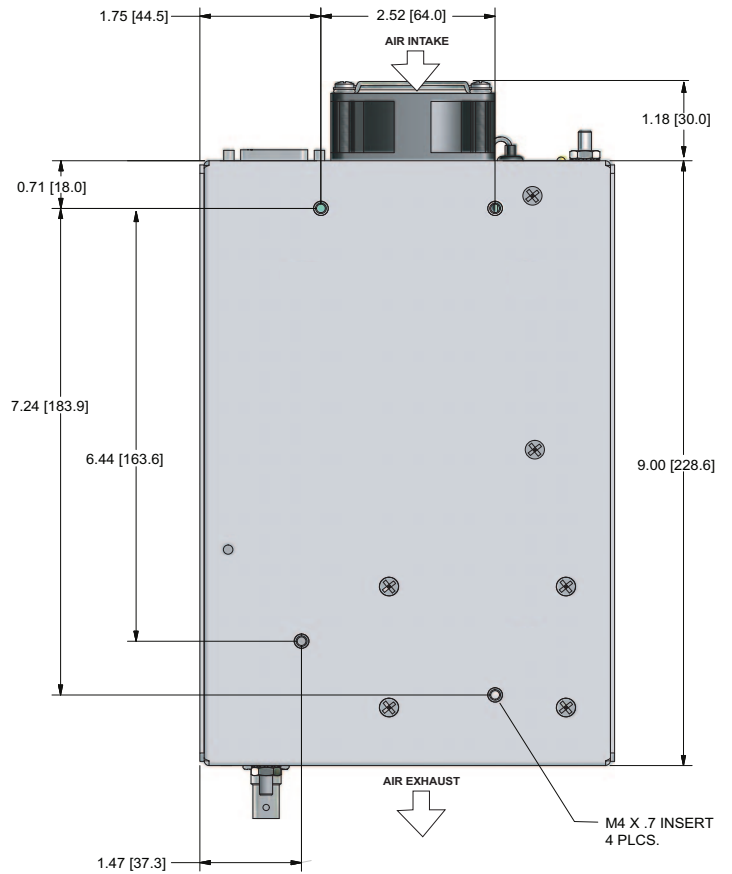



- **Compact & Lightweight Package**
- **Power Factor Corrected Input**
- **Low Cost Modular OEM Platform**
- **Rugged IGBT Inverter Design**
- **Auxiliary +24Vdc @ 2.2 Amp Output Provided**

www.spellmanhv.com/manuals/CCM

Spellman's CCM capacitor charging module is designed to provide 3100 joules per second at an output voltage up to 4000 Volts. With a power density of 6.6 watts per cubic inch, the CCM packs more than 30% more power into the same volume when compared to other commercially available units. The power factor corrected AC input, small package size and comprehensive analog interface simplifies integrating the CCM into your OEM system design. Available in either positive or negative polarity, the CCM is fully arc, open and short circuit protected.

TYPICAL APPLICATIONS

UV light sources for curing and sterilization
Industrial and medical laser applications
ICP-MS applications

SPECIFICATIONS

Input Voltage:

Power factor corrected input ≥ 0.98
180-264Vac @ 20.3A, 47-63Hz, fused via externally accessible fuses

Efficiency:

$>85\%$

Output Power:

3100 Joules per second, average

Output Voltage:

4000 Volts, maximum

Output Polarity:

Positive

Pulse to Pulse Repeatability:

$\pm 0.6\%$ up to 120Hz

Temperature Coefficient:

≤ 100 ppm per degree C

Fault Diagnostic System:

Over Temperature, Over Voltage and Open Load sensing

Environmental:

Temperature Range:
Operating: 0°C to 40°C
Storage: -40°C to 85°C
Humidity:
10% to 90% RH, non-condensing

Cooling:

Forced air

Ground Stud:

M6 X10mm, M6 nut supplied

Input Line Connector:

2 position Phoenix HDFK4 connector

HV Output Connector:

Kings KV-79-15, Bulkhead mounted

+24Vdc Output Connector:

AMP #1-350942-0

Dimensions:

5.81" H X 5.8" W X 14" D (148mm x 147mm x 356mm)

Weight:

14.5lb. (6.6kgs)

Regulatory Approvals:

UL/CUL recognized file E227588

AUXILIARY +24VDC CONNECTOR J2 2 POSITION AMP CONNECTOR

PIN	SIGNAL	SIGNAL PARAMETERS
1	+24Vdc	+24Vdc @ 2.2 amps
2	Ground	Ground

CCM ANALOG INTERFACE— J1 15 PIN FEMALE D CONNECTOR

PIN	SIGNAL	SIGNAL PARAMETERS
1	Inhibit	Ground = HV ON, High = HV OFF
2	Temperature Fault	Fault = OV; no fault = +15Vdc through 6.8kΩ
3	General Fault	Fault = OV; no fault = +15Vdc through 6.8kΩ
4	HV ON Indicator	Ground = HV ON, +15Vdc = HV OFF +15Vdc through 6.8kΩ
5	Voltage Program	0 to 10Vdc = 0 to 100% Rated Output
6	Open Circuit Detector	Fault = OV; no fault = +15Vdc through 6.8kΩ
7	Peak Voltage Monitor	0 to 10Vdc = 0 to 100% Rated Output held for 10 seconds at peak level
8	Voltage Monitor	0 to 10Vdc = 0 to 100% Rated Output, Instantaneous output
9	+15Vdc Output	+15Vdc @ 150ma output, maximum
10	N/C	N/C
11	+15Vdc Output	+15Vdc @ 150ma output, maximum
12	+15Vdc Output	+15Vdc @ 150ma output, maximum
13	End of charge Indicator	Ground = End of Charge, High Impedance = Charging
14	Ground	Ground
15	Ground	Ground

How to Order:

Standard: PART NO.: CCM4P3100

DIMENSIONS: in.[mm]

FRONT VIEW

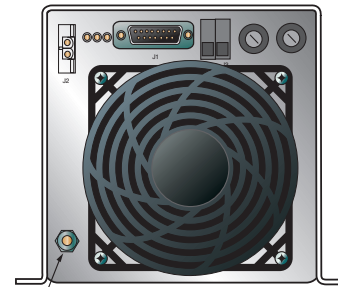

M6 X 10mm STUD
M6 NUT SUPPLIED

TOP VIEW

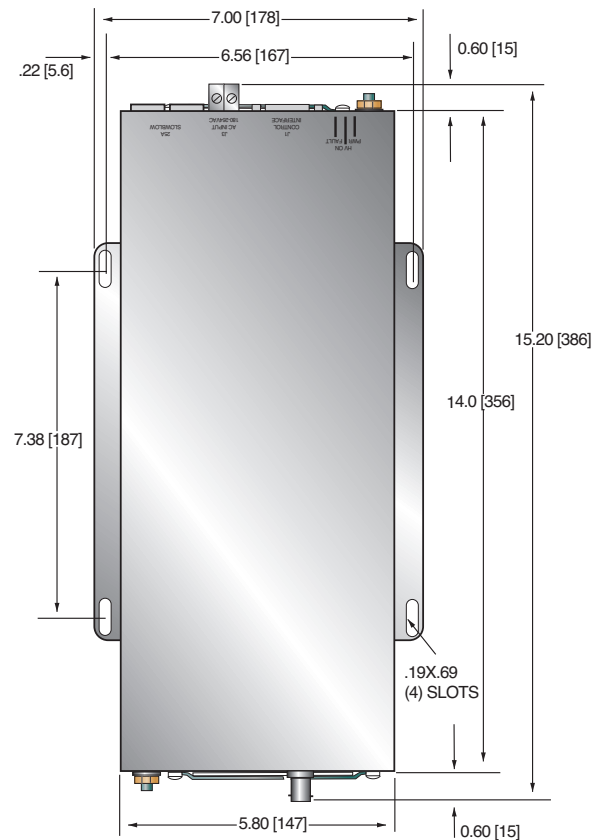

BACK VIEW

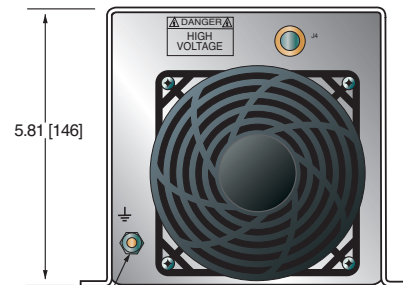

M6 X 10mm STUD
M6 NUT SUPPLIED





12kW 10.50" (6U) Chassis



- **Specially Designed for E Beam Coating Applications**
- **3kW, 6kW and 12kW Power Levels**
- **Remote Analog and Ethernet/RS-232 Interface**
- **Arc and Short Circuit Protected, Fast Arc Recovery**
- **User Configurable Dynamic Arc Intervention**
- **Optional Filament Gun Supply (up to 3 channels)**
- **OEM Customization Available**

www.spellmanhv.com/manuals/EVA

3/6/12KW HV SPECIFICATIONS

Input Voltage: (must be specified at time of order)

- Option 3PH: 180-264Vac, 50/60Hz, three phase, 90% efficiency, 0.85 power factor
- Option 1PH: 180-264Vac 50/60Hz, single phase, 90% efficiency, 0.65 power factor (3kW & 6kW only)
- Option 400VAC: 360-528Vac 50/60Hz, three phase, 90% efficiency, 0.85 power factor (6kW & 12kW only)

Input Current:

- Option 3PH: 180-264Vac, 50/60Hz, three phase
3kW—13 amps, maximum
6kW—25 amps, maximum
12kW—50 amps, maximum
- Option 1PH: 180-264Vac, 50/60Hz, single phase
3kW—29 amps, maximum
6kW—57 amps, maximum
- Option 400VAC: 360-528Vac, 50/60 Hz, three phase,
6kW—13 amps, maximum
12kW—25 amps, maximum

Output Voltage:

- 5kV @ 600mA, negative polarity. 3kW maximum.
- 10kV @ 600mA, negative polarity. 6kW maximum.
- 10kV @ 1200mA, negative polarity. 12kW maximum.

Local Output Controls:

Voltage is continuously adjustable over entire range via a 10 turn potentiometer.

Voltage Regulation:

- Load: 0.05% of full voltage +500mV for full load change.
- Line: 0.05% of full voltage +500mV over specified input range.

Ripple:

<3% Vrms

Stability:

0.02%hr. after 1 hour warm-up.

Temperature Coefficient:

100ppm/°C.

Environmental:

- Temperature Range:
Operating: 0°C to 40°C
Storage: -40°C to 85°C
- Humidity:
10% to 90% RH, non-condensing.

Cooling:

Forced air; inlet through side panels, outlet at rear panel

Metering:

Front panel digital voltage and current meters, 3.5 digit, accurate to within 1%.

Spellman's new EVA Series is specifically designed for demanding electron beam coating applications. A full featured front panel provides local control, while an extensive analog interface allows remote capability. The included Ethernet and RS-232 digital interfaces simplify integrating the EVA into your system design.

The EVA's robust IGBT inverter design is inherently fault tolerant. The proprietary low capacitance, low stored energy high voltage output section is ideal for dynamic load and fault conditions encountered in coating applications. Fast arc recovery times (<2ms) minimize process interruptions. Many operational parameters can be configured by the user to suit their particular requirements via the provided graphical user interface (GUI).

An optional filament gun supply is available. The EVA can support one, two or three filament gun supply channels providing unprecedented flexibility and cost effectiveness.



3kW/6kW 5.25" (3U) Chassis

HARDWARE BASED OPTIONS

- 3PH** 180-264Vac Three Phase Input
- 1PH** 180-264Vac Single Phase Input (3kW & 6kW only)
- 400VAC** 360-528Vac, Three Phase Input (6kW & 12kW only)
- LL(X)** High Voltage Cable Length
- HV2** Two High Voltage Output Connectors
- HV3** Three High Voltage Output Connectors
- FIL1** Filament Gun Supply—One Channel
- FIL2** Filament Gun Supply—Two Channels
- FIL3** Filament Gun Supply—Three Channels
- HPF** 50 Amp Filament Supply

SOFTWARE CONFIGURABLE FEATURES

- Adjustable Overload Trip
- Arc Trip Count
- Arc Quench Time
- Arc Reramp Time
- Arc Window Time

3/6/12KW HV SPECIFICATIONS

System Status Display:

"Dead Front" type indicators provide status of up to 12 system parameters including voltage regulation, fault conditions and circuit control.

Input Power Connector:

A 6 foot (1.8 meter) long captive line cord will be provided.

Analog Interface Connector:

50 pin female D connector

High Voltage Output Cable:

10 ft (3.05m) shielded high voltage cable, removable at rear panel.

Dimensions:

3kW/6kW Units:
5.25"(3U)H x 19" W x 21" D (133mm x 482mm x 533mm)
12kW Units:
10.5"(6U)H x 19" W x 21" D (266mm x 482mm x 533mm)

Weight:

3kW/6kW Units: 46 pounds (20.87kg)
12kW Units: 90 pounds (40.82kg)

Regulatory Approvals:

Compliant to EEC EMC Directive. Compliant to EEC Low Voltage Directive. UL/CUL recognized file E227588. RoHS compliant.

Digital Interface

The EVA features a standard RS-232 and Ethernet digital interface, simplifying power supply communication requirements saving the user time and money, while enhancing functionality and overall capability. Spellman provides a GUI allowing customization of operational features while also providing basic power supply functionality and control via a sample simulated front panel.

Arc Intervention

Spellman's EVA power supplies sense arc events via a fast acting current sense transformer. The arc intervention circuitry prevents power supply damage from continuous, long term arcing. Customers can change arc intervention parameters (Arc Count, Arc Quench, Reramp Time, and Window Time) within preset limits via the provided GUI. Customized units can be configured for unique arc prone environments, contact Spellman for details.

Additional High Voltage Output Connectors

Spellman's EVA is designed to provide 1, 2 or 3 parallel configured high voltage output connectors. The standard unit provides one high voltage output connector. If you intend to use the EVA in a multi channel application but want to utilize your own filament power supply, this factory installed option provides the additional high voltage connections required. Hardware Option HV2 provides two high voltage output connectors, while Hardware Option HV3 provides three high voltage output connectors.

Optional Beam Controller (Filament Power Supply) and Gun Output Box



Beam Controller
1.75" (1U) Chassis

Gun Output Box

Multiple beam control units can be provided, allowing 1, 2 or 3 separate electron guns to be independently operated.

Each beam control unit consists of a beam controller and a gun output box. The beam controller is a 1U rack-mounted chassis containing the filament power, control and emission regulation circuitry. The gun output box contains the high frequency filament transformer which is referenced to the high voltage output potential. This box should be mounted close to the electron gun to minimize the length of the high current filament connections. The box also contains electron gun emission current monitoring circuitry and provides a feedback signal used to regulate the electron gun emission current.

Each beam control channel, if operated alone, can utilize 0 to 100% of the rated emission current capacity. When two or three beam control channels are used at the same time, the total system emission current capacity remains the same. Individual channel programming must be done such that the total current does not exceed the system's total emission current available.

BEAM CONTROLLER SPECIFICATIONS

Input Voltage:

180-264 Vac, 50/60Hz, single phase, 7.5 amps maximum

Output Voltage/Current:

0-12Vrms at \approx 30kHz, 0-35 amps. An optional 50 amp filament (HPF) is available.

Metering:

Front panel digital filament current and emission current meters, 3.5 digit, accurate to within 1%.

System Status Display:

"Dead Front" type indicators provide status of up to 12 system operations including voltage regulation, fault conditions and circuit control.

Input Power Connector:

A 6 foot (1.8 m) long IEC320 Cord Set will be provided.

BEAM CONTROLLER SPECIFICATIONS

Analog Interface Connector:

Male 25 pin D connector

Filament Output Connections: (gun drive cable)

The secondary leads of the filament power transformer exiting the gun output box are 36" (91.44cm) long. The cover of this box is interlocked for safety purposes.

Environmental:

Temperature Range:
 Operating: 0°C to 40°C
 Storage: -40°C to 85°C

Humidity:
 10% to 90% RH, non-condensing.

Cooling:

Forced air; inlet through side panels, outlet at rear panel.

Dimensions:

Beam Controller:
 1.75"H (1U) x 15" W x 19"D (44.5 x 381 X 482.6mm)

Gun Output Box:
 4.06"H x 6.13"W x 11"D (103.2 x 155.7 x 279.4mm)

Weight:

Beam Controller:
 18 pounds (8.1kg)

Gun Output Box:
 6 pounds (2.7kg)

Emission current is programmed locally (front panel adjustment) or remotely (0-10Vdc = 0-100% of rated current) via each beam controller. Filament Limit Set Point, Filament PreHeat Set Point, and Automatic. Filament PreHeat functionality are provided.

EVA MODEL CONFIGURATION

Ordering:

EVA5N3/1PH	3 kilowatt unit, single phase
EVA10N6/3PH	6 kilowatt unit, three phase
EVA10N12/400VAC	12 kilowatt unit, 360-528Vac

Note: Input voltage must be specified at time of order. EVA model number must contain input voltage option code to be valid.

Sample Options:

EVA10N6/1PH/HV2	Single Phase Input & 2 HV Connectors
EVA10N12/400VAC/FIL3	360-528Vac Input & 3 Gun Supplies

TYPICAL EVA OPERATING SETUP

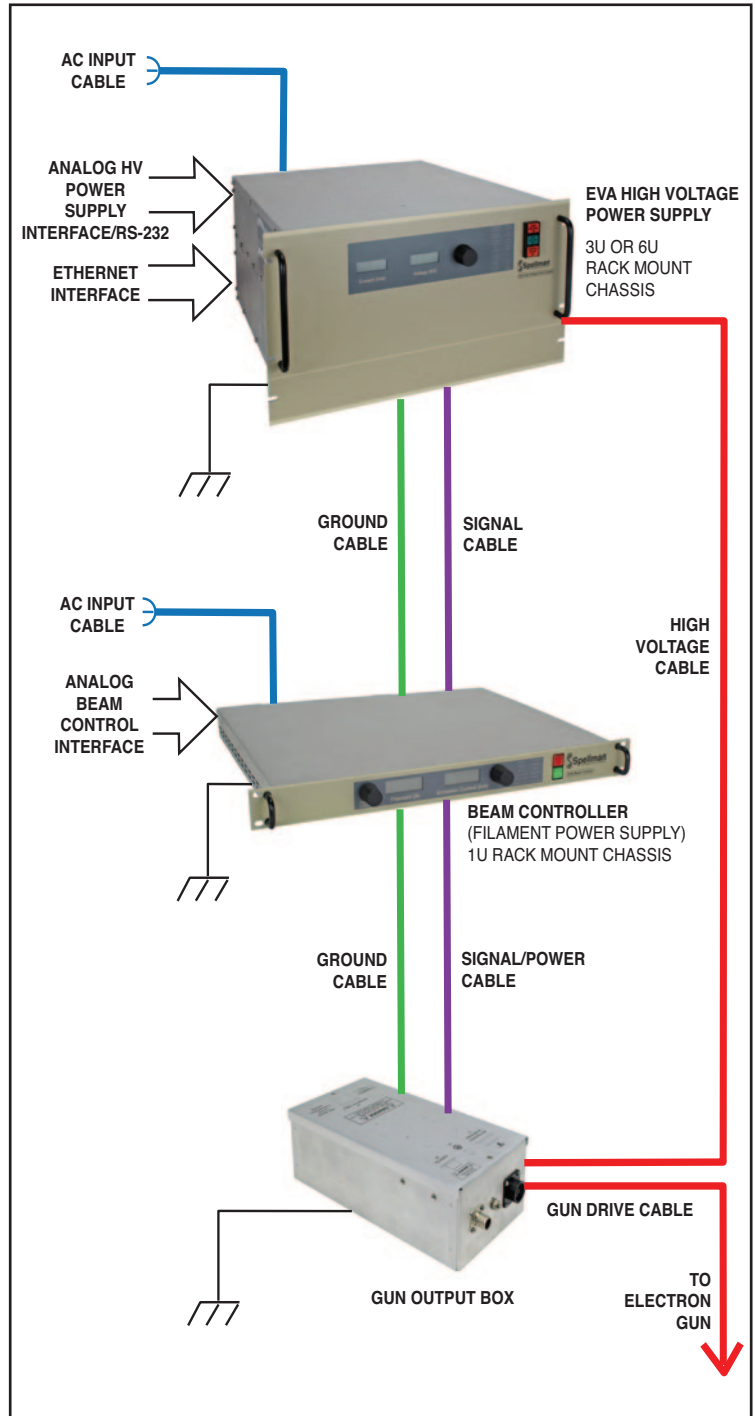

The signal cable connecting the high voltage power supply to the beam controller is 39.4" (1m) long. A captive but field replaceable 10 foot (3.05m) long high voltage cable is provided to connect each beam control output box to the high voltage power supply.

HV POWER SUPPLY INTERFACE— 50 PIN FEMALE D CONNECTOR

PIN	SIGNAL	PARAMETERS
1	Power Supply Common	Power Supply Ground
2	Reset/HV Inhibit	Normally open, Low = Reset/Inhibit
3	External Interlock	+24Vdc @ open, <25mA @ closed
4	External Interlock Return	Return for External Interlock
5	mA Test Point	0-10Vdc = 0-100% rated output, Zout= 1KΩ, 1%
6	kV Test Point	0-10Vdc = 0-100% rated output, Zout= 1KΩ, 1%
7	+10Vdc Reference Output	+10Vdc @ 1mA
8	mA Program Input	0-10Vdc = 0-100% rated output, Zin>10MΩ
9	Local mA Program Output	0-10Vdc = 0-100% rated output, front panel pot
10	kV Program Input	0-10Vdc = 0-100% rated output, Zin>10MΩ
11	Local kV Program Output	0-10Vdc = 0-100% rated output, front panel pot
12	Remote Power On Output	+24Vdc @ open, <25mA @ closed
13	Remote Power On Return	Return for Remote Power On
14	Remote HV Off	+24Vdc @ open, <25mA @ closed, connect to pin15 for front panel operation
15	Remote HV Off/On Common	HV On/Off Common
16	Remote HV On	+24Vdc @ open, <25mA @ closed, momentarily connect to pin 15 enable high voltage
17	HV Off Indicator	+24Vdc @ 25mA = HV Off
18	HV On Indicator	+24Vdc @ 25mA = HV On
19	Power Supply Common	Supply Ground
20	+24Vdc Output	+24Vdc @ 100mA, maximum
21	Voltage Mode Status	Open Collector, Low = Active
22	Current Mode Status	Open Collector, Low = Active
23	Spare	
24	Interlock Closed Status	Open Collector, Low = Active
25	Spare	
26	Spare	
27	Spare	
28	Remote Overvoltage Adjust	0-10Vdc = 0-100% rated output
29	Spare	
30	Over Voltage Fault	Open Collector, Low = Active
31	Over Current Fault	Open Collector, Low = Active
32	System Fault	Open Collector, Low = Active
33	RGLT Error Fault	Open Collector, Low = Active
34	Arc	Open Collector, Low = Active
35	Over Temp Fault	Open Collector, Low = Active
36	AC Fault	Open Collector, Low = Active
37	Spare	
38	Spare	
39	Spare	
40	Spare	
41	Spare	
42	Spare	
43	Spare	
44	+5Vdc Output	+5Vdc @ 100mA, maximum
45	+15Vdc Output	+15Vdc @ 100mA, maximum
46	-15Vdc Output	-15Vdc @ 10mA, maximum
47	RS232 Tx	
48	RS232 Rx	
49	RS232 GND	
50	Power Supply Common	Power Supply Ground

BEAM CONTROLLER INTERFACE— 25 PIN FEMALE D CONNECTOR

PIN	SIGNAL	SIGNAL PARAMETERS
1	Power Supply Common	Signal Ground
2	Spare	
3	External Interlock	+15Vdc at Open, <15mA @ Closed
4	External Interlock Return	Return for Interlock
5	Filament Current Test Point	0 to 10Vdc = 0 to 100% rated output
6	Beam Current Test Point	0 to 10Vdc = 0 to 100% rated output
7	+10Vdc Reference	+10Vdc, 1mA Max
8	Filament Limit Program Input	0 to 10Vdc = 0 to 100% rated output
9	Local Filament Limit Program	Front panel potentiometer wiper
10	Beam Current Program Input	0 to 10Vdc = 0 to 100% rated output
11	Local Beam Current Program	Front panel potentiometer wiper
12	Filament Preheat Program In	0 to 10Vdc = 0 to 100% rated output
13	Local Fil. Preheat Program	Internal potentiometer
14	Beam Off	+15Vdc at Open, <25mA @ Closed
15	Beam On/Off Common	Connect together for FP operation
16	Beam On	Momentarily connect to pin 15 = Beam On
17	Remote Beam Off Indicator	0=Beam On, +15V, 10mA Max=Beam Off
18	Remote Beam On Indicator	0=Beam Off, +15V, 10mA Max=Beam On
19	Spare	
20	Spare	
21	Spare	
22	Remote PS Fault	0 = Fault, +15Vdc @ 0.1mA = No Fault
23	Spare	
24	Power Supply Common	Signal Ground
25	Shield Return	Chassis Ground

DIMENSIONS: in.[mm]

3U 6kW Power Supply

FRONT VIEW

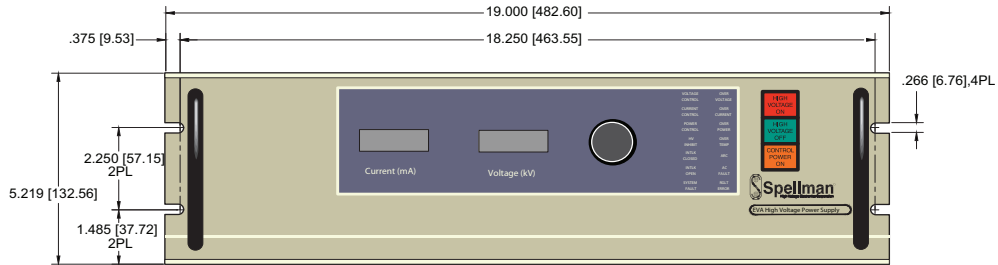

TOP VIEW

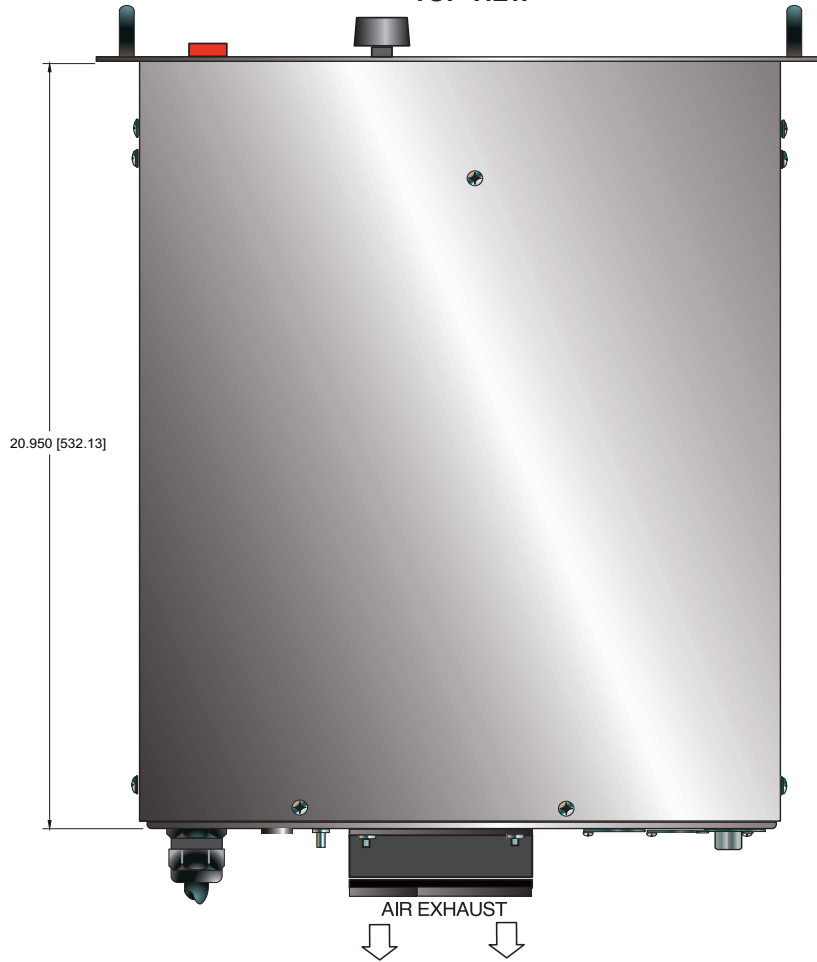

BACK VIEW

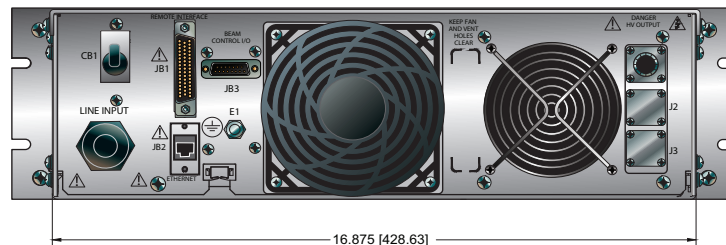

DIMENSIONS: in.[mm]

6U 12kW Power Supply

FRONT VIEW

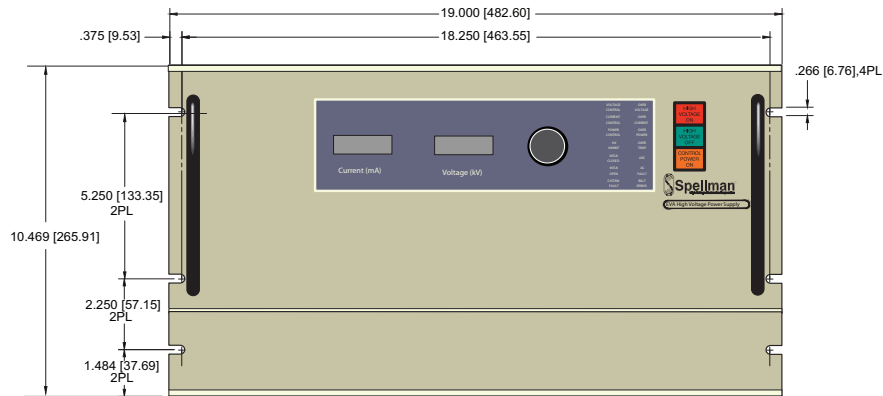

TOP VIEW



BACK VIEW

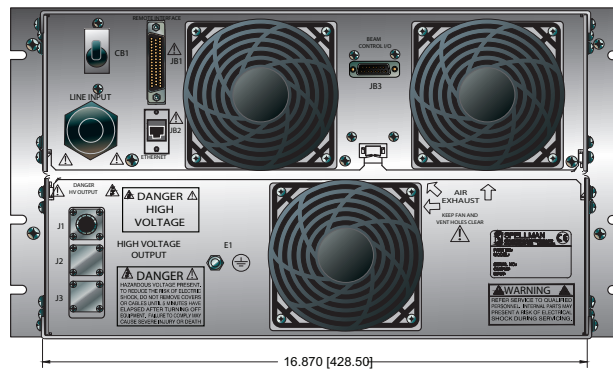



Spellman's ESC Series of electrostatic chuck power supplies provide clean and accurate voltages required for electrostatic chuck wafer processing applications. These custom designed, well regulated supplies precisely secure the wafer during lengthy process cycles. Versions are available with a ground referenced reversible output in addition to units featuring a true floating bipolar output with associated floating center tap point. Comprehensive fault diagnostic circuitry monitors power supply functionality and communicates status data to the user interface. Spellman's ESC Series power supplies are housed in compact, lightweight packages designed for OEM installations requiring minimal system footprint space.

- **Ground Referenced, Reversible Output**
- **Floating, Reversible Bipolar Output**
- **+24Vdc DC Input**
- **Comprehensive Fault Diagnostics**
- **High Voltage Safety Interlock**
- **OEM Customization Available**

Program/Monitor Accuracy:

1% of full scale, $\pm 50\text{mV}$

Dimensions:

9" W x 1.5" H x 6.1" L (228.6mm x 30.5mm x 155mm)

Weight:

4.5lbs. (2kg)

ESC01.5PN7.5

Output Configuration:

Floating, reversible polarity bipolar output with floating center tap

Input:

+24Vdc, $\pm 10\%$ @ 2 amps, maximum

Output:

Bipolar, 0 to $\pm 750\text{Vdc}$ (0 to 1500Vdc total) @ 5mA

Short Circuit Current Limit:

5.5mA, maximum

Output Isolation:

Center tap is isolated for $\pm 2\text{kV}$ from ground

Slew Rate:

40ms, typical

Maximum Cycle Frequency:

10 times per second

Ripple:

2.5Vrms

Line Regulation:

$\pm 0.7\%$ over specified range

Load Regulation:

$\pm 0.7\%$ over specified range

Output Voltage Accuracy:

<1% of set point between 50-1500Vdc

Program/Monitor Accuracy:

0.5% of full scale, $\pm 50\text{mV}$

Dimensions:

3.4" W x 3" H x 10.5" L (86.5mm x 76.5mm x 266.7mm)

Weight:

5lbs. (2.3kg)

TYPICAL SPECIFICATIONS

ESC5PN25

Output Configuration:

Single ground referenced HV output, positive or negative polarity

Input:

+24Vdc, $\pm 5\%$ @ 2 amps, maximum

Output:

+2kV to -5kV. 2mA @ +2kV, 5mA @ -5kV

Short Circuit Current Limit:

5.5mA, maximum

Output Isolation:

None, ground referenced output

Slew Rate:

80ms, typical

Maximum Cycle Frequency:

10 times per second

Overshoot:

<10% of set point value

Ripple:

10Vrms

Line Regulation:

$\pm 0.7\%$ over specified range

Load Regulation:

$\pm 0.7\%$ over specified range

Output Voltage Accuracy:

<2% of set point value between 50-5000Vdc



Spellman's Injector Control Assembly (ICA) multi-output high voltage power supplies are used to supply the appropriate electrode voltages to a triode electron gun in order to inject electrons into a Linear Accelerator (LINAC). The resulting high-energy electron pulses are used to create high-energy X-Rays for applications such as cargo screening and cancer therapy.

This multi-output, rack mount power supply provides the Cathode, Heater and Grid voltages required by the e-gun. The Cathode current can be pulsed up to 500Hz. The Heater and Grid supplies float at the Cathode voltage potential, typically up to -15kV. Injector current is regulated by programming the Grid Pulse Voltage. Remote control and monitoring is via standard Ethernet protocols. LED indicators on the front panel provide basic output and fault status, including Cathode Current and Arc faults.

The ICA series can be customized for specific system requirements.

TYPICAL APPLICATIONS

Cargo screening, cancer therapy

SPECIFICATIONS

Input Voltage:

100-240Vac, 50-60Hz

Cathode:

Output Voltage:

0 to -15kV

Pulsed Cathode Current:

200mA

Mean Cathode Current:

5.5mA (max)

Current Pulse Width:

Up to 6 μ s (90% to 90%)

Current Pulse Frequency:

Up to 500Hz

Current Risetime:

200ns (typical)

Heater:

Output Voltage:

0 to -6.5Vdc (wrt Cathode)

Current:

3A

Resistance:

0.7ohm

- **Multi-Output E-Gun Supply**
- **Fast Rise Time Pulsed Cathode Current**
- **Remote Programming via Ethernet**
- **Customizable for OEM Applications**

Grid (fixed):

Voltage:

-60 to -135Vdc (wrt Cathode)

Current:

250mA

Pulse Voltage:

0 to 340Vdc (wrt Cathode)

Injector Current is regulated by programming the Grid Pulse Voltage

Connections:

Front Panel:

Ethernet (RJ45 jack)

Interlock (24V nominal, 9 pin D-sub male pin plug)

Pulse Input (BNC)

Rear Panel:

AC Power In (IEC320 C14 male pin receptacle)

HV Out (3 pin terminal block)

Interlock:

24V must be present to enable output high voltage cathode. It is intended to connect to the system to disable the ICA in case any system interlocks have not been satisfied.

Operating Temperature:

10°C to +40°C

Storage Temperature:

-40°C to +70°C

Humidity:

30% to 60% relative humidity, non-condensing

Regulatory Approvals:

The ICA is designed to meet 60601-1, and is RoHS compliant.

FRONT PANEL LED INDICATORS

INDICATOR	COLOR	CONDITION Illuminated When...
Trigger Present	Green	Input trigger is present
AC Power	Green	AC supply voltage is present
Interlock In	Green	Interlock in signal is present
Arc Fault	Red	Arc fault signal is active
Cathode Current Fault	Red	Cathode current fault signal is active
Cathode Voltage ON	Amber	Cathode high voltage is present

DIMENSIONS: in.[mm]

FRONT VIEW

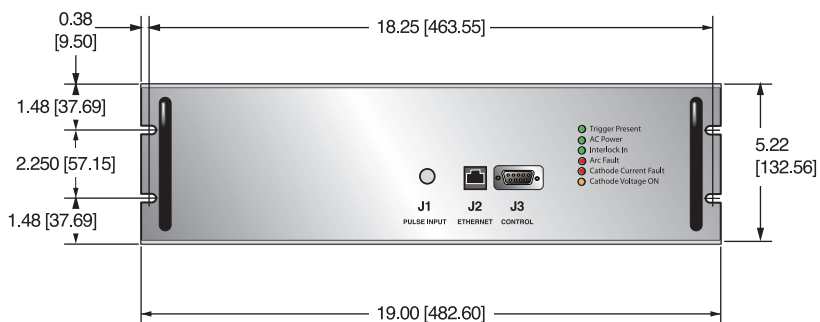

TOP VIEW

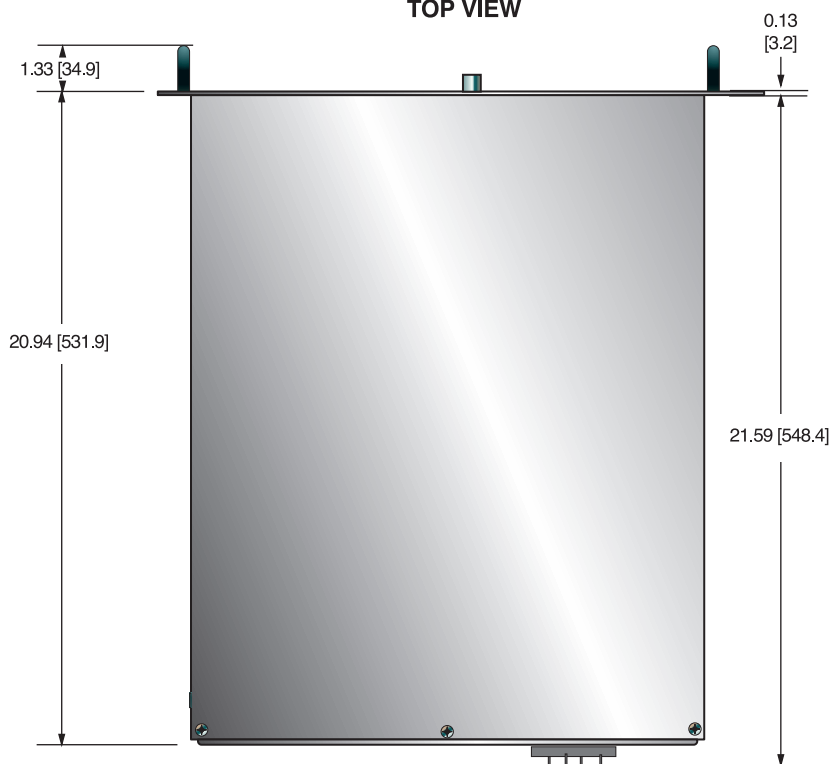

BACK VIEW

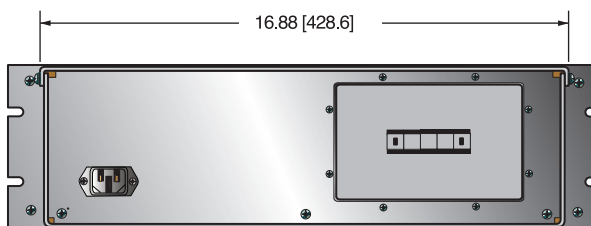



The XRVC Controller (XRVC) provides intuitive, touch screen driven programming and control of any of Spellman's popular XRVC Series of X-Ray generators. This sophisticated and robust controller was designed using an embedded computing system running a custom Graphical User Interface (GUI). The GUI, embedded computer and ancillary hardware are housed in a rugged rack mount or bench top chassis. Capability of the XRVC include: creation of custom X-Ray tube seasoning profiles, one shot or continuous user fabricated operational profiles, automatic X-Ray tube configuration and much more.

SPECIFICATIONS

Input Voltage:

180-264Vac, 50/60Hertz

Dimensions:

Rack mount:

5.25"H x 19"W x 13"D (133.35mm x 482.6mm x 330.2mm)

Bench top:

5.21"H x 17"W x 13"D (132.35mm x 431.8mm x 330.2mm)

Weight:

12 lbs (5.44kg)

Input Power Connector:

14 pin circular connector type 97-3102A-22-19P

Environmental:

Temperature Range:

Operating: 0°C to +50°C

Storage: -20°C to +80°C

Humidity:

0% to 95% RH

Cooling:

Convection cooled

Regulatory Approvals:

Compliant to EEC EMC Directive. Compliant to EEC Low Voltage Directive. RoHS Compliant

ADVANCED CONTROLLER FUNCTIONALITY

Seasoning

- Ability to create, save and load customized seasoning profiles (Default profiles are included)
- Real time seasoning progress, elapsed time and remaining time clocks
- Automatic notice when seasoning is required

- **Intel Atom N270 CPU @ 1.6GHz**
- **1GB Ram**
- **7" Touch Screen LCD @ 800 x 600**
- **Intel 945 Express Graphics**
- **10/100/1000Mbit Ethernet**
- **RS-232 Serial Ports**
- **160GB Internal Hard Drive**

Communications

- Ability to communicate with the XRVC over RS-232 serial port
- Ability to communicate with the XRVC over a direct crossover Ethernet connection or Ethernet switch

One Shot Profiles

- Ability to create, save and load customized one shot profiles
- Verification of profiles within the operating capabilities of the connected XRVC unit

X-Ray Tube Selection

- Specific X-Ray tubes automatically configures the system with the recommended manufactureres operational profiles
- Supported tubes for automatic configuration can be uploaded into the XRVC

Easy to Use

- Intuitive, touch-centric, menu driven system allows operator use with little to no learning curve.
- Communication settings are retained by the XRVC, requiring only a single configuration session.
- Comprehensive status/control screen provides information on all critical operational parameters and system status indicators.

SOFTWARE FEATURES

- Designed for compact, touch centric environment
- Integrated on screen keyboard provides rich input capabilities for operation without an external keyboard
- Adaptive software detects XRVC controller and configures accordingly
- Dynamic feedback allows control of unit with real time viewing of the output

Seasoning Screen

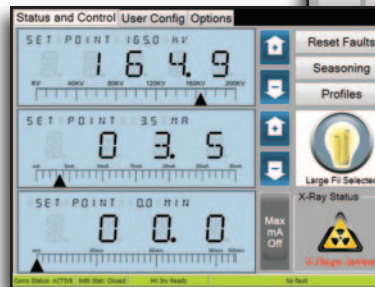
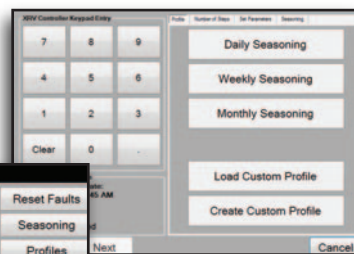

Status and Control Screen



- Mains to Cooler/Chiller, XRV Generator and XRV Touch Screen Controller
- Integrates all Necessary Safety Mechanisms to X-Ray System Environment to Meet International Standards
- X-Ray On, Pre-Warn and Safety Circuit Lamps
- Monitors Tube Cooling and Door Interlocks
- Rack and Wall Mount Versions Available
- Fail Safe Interlock Option Available

Spellman's optional XRV I/O box is the ideal accessory for integrating Spellman's XRV X-Ray generators to a system environment. The XRV can now easily be packaged with industry standard metal ceramic X-Ray tubes, coolers and chillers while meeting all necessary safety and interlock requirements. The XRV I/O box is capable of accommodating a number of control interface options and can be installed in rack or wall configurations to best suit the integrators system placement requirements.

TYPICAL APPLICATIONS

Power distribution for system components

SPECIFICATIONS

Input Voltage:

180-264Vac, 50/60Hz

Operating Temperature:

0°C to +50°C

Storage Temperature:

-20°C to +80°C

Humidity:

0% to 95% relative humidity, non-condensing

Cooling:

Convection

Dimensions:

19.0"W X 5.21"H X 18.00"D

(482.6mm X 132.33mm X 330.2mm)

Weight:

30lbs (11.19kg)

Regulatory Approvals:

Compliant to EEC EMC Directive. Compliant to EEC Low Voltage Directive. RoHS Compliant

TYPICAL SYSTEM SET UP

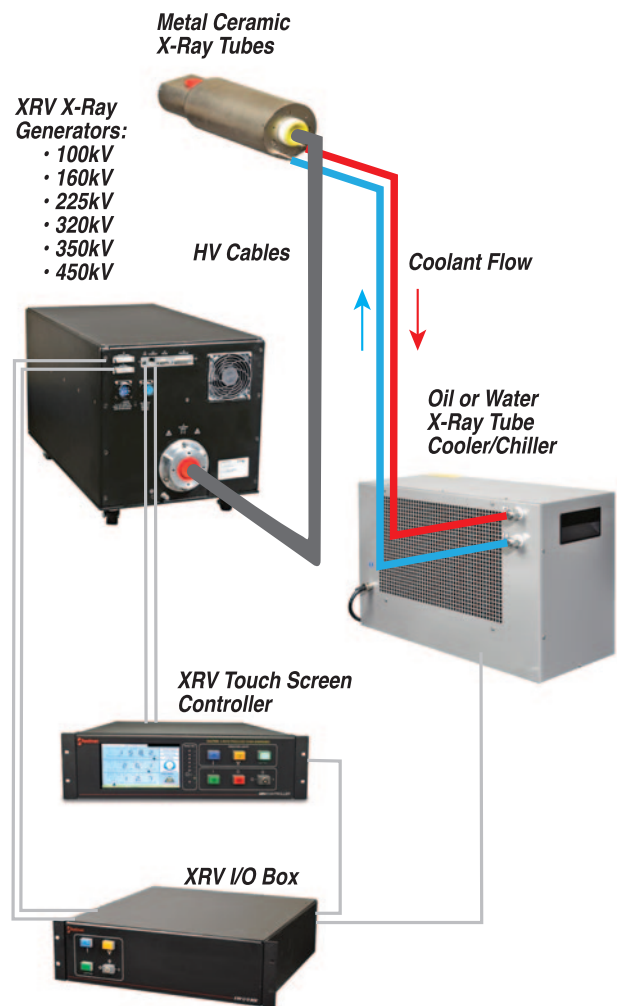

See detailed schematic page 3

XRV I/O BOX SELECTION TABLE

MODEL NUMBER	DESCRIPTION
XRV-9-1	Rack mount without XRV controller
XRV-9-2	Rack mount with XRV controller
XRV-9-3	Wall mount without XRV controller
XRV-9-4	Wall mount with XRV controller
XRV-9-5	Rack mount without XRV controller with optional safety relay for interlocks
XRV-9-6	Rack mount with XRV controller with optional safety relay for interlocks

TB1, TB2, TB3-MAIN AC INPUT POWER—

PIN	SIGNAL	PARAMETERS
TB1-1	Line 1	180 - 264Vac
TB2-1	Line 2	Neutral or 180 - 264Vac (3 phase source)
TB3-1	GND	Ground

TB4- COOLER / CHILLER—MAINS AC OUTPUT

PIN	SIGNAL	PARAMETERS
1	Line 1	180 - 264Vac
2	Line 2	180 - 264Vac or Neutral
3	GND	Ground

TB5-COOLER / CHILLER INTERLOCKS

PIN	SIGNAL	PARAMETERS
1	Flow INTLK	Dry contacts, $\leq 24Vdc$
2	Common	Dry contacts, $\leq 24Vdc$
3	Temp INTLK	Dry contacts, $\leq 24Vdc$

TB6-LOW VOLTAGE / DOOR INTERLOCKS

PIN	SIGNAL	PARAMETERS
1	Door INTLK	Dry contacts, $\leq 24Vdc$
2	Door INTLK	Dry contacts, $\leq 24Vdc$

TB7-XRV I/O MAINS TO CDRH* SAFETY INTERLOCK

PIN	SIGNAL	PARAMETERS
1	Power INTLK Line 1 OUT	180 - 264Vac
2	Line 1 IN	180 - 264Vac
3	Power INTLK Line 2 OUT	Neutral or 180 - 264Vac (3 phase source)
4	Line 2 IN	Neutral or 180 - 264Vac (3 phase source)
5	GND	Ground

*CDRH (Center for Devices and Radiological Health) Safety Interlock Switch meets FDA 21 CFR 1020.40 requirements.

This switch has both low voltage interlock and power interlocks for the XRV mains.

TB8-XRV AUX AC OUTPUT—TO XRV JB1

PIN	SIGNAL	PARAMETERS
A	Line 1	180 - 264Vac
B	Line 2	Neutral or 180 - 264Vac (3 phase source)
C	GND	Ground

TB9-XRV I/O TO XRV CONTROLLER INTERFACE

PIN	SIGNAL	PARAMETERS
1	Line 1	180 - 264Vac
2	Line 2	Neutral or 180 - 264Vac
3	GND	Ground
4	INTLK 1	Dry contacts, $\leq 24Vdc$
5	INTLK 2	Dry contacts, $\leq 24Vd$
6	INTLK Common	Common for INTLK 1, 2
7	X-Ray ON Light	Dry contacts, $\leq 24Vdc$
8	Pre-Warn Light	Dry contacts, $\leq 24Vdc$
9	Light Common	Light common
10	Key Switch 2	Dry contacts, $\leq 24Vdc$
11	Key Switch 3	Dry contacts, $\leq 24Vdc$
12	Key Switch Common	Key common

TB11-X-RAY ON / PRE-WARN LIGHTS

PIN	SIGNAL	PARAMETERS
1	X-Ray ON Light	180 - 264Vac, 5 amp
2	X-Ray ON Light	180 - 264Vac, 5 amp
3	Pre-Warn Light	180 - 264Vac, 5 amp
4	Pre-Warn Light	180 - 264Vac, 5 amp

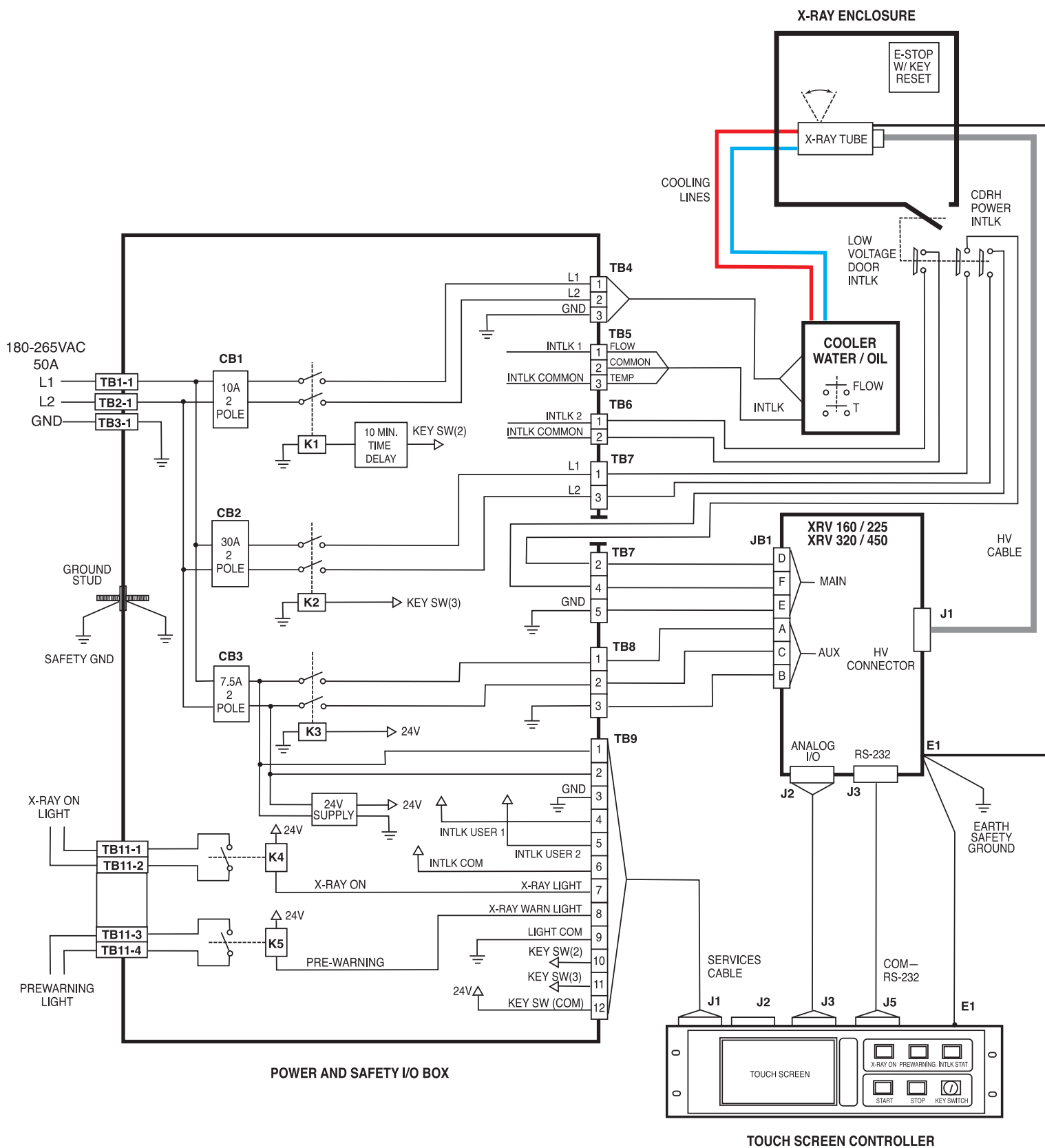

DIMENSIONS: in.[mm]

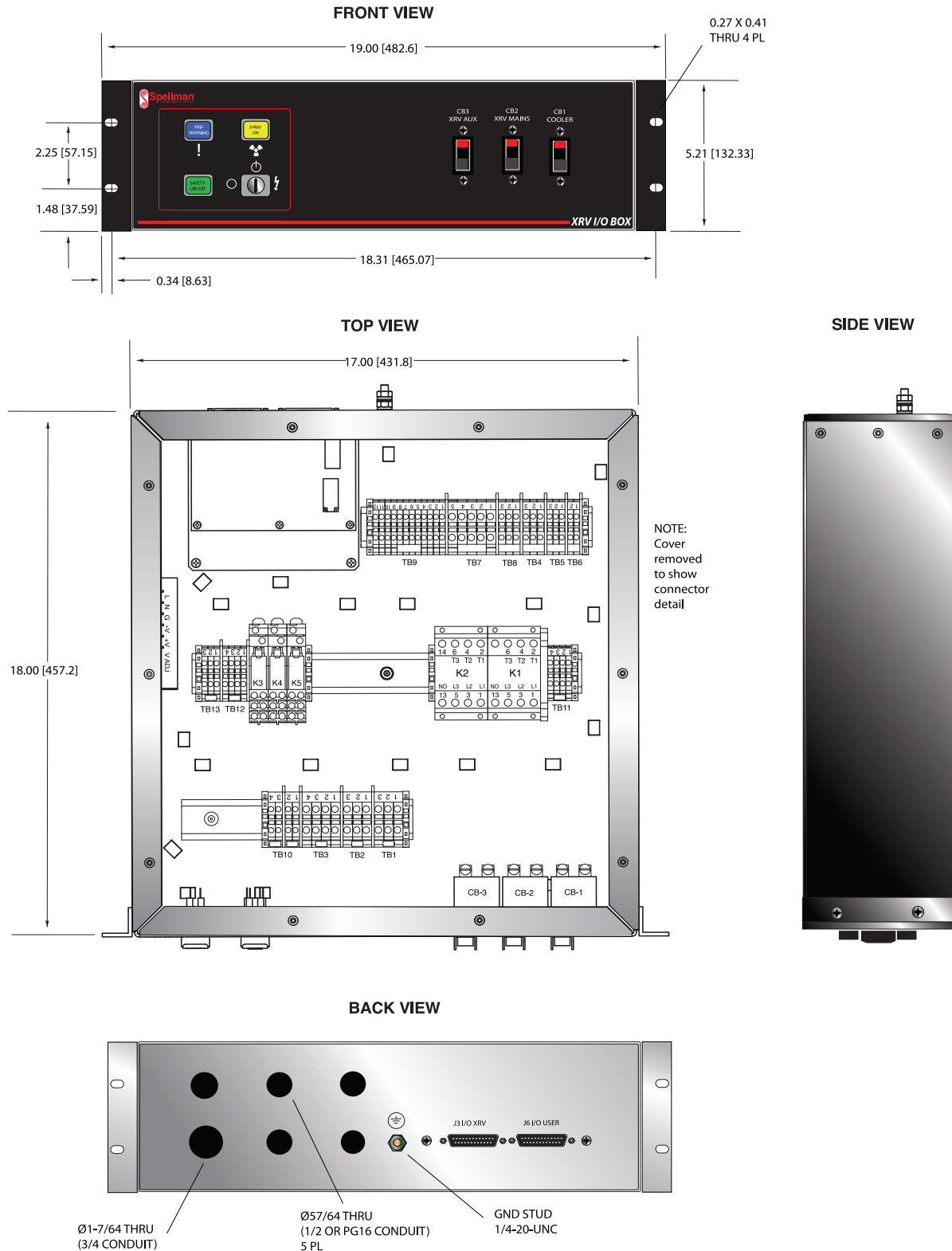

Resistive Voltage Dividers

...for the measurement of high voltages using a standard digital voltmeter*

Spellman's HVD Series of high voltage dividers provide laboratory or production facilities with a convenient method of measuring up to 100kVdc, 200kVdc or 400kVdc with accuracy better than 0.5%. These dividers are designed for use with high impedance digital voltmeters. All HVD dividers are housed in a polycarbonate cylinder containing a matched set of precision metal film resistors which have a temperature coefficient of less than 25ppm. A ladder-type construction technique is used in conjunction with polished high voltage bushings specifically designed to minimize corona. BNC connectors are used to provide the low voltage proportional output signal.

The HVD Series of high voltage dividers have no inferred bandwidth measurement capability what so ever. They are intended for DC steady state measurement only.

Custom Encapsulated OEM High Voltage Dividers

Spellman designs and manufactures a wide array of custom encapsulated high voltage dividers for OEM applications like ion beam implantation for semiconductor manufacturing. Unique HV divider sizes, shapes, mounting arrangements and terminations can be provided addressing specific custom requirements. Contact Spellman to discuss your needs with our knowledgeable sales staff.

Calibration

Spellman provides an NIST traceable calibration certificate with each HVD. A yearly recalibration cycle is recommended. Contact Spellman for calibration services.

- **High Input Impedance**
- **25ppm Temperature Coefficient**
- **100kV, 200kV and 400kV Models**
- **Corona Free Operation**
- **0.5% Accuracy (higher accuracies available)**

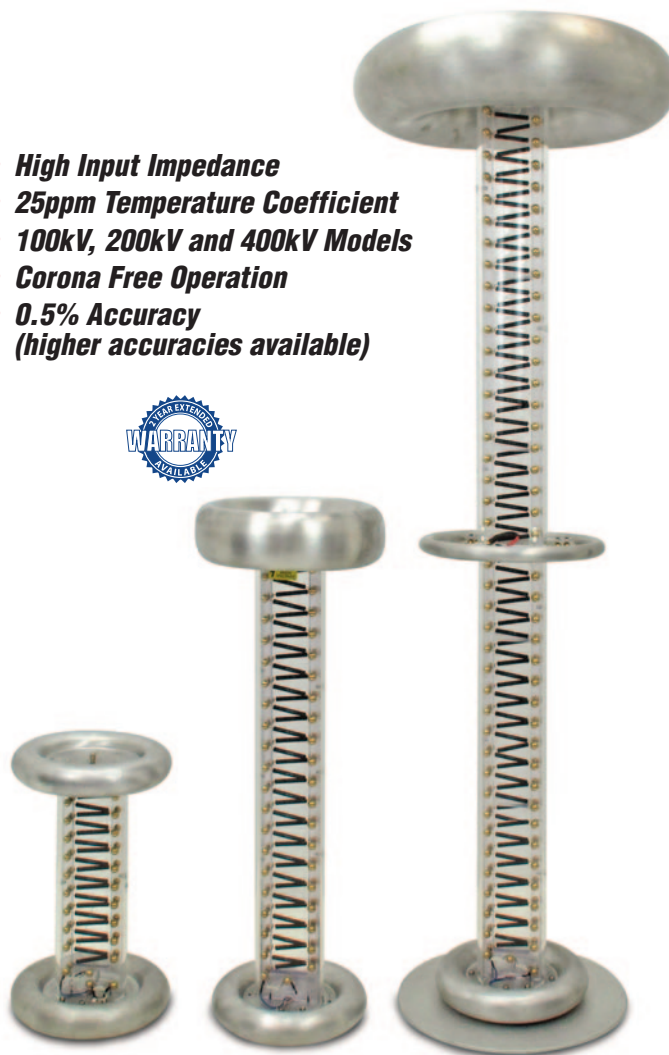

HVD

	HVD100	HVD200	HVD400
Input Voltage	0-100kVdc	0-200kVdc	0-400kVdc
Input Impedance	1000Mohms	2000Mohms	4000Mohms
Output Impedance	1M; 100kohms	20kohms	40kohms
Output Taps	100V, 10V	2V	4V
Accuracy	0.5%: (0.1% opt) ¹	0.5%: (0.25% opt) ²	0.5%
Stability	0.01%/8hrs	0.025%/8hrs	0.025%/8hrs
Temp. Coefficient	25ppm/°C	25ppm/°C	25ppm/°C
Height	17.5" (44.5cm)	33.5" (84.5cm)	61" (154.94cm)
Max. Diameter	10" (25.4cm)	12" (30.5cm)	20" (50.8cm)
Weight	6.75 lbs (3.1kg)	12 lbs (5.5kg)	24.45 lbs (11.8kg)
Output Connector	BNC type	BNC type	BNC type

(1) For accuracy of 0.1% specify HVD100-1
 (2) For accuracy of 0.25% specify HVD200-1

*Impedance of 10Gohm or higher.

WARNING

DANGEROUS LIFE THREATENING VOLTAGES MAY BE PRESENT ON THIS EQUIPMENT. OBSERVE EXTREME CAUTION WHEN OPERATING OR WORKING NEAR HIGH VOLTAGE DEVICES. NEVER TOUCH ANY HIGH VOLTAGE ASSEMBLY THAT IS SUSPECTED TO BE ENERGIZED OR CHARGED. DO NOT HANDLE OR COME WITHIN THE PROXIMITY OF HIGH VOLTAGE CONNECTIONS UNTIL ALL EQUIPMENT IS TURNED OFF AND THE SETUPS CAPACITANCE IS DISCHARGED. FAILURE TO FOLLOW SAFETY PROCEDURES MAY BE FATAL.

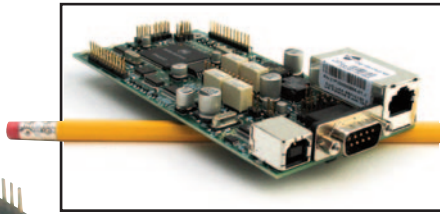

The SIC Option Provides 3 Types of Communications Interfaces:

- **RS-232**
- **Ethernet (10/100-Base-T)**
- **USB—Universal Serial Bus**

Data Acquisition and Control capabilities are Provided by:

- **14 Channels of 12 Bit Analog to Digital Converters**
- **2 Additional Analog Channels that Monitor the Housekeeping Power Supply and Ambient Temperature**
- **5 Digital Output Bits**
- **8 Digital Input Bits**
- **3 Relays/Interlocks**

www.spellmanhv.com/manuals/SIC

HARDWARE FEATURES

The digital hardware includes a 40MIPS digital signal processor, a network processor, and a USB processor/controller. Serial port 0 of the DSP is jumper selectable to allow firmware updating through either the RS-232 port or the Ethernet interface.

RS232 INTERFACE

- 115k bits per second
- No Parity
- 8 Data Bits
- 1 Stop Bit
- No Handshaking
- DB-9 Connector (as shown)

ETHERNET INTERFACE

- 10/100-Base-T
- IP Address can be set by the system integrator
- Network Mask can be set by the system integrator
- TCP Port Number can be set by the system integrator
- RJ-45 connector
- Network attachment via Crossover and standard Ethernet cables
- Supported Operating Systems: Windows 98 2ED, Windows 2000 (SP2), Windows NT (SP6), Windows XP Professional, and most other major operating systems

USB—UNIVERSAL SERIAL BUS INTERFACE

- Compliant with USB 1.1 and USB 2.0 specifications
- Type B male connector
- Included driver can be communicated with via standard Windows serial communications methods

RS-232 CABLING

A standard RS-232 cable where lines 2 and 3 are reversed is used to connect the SIC serial port to the serial port on a standard personal computer

ETHERNET CABLING

Category 5 (CAT5) Ethernet patch cables are used to connect the SIC to the host computer. There are two ways to connect the SIC board via Ethernet: the first is to directly cable between the host and the SIC board, and the second is through the use of a hub, switch or network

USB CABLING

A high-quality double-shielded USB 2.0 Type A or B (host to slave) cable should be used in all applications. This type of cable is a standard PC to peripheral cable that utilizes full size connectors.

High EMI Environments

If the SIC USB interface is being used in a high-EMI environment, ferrites should be added to the USB cable.

SOFTWARE COMPATIBILITY**RS232**

The RS-232 interface makes use of a standard 'command/response' communications protocol. All software that addresses the RS-232 interface must adhere to the following parameters:

- 115k bits per second
- No Parity
- 8 Data Bits
- 1 Stop Bit
- No handshaking

ETHERNET

The SIC board contains an embedded diagnostic web server that can be accessed through any standard web browser by browsing to the SIC's IP address. The Ethernet interface communicates using the following protocols:

- TCP/IP
- HTTP
- Telnet
- FTP

These assemblies can auto-switch between 10 Mb/s and 100Mb/s

USB

The USB interface makes use of a standard 'command/response' communications protocol. The USB interface is accessed through a Windows USB driver that emulates a standard communications port (just like in RS-232). Before you can communicate with the SIC USB interface, you must load the supplied USB driver disc. This driver will create a 'virtual' comm port that can be checked by using Windows Device Manager.

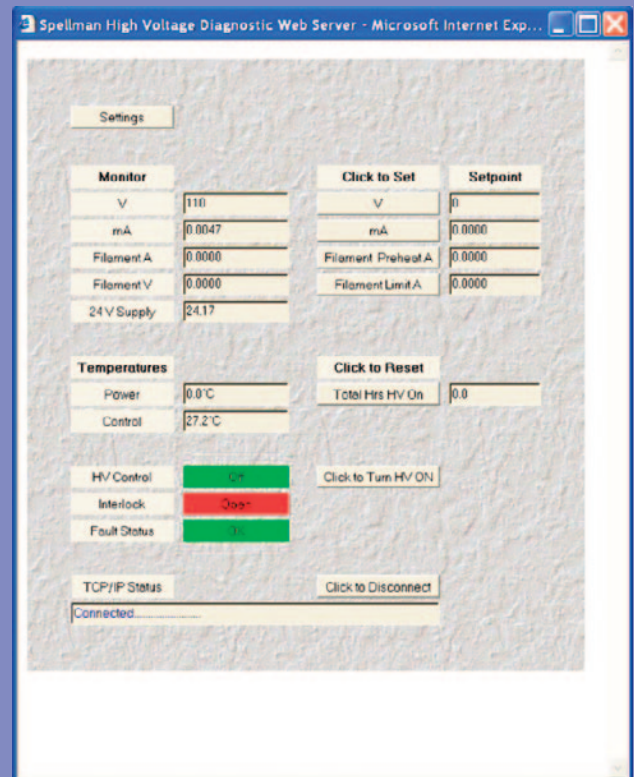
Diagnostic Web Server

The diagnostic web server can control and monitor an SIC equipped power supply from a web browser. It displays operating status of the Power Supply and allows the unit to be configured in real time. The application consists of three web pages; a page displaying contact information, a license agreement, and a monitoring and control applet that is at the heart of this application.

Common High Voltage Power Supply Safety Questions

THE OUTPUT OF ANY HIGH VOLTAGE SUPPLY SHOULD NEVER BE CONSIDERED "SAFE TO TOUCH" UNLESS THE PROPER SERVICING PROCEDURES HAVE BEEN FOLLOWED. REFER TO YOUR OPERATIONS MANUAL FOR INSTRUCTIONS.

Q Can I safely touch the output of one of your high voltage supplies without being hurt?

A Safety is paramount. There is no "safe" level of high voltage that one can touch without risk. Using this guideline, every situation involving high voltage is potentially hazardous. Even with a very low current supply there can be a brief pulse of much higher current due to the discharge of the power supplies output capacitance and high voltage cable capacitance. For proper handling procedures, consult your operations manual.

Q What is safe to touch when working with one of your high voltage power supplies?

A There are parts of the supply that are safe to touch; refer to the instructions of your operations manual. Typically the chassis of the power supply is safe to touch along with all operator controls and most interface connectors. Some other connectors could have line voltage or other potentially hazardous voltages present.

Q How does someone safely use one of your high voltage power supplies?

A To safely use of our high voltage supplies, one needs to comply in all respects with the procedures set forth in the operations manual. In addition, users should comply with the IEEE 510-1983 standard for high voltage practices. The rigorous enforcement of comprehensive and consistent safety practices is the best method of ensuring user safety.

Recommended Safety Reference Material

A copy of excerpts from the IEEE publication Standard 510-1983 "IEEE Recommended Practices for Safety in High Voltage and High Power Testing" is available on Spellman's website at: www.spellmanhv.com/IEEESafety

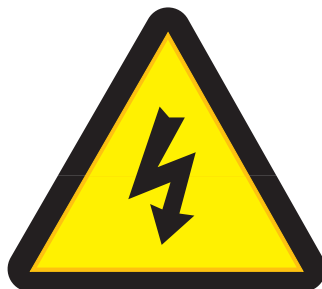

Spellman USA and Corporate HQ

475 Wireless Blvd.
Hauppauge, NY 11788
United States
tel: +1-631-630-3000
fax: +1-631-435-1620
email: sales@spellmanhv.com

Spellman Valhalla NY USA

One Commerce Park
Valhalla, NY 10595
United States
tel: +1-914-686-3600
fax: +1-914-686-5424

Spellman UK

Broomers Hill Park #14, Broomers Hill
Pulborough, West Sussex,
United Kingdom RH20 2RY
tel: +44 (0) 1798 877000
fax: +44 (0) 1798 872479

Spellman Japan

4-3-1 Kamitoda,
Toda-shi, Saitama-ken,
Japan 335-0022
tel: +81 (0) 48-447-6535
fax: +81 (0) 48-445-7280

Spellman China

Spellman High Voltage Electronics (SIP) Co Ltd.
Block D, No.16 SuTong Road,
Suzhou Industrial Park 215021 China
tel: +(86)-512-69006010
fax: +(86)-512-67630030

Spellman High Voltage Korea Co.,Ltd.

#B-720, BRC Smart Valley,
Song Do Mirae-ro 30,
Yeonsu-Gu, Incheon, Korea 406-081
tel: +82-32-719-2300
fax: +82-32-720-4300

Spellman de Mexico – Plant 2

Avenida Pedregal # 2 Esquina
Avenida Chapultepec
Parque Industrial FINSA Oriente
Matamoros, Tamps., Mexico 87340
tel. +52 868 150-1200

Spellman de Mexico – Plant 3

Avenida Chapultepec # 101 Esquina
Avenida Horizonte
Parque Industrial FINSA Oriente
Matamoros, Tamps., Mexico 87340
tel. +52 868 150-1200

Spellman High Voltage GmbH

Josef-Baumann-Straße 23
44805 Bochum
Germany
tel: +49 (0) 234 87906-0
fax: +49 (0) 234 87906-11

